



CATALOGUE TECHNIQUE | V.15 | TECHNICAL CATALOGUE

Meca-inox
BALL VALVES



Notre rôle est de vous accompagner dans vos réussites industrielles. Pour cela, nous travaillons sans cesse sur le renforcement de notre relation, par une approche commerciale de plus en plus dynamique et structurée.

L'amélioration permanente de nos documents contribue à cette démarche.

Cette nouvelle version de notre catalogue est conçue pour faciliter la recherche de produits et accéder plus simplement aux informations techniques par :

- l'intégration des vannes motorisées directement dans les différentes sections,
- la création d'une section spéciale pour les vannes cryogéniques,
- la création d'une section pour les vannes d'application.

Afin de répondre au mieux à ces objectifs, notre catalogue bilingue adopte les améliorations suivantes :

- restructuration du sommaire avec un niveau de recherche plus détaillé,
- version numérique avec liens dynamiques,
- construction adaptée à la déclinaison dans d'autres langues,
- mise à jour des données techniques.

Ce nouveau catalogue est le support technique de notre savoir-faire.

Il évolue chaque année au rythme de notre entreprise.

Je vous souhaite un bon usage,

Our role is to help you achieve industrial success. To do this, we strive to consolidate our relationship by taking an increasingly dynamic and structured approach to what we do.

Constantly improving our documents is part of this approach.

This new version of our catalog is designed to facilitate the search for products and easier access to technical information by:

- *the integration of actuated valves directly in the various sections,*
- *the creation of a special section for cryogenic valves,*
- *la création d'une section pour les vannes d'application.*

To help us fulfil these objectives as effectively as possible, our bilingual catalogue has embraced the following improvements:

- *restructuring the contents, with a more detailed level of research,*
- *numeric version with dynamic links,*
- *structure suited to versions in other languages,*
- *updates to the technical data.*

This new catalogue provides technical backup for our expertise.

It changes each year as our company evolves.

I hope you find it useful,

Hugues Beurel
PDG / CEO

Sommaire | Summary

Vanne 3-pièces			I - 01	3-piece ball valve		
Avantages	I - 02	Features				
Étanchéités	I - 04	Seals				
Nomenclatures	I - 07	Components				
Types de joints	I - 09	Seats & seals material				
Calcul KV - Codifications	I - 13	KV Values - Codification				
Raccordement à souder en bout	I - 14	Butt weld valve				
Raccordement à souder emboité	I - 16	Socket weld valve				
Raccordement taraudé	I - 18	Thread valve				
Raccordement double bagues	I - 20	Compression fittings valve				
Raccordement à clamp	I - 21	Triclamp ends valve				
Raccordement à soudure orbitale	I - 22	Orbital welding valve				
Autres normes de tube	I - 23	Other pipe standards				
Raccordement à brides	I - 24	Flanged valve				
Vanne 3 voies	I - 26	3-way valve				
Nomenclature PS4 motorisée DN 08 à 50	I - 28	PS4 actuated components size 1/4" to 2"				
Dimensionnement PS4 - DN 08 à 50	I - 29	PS4 sizing - 1/4" to 2"				
Dimensionnement PZ4 - DN 08 à 50	I - 30	PZ4 sizing - 1/4" to 2"				
Dimensionnement PY4 - DN 08 à 50	I - 31	PY4 sizing - 1/4" to 2"				
Nomenclature PS4 motorisé DN 65 à 150	I - 32	PS4 actuated components size 2"1/2 to 6"				
Dimensionnement PS4 - DN 65 à 150	I - 33	PS4 sizing - 2"1/2 to 6"				
Dimensionnement PZ4 - DN 65 à 150	I - 34	PZ4 sizing - 2"1/2 to 6"				
Dimensionnement PY4 - DN 65 à 100	I - 35	PY4 sizing - 2"1/2 to 4"				
Vanne Cryogénie			II - 01	Cryogenic valve		
Types de joints	II - 02	Seats & seals material				
Nomenclatures	II - 03	Components				
Dimensions	II - 07	Size				
Vanne cryogénie 3 voies	II - 08	3-way cryogenic valve				
Vanne mixte bronze / inox	II - 10	Combined valve: bronze / Stainless steel				
Dimensionnement PY4 CY - DN 08 à 50	II - 11	PY4 CY sizing - 1/4" to 2"				
Dimensionnement PY4 CY - DN 65 à 100	II - 13	PY4 CY sizing - 2"1/2 to 4"				
Vanne 2-pièces			III - 01	2-piece ball valve		
Avantages	III - 02	Features				
Étanchéités	III - 03	Seals				
Codifications	III - 05	Codification				
Nomenclatures	III - 06	Components				
Types de joints	III - 09	Seats & seals material				
Vanne DIN court	III - 11	DIN valve short pattern				
Vanne DIN long	III - 13	DIN valve long pattern				
Nomenclature R2 motorisé DN 15 à 50	III - 14	R2 actuated components size 1/2" to 2"				
Dimensionnement R2S/R2H - DN15 à 50	III - 15	R2S/R2H sizing - 1/2" to 2"				
Dimensionnement R2Z - DN15 à 50	III - 16	R2Z sizing - 1/2" to 2"				
Nomenclature R2 motorisé DN 65 à 200	III - 17	R2 actuated components size 2"1/2 to 8"				
Dimensionnement R2S/R2H - DN 65 à 200	III - 18	R2S/R2H sizing - 2"1/2 to 8"				
Dimensionnement R2Z - DN 65 à 150	III - 19	R2Z sizing - 2"1/2 to 6"				
Vanne d'application			IV - 01	Application ball valve		
Vanne fluide propre	IV - 02	Clean fluid valve				
Vanne usiné	IV - 03	Machined valve				
Vanne V-ball	IV - 04	V-ball valve				
Vanne fond de cuve	IV - 05	Tank bottom valve				
Vanne affleurante	IV - 06	Flush valve				
Vanne prise échantillon	IV - 08	Sampling ball valve				

Sommaire | Summary

Vanne d'application			Application ball valve			
Vanne isolement & purge	IV - 09	Double block and bleed				
Vanne enveloppe thermique	IV - 10	Steam jacketed valve				
Clapet	IV - 11	Check valve				
Viseur	IV - 12	Sight glass				
Filtre	IV - 13	Filter				
Vanne économique 3-pièces	IV - 14	3-piece economic valve				
Vanne monobloc	IV - 15	1-piece ball valve				
Motorisation Accessoires			V - 01	Actuation Accessories		
Motorisation pneumatique			Pneumatic actuation			
Presentation	V - 02	Presentation				
Avantages	V - 04	Features				
Actionneur Cni	V - 06	Cni actuator				
Caractéristiques de fonctionnement	V - 07	Operating details				
Couples de manœuvre	V - 08	Operating torques				
Nomenclatures Types "S"	V - 10	"S" type components				
Dimensions type "S"	V - 11	Overall dimensions "S" type				
Nomenclatures Types "C" & "E"	V - 12	"C" & "E" type components				
Dimensions type "E"	V - 13	Overall dimensions "E" type				
Dimensions type "C"	V - 14	Overall dimensions "C" type				
Motorisation électrique			Electric actuation			
Présentation modèle "EZ"	V - 15	EZ type presentation				
Caractéristiques de fonctionnement	V - 16	Basic operating details				
Dimensions type "EZ"	V - 17	Overall dimensions "EZ" type				
Accessoires			Accessories			
Zone saine			Safe area			
Boîtier fin de course	V - 20	Limit switch box				
Electrodistributeur	V - 21	Solenoid valve				
Bloc détecteur	V - 22	Inductive sensors				
Zone ATEX			ATEX area			
Boîtier fin de course Eex "ia"	V - 23	Eex "ia" limit switch box				
Electrodistributeur Eex "ia"	V - 24	Eex "ia" Solenoid valve				
Bloc détecteur Eex "ia"	V - 25	Eex "ia" Inductive sensors				
Boîtier fin de course Eex "ed"	V - 26	Eex "ed" limit switch box				
Electrodistributeur Eex "em"	V - 27	Eex "em" Solenoid valve				
Electrodistributeur Eex "d"	V - 28	Eex "d" Solenoid valve				
Autres solutions de boîtier fin de course	V - 29	Limit switch box other solutions				
Options Maintenance			VI - 01	Options Maintenance		
Options de manœuvre			Options for operation			
Rehausse	VI - 02	Stem extension				
Levier inox cadénassable	VI - 04	Stainless steel handle				
Levier rehaussé DN08-50	VI - 05	Extended handle size 1/4" - 2"				
Volant	VI - 06	Handwheel				
Levier rehaussé DN65-150	VI - 07	Extended handle size 2"1/2" - 6"				
Sécurité en retour de position	VI - 08	Operation safety				
Solution d'arrêt en urgence	VI - 09	Emergency shut-off valve				
Manœuvre de secours des robinets motorisés	VI - 09	Emergency operation of the actuated valve				
Maintenance			Maintenance			
Pièces de rechange robinet 3-pièces	VI - 12	Spares for 3-piece valve				
Pièces de rechange robinet 2-pièces	VI - 13	Spares for 2-piece valve				
Pièces de rechange clapet, visuer & filtre	VI - 14	Spares for check valve, sight glass & filter				
Pièces de rechange actionneur pneumatique	VI - 14	Spares for pneumatic actuators				

DN 08 à 200

PN 100 / PN 16
Passage Standard ou intégral
Brides tournantes
Platine ISO



Série en acier inoxydable
Stainless steel series

Size 1/4" to 8"

PN 100 / PN 16
Reduced or full bore
Rotating ends system
ISO top flange



Série en acier carbone
Carbon steel series



Série DN 65 à 200
Size 2"1/2 to 8" series



Série Motorisée
Actuated series

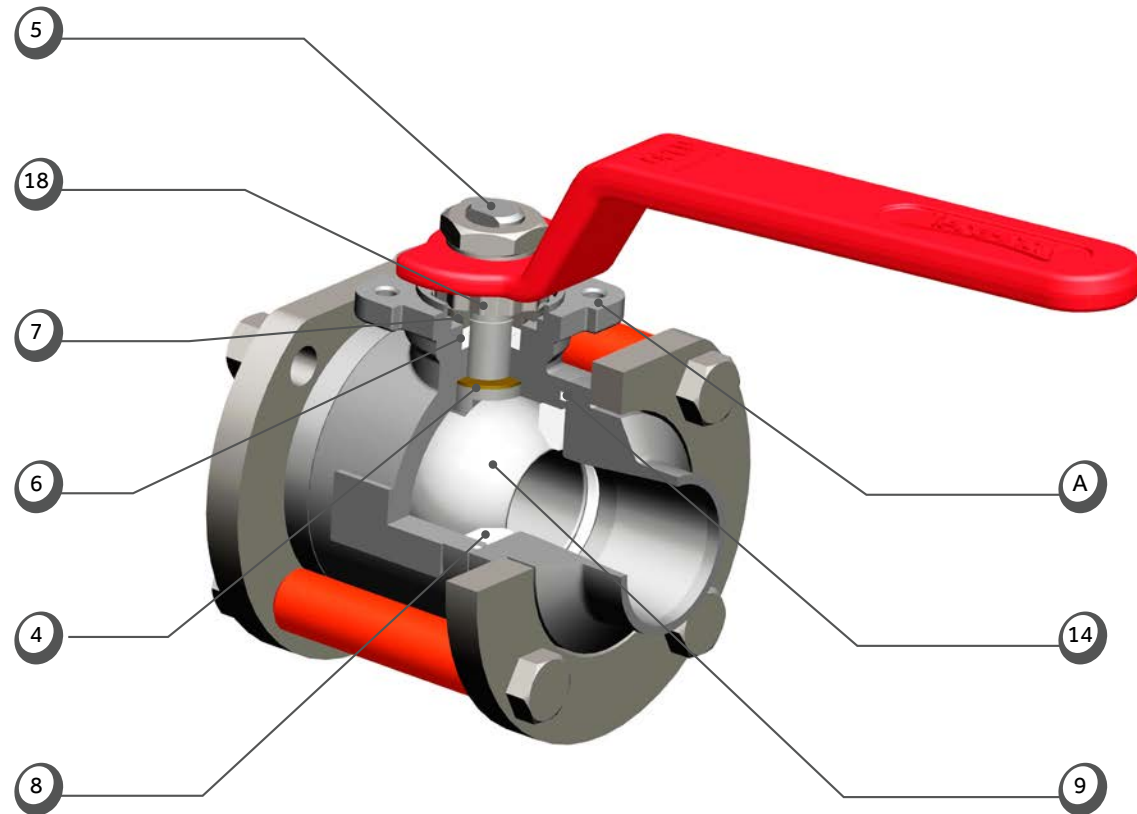

- A • Platine EN ISO 5211**
Elle autorise toute adaptation et les encoches permettent le verrouillage du levier en position ouverte ou fermée.
- 4 • Rondelle de friction**
Elle permet une étanchéité primaire. En PTFE chargé PEEK elle assure une meilleure durée de vie du presse-étoupe. Evite le contact métal/métal entre tige et corps.
- 5 • Tige de manœuvre**
Non éjectable, elle est dimensionnée pour résister à des valeurs de couples élevées sans se déformer ni se casser.
- 6 • Presse-étoupe**
Boîtier usiné et équipé de garnitures de type chevron. Le presse-étoupe est antistatique et agréé TA-Luft.
- 7 • Rondelles Belleville**
Elles assurent le rattrapage d'usure des garnitures du presse-étoupe.
- 8 • Sièges**
Une large variété de matériaux et un design unique permettent l'utilisation de la série PS4 dans des conditions extrêmes (-196° C à +280°C).
- 9 • Boisseau**
Le perçage de l'empreinte de tige permet l'évacuation de toute surpression en position ouverte.
- 14 • Joints de corps**
Encastrés dans le corps, ils assurent l'étanchéité entre le corps et les embouts vers l'extérieur.
- 18 • Freins d'écrous**
Les écrous du presse-étoupe et du levier sont bloqués en rotation interdisant tout desserrage dans le temps.

- A • EN ISO 5211 top flange**
Makes easier the adaptation of an actuator on the valve. This flange has notches to welcome a lockable handle.
- 4 • Stem thrust seal**
Act as a primary sealing. Made of PTFE + PEEK, it ensures a longer lifetime and numerous cycles.
- 5 • Antiblow-out stem**
The stem is designed to resist high operating torques without breaking nor twisting.
- 6 • Gland-packing**
The gland box is machined and receive a V-ring packing. This assembly ensures an antistatic gland-packing, TALUFT certified.
- 7 • Spring washers**
The spring washers act as a spring to compensate the packing wear.
- 8 • Seats**
A wide range of seat materials is available. The PS4 valve can be used in many process applications from -196°C to 280 °C.
- 9 • Ball**
A cavity relief is drilled in the stem groove in order to avoid any overpressure in "Open" position.
- 14 • Encapsulated body seals**
In PTFE, they are giving a reliable sealing between the body and connections.
- 18 • Safety nut lock**
These nut locks ensure to keep the packing nut and the handle nut in place during valve operations.

Les brides de corps tournantes

- Installation simplifiée sans alignement des embouts lors de leur soudure
- Orientation à 360° du corps de vanne
- Suppression des contraintes générées par un défaut d'alignement



Loose body flanges

- Ease of installation without alignment of the end pieces
- Orientation of the valve body through 360°
- Elimination of the stresses due to faulty alignment

Corps de robinet orientable à 360°
Valve body rotatable through 360°

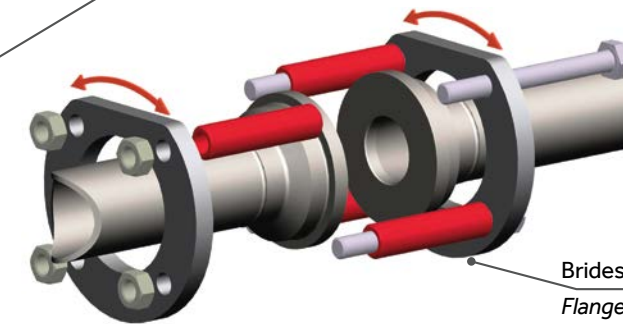

Brides tournantes orientables à 360°
Flanges rotatable through 360°

La boîte Kit

- Gain de temps au montage
- Identification des matériaux par couleurs distinctes
- Protection des composants lors de l'installation

The Kit box

- Save time when fitting
- Identification of the materials by distinct colours
- Protection of the components during installation



Les embouts usinés

- Large choix de raccordement
- Réalisation sur mesure
- Rapidité de fabrication

The machined ends

- Large choice of connections
- Customized dimensions
- Fast production



**ÉTANCHÉITÉ
SEAL**

Tests & essais

Directive DESP

Conformément aux exigences de l'annexe I de la Directive 97/23/CE DESP, nos robinets subissent des contrôles tout au long de la fabrication. Un test hydrostatique final vérifie la tenue sous pression. Nos essais sont réalisés suivant les normes ISO 5208 et NF EN 12266-2 conformes à la Directive DESP.

Emanations fugitives

Nos robinets sont testés suivant la réquisition " TA LUFT " point 3.1.8.4. du 27/02/1986. Les résultats montrent que les taux de fuites sont nettement inférieurs aux niveaux exigés par les normes EN ISO15848-2, notamment avec les réquisitions VDI 2440_2000.

Pression d'essai d'étanchéité Amont/Aval

Le taux de fuite amont/aval, (fuite en ligne), correspond à l'étanchéité entre le boisseau et les sièges.

Il est contrôlé en vérifiant qu'aucune bulle ne s'échappe du volume d'air sous pression emprisonné dans la sphère en position fermée.

Tous nos robinets sont catégorie " A " selon EN 12266-1 : aucune bulle = aucune fuite

Tests

PED directive

According to Pressure European Directive (PED) 97/23/CE, all our ball valves are controlled during the production process. A final hydrostatic pressure test is achieved before dispatch or warehousing. Our tests are conducted according ISO 5208 international standard.

Fugitives Emissions

Our valves are tested according TA LUFT 02/27/1986 (Pt 3.1.8.4) requisition. Measure show leakage rate much lower than the level requested EN ISO15848-2 by regulations such as VDI 2440_2000.

Test pressure of the ball sealing

The upstream/downstream leakage rate, (in-line leakage), is the sealing between the ball and the seats.

We check that absolutely no bubble escape from air pressurized trapped in the volume inside closed ball.

All our valves are "A" Cat.: EN 12266-1 no bubble = no leak

Aval / Downstream

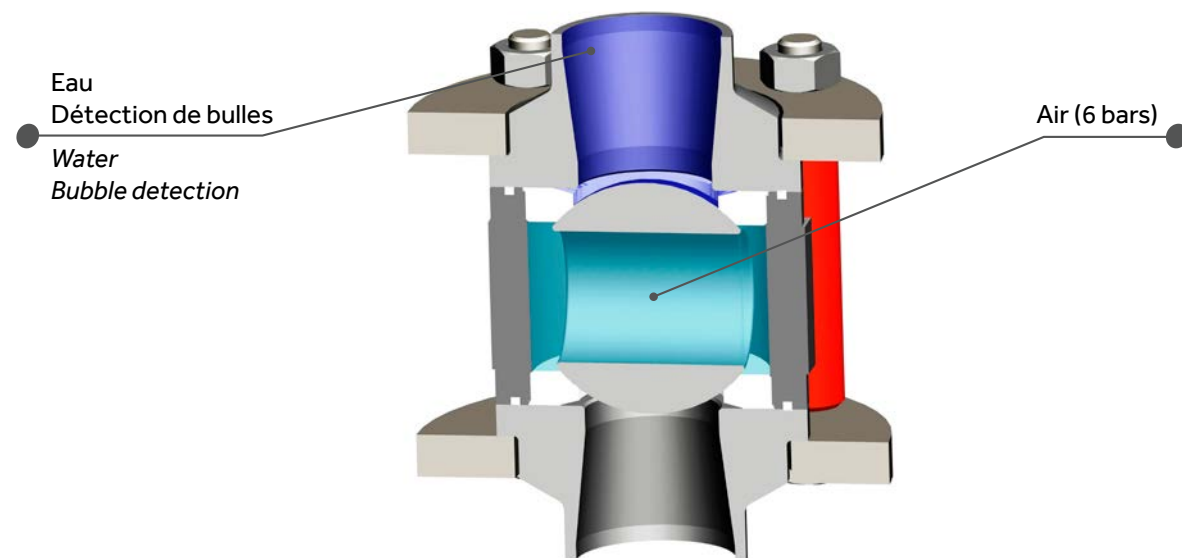

Amont / Upstream

Tenue au vide

La conception et la fabrication de nos robinets 2-pièces et 3-pièces garantissent une tenue à un taux de vide d'au moins de 10^{-3} mbar ($0.75 \cdot 10^{-3}$ Torr).

Vacuum resistance

Design and manufacturing of our 2-piece and 3-piece ball valve allow a vacuum capability of at least 10^{-3} mbar ($0,75 \cdot 10^{-3}$ Torr).

**SYSTÈME D'ÉTANCHÉITÉ
SEALING DESIGN**

Presse-étoupe

Gland-packing

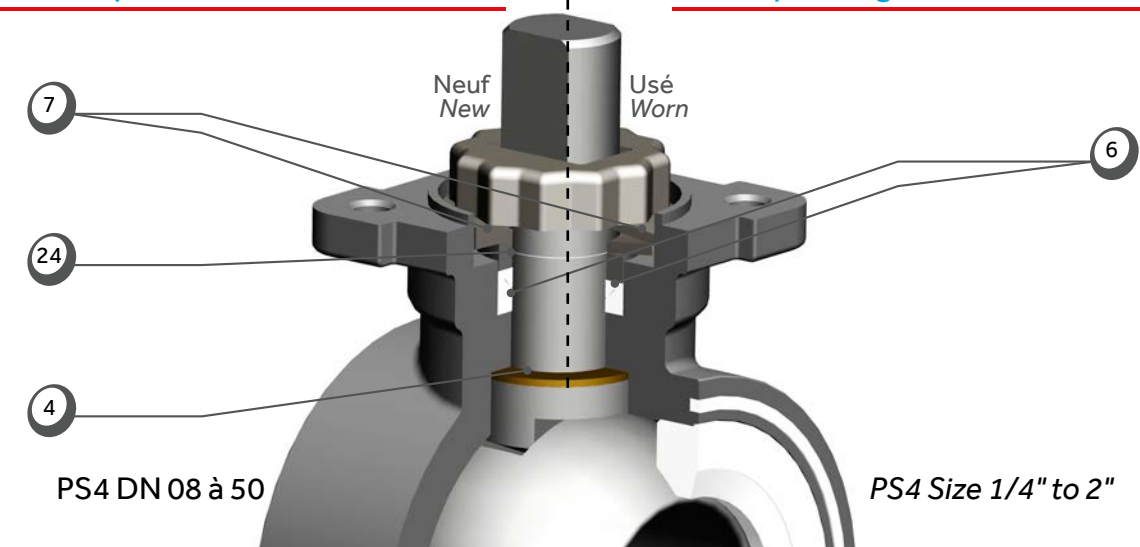

Conception suivant NF EN 12516-1, DIN 3841, AINSI B16.34

Antistatique suivant ISO 7121, NF EN 1983

Garniture antistatique (6) chargée PTFE + carbone + graphite (DN < 50)

Ensemble bille / ressort (B) entre tige & corps et tige & boisseau (DN > 50)

Etanchéité primaire par rondelle de friction (4) en PTFE renforcé PEEK

Etanchéité secondaire par garniture de type "chevron" (6) permettant de maintenir l'étanchéité lorsque la pression vient du corps du robinet

Fouloir inox (24)

Rattrapage du jeu de la garniture par rondelles Belleville (7)

Support siège (20) sur DN > 50

Design according NF EN 12516-1, DIN 3841, AINSI B16.34

Antistatic gland packing according to ISO 7121, NF EN 1983

Gland packing (6) in PTFE+ carbon + graphite (DN < 2")

Ball / spring system (B) between stem & body and stem & ball (DN > 2")

Primary sealing with thrust seal (4) in PEEK reinforced PTFE

Secondary sealing with a "V-ring" packing (6) to allow sealing under pressure coming from the valve body

Gland in stainless steel (24)

Wear compensation by the mean of a pair of spring washers (7)

Seat support (20) on DN > 2"

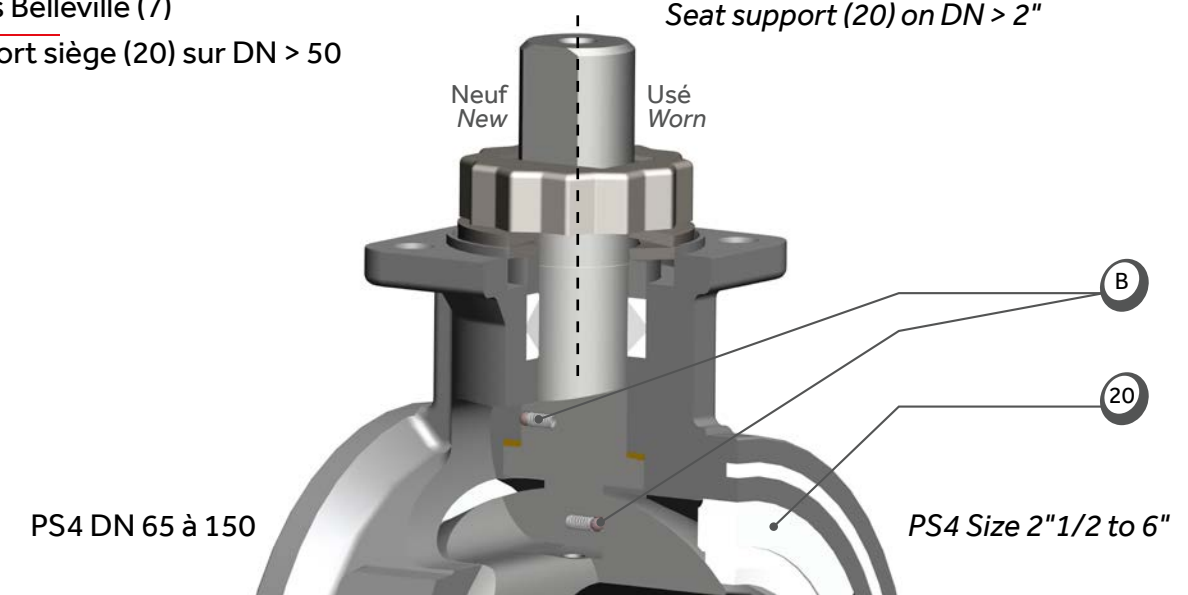

SYSTÈME D'ÉTANCHÉITÉ
SEALING DESIGN

Sièges et joints de corps

Seats and body seals

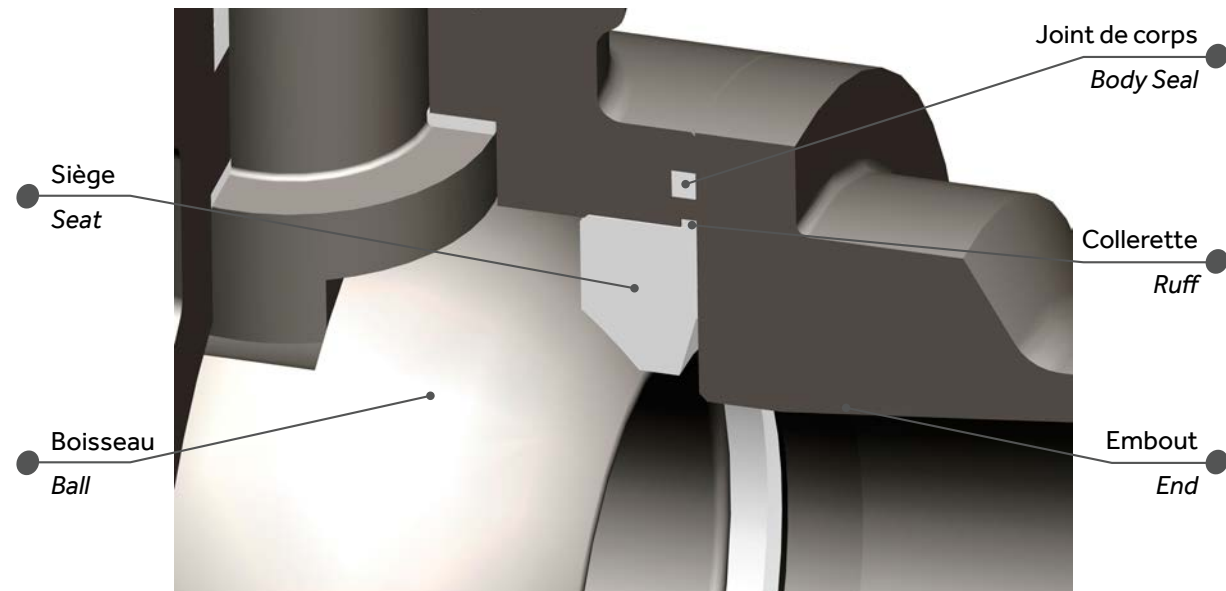

Joint de corps encastrés qui garantissent l'étanchéité intérieur / extérieur.

Des profils de sièges conçus pour une étanchéité amont / aval optimale.

Elasticité des sièges absorbant les contraintes de pression.

Portée progressive qui optimise les couples de manœuvre.

Collerette qui empêche l'extrusion des sièges quand la pression amont est supérieure à la pression aval.

Built-in body seals to guarantee internal/external tightness.

Seats profiles designed for upstream/downstream sealing.

Seats elasticity to absorb pressure stress.

Progressive bearing to optimize operating torques.

Ruff to avoid the seat to be taken away when upstream pressure is higher than downstream pressure.

NOMENCLATURE
COMPONENTS

DN 08 à 50

Size 1/4" to 2"

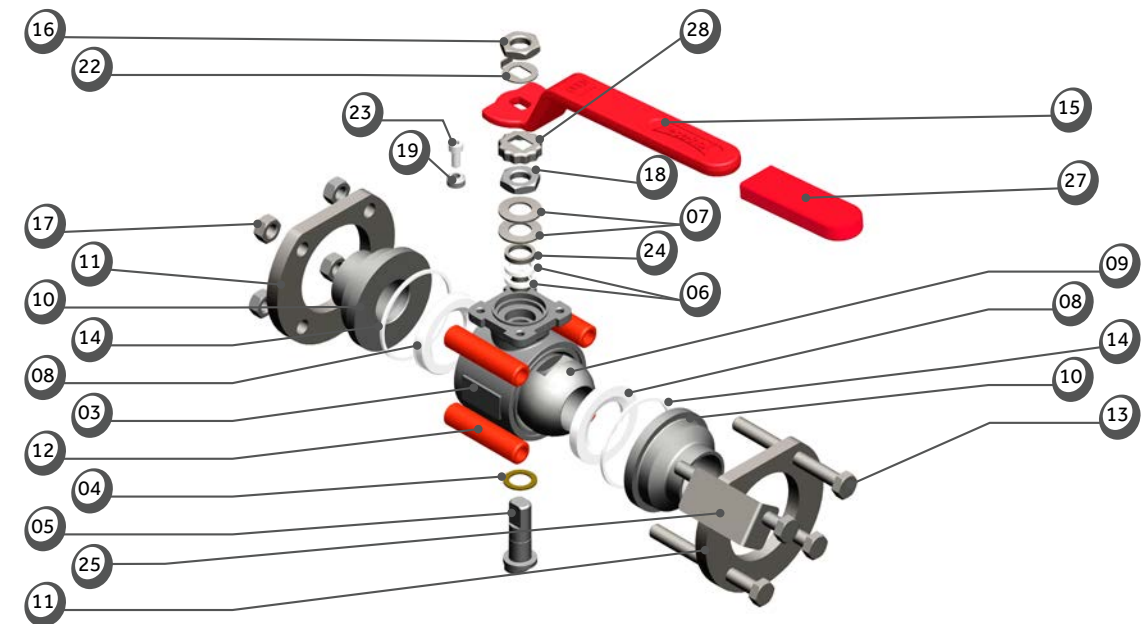

N°	Nb	Description	Matière (EN)		Item	Qty	Description	Material (ASTM)	
			Inox	Acier				S.steel	C.steel
03	1	Corps	1.4409	1.0619 Cataphorésé	03	1	Body	CF3M (316L)	A216 WCB cataphoresis treatment
04	1	Rondelle de friction	PTFE 20% PEEK	PTFE 20% PEEK	04	1	Stem thrust seal	20% PEEK PTFE	20% PEEK PTFE
05	1	Tige de manœuvre	1.4404	1.4404	05	1	Stem	316L	316L
06	1	Garniture presse-étoupe	PTFE 33% C + 2% Gr	PTFE 33% C + 2% Gr	06	1	Gland packing	33%C+2%Gr PTFE	33%C+2%Gr PTFE
		Garniture presse-étoupe (SF)	Graphite	Graphite			Gland packing (FS)	Graphite	Graphite
07	2	Rondelles ressort		1.4310	07	2	Spring washers	301	301
08	2	Sièges	PTFE	PTFE 20% PEEK	08	2	Seats	PTFE	20% PEEK PTFE
09*	1	Tournant sphérique		1.4409	09*	1	Ball		CF3M (316L)
10	2	Embouts libres (DN10 à 25)		1.1151 Cataphorésé	10	2	Loose ends (DN10 to 25)		1020 cataphoresis treatment
		Embouts libres (DN32 à 50)	1.4404	1.0460 Cataphorésé			Loose ends (DN32 to 50)	316L	A105 cataphoresis treatment
		Embouts fixes		1.1151 Cataphorésé			Fixed ends		1020 cataphoresis treatment
		Embouts à bride					Flanged ends		
11	2	Brides tournantes	1.4307	1.0144 Cataphorésé	11	2	Body flange	304L	A 501 cataphoresis treatment
12	4	Entretoises	PTFE rouge	PTFE rouge	12	4	Distance piece	Red PTFE	Red PTFE
13	4	Vis DN10 à 40	1.4301	Classe 8.8	13	4	Screw Size 1/4" to 1"1/2	304	Class 8.8
		Tirants DN50	1.4301	1.4301			Stud Size 2"	304	304
14	2	Joints de corps	PTFE	PTFE	14	2	Body seal	PTFE	PTFE
		Joints de corps (option : SF)	14404 + Graphite	14404 + Graphite			Body seal (option: FS)	316L + Graphite	316L + Graphite
15	1	Levier standard	1.1181	1.1181	15	1	Handle standard	1035	1035
		Levier option	Voir paragraphe OPTIONS DE MANŒUVRE				Handle option	See OPTIONS FOR OPERATION	
16	1	Écrou de levier	1.4404	1.4404	16	1	Lever nut	316L	316L
16b	1	Vis Th de levier DN10	1.4301	1.4301	16b	1	Lever screw DN 10	304	304
Écrous de serrage									
17	4	DN10 à DN40	1.4301	Classe 10.8	17	4	Size 1/4" to 1"1/2	304	Class 10.8
		DN50	1.4301	1.4301			Size 2"	304	304
18	1	Écrou de fouloir	1.4404	1.4404	18	1	Nut gland	316L	316L
19	1	Bague réhaussée de butée	1.4307	1.4307	19	1	Stop ring	304L	304L
22	1	Frein d'écrou de levier	1.4307	1.4307	22	1	Nut stop	304L	304L
23	1	Vis Chc de butée	1.4301	1.4301	23	1	Screw stop	304	304
24	1	Fouloir	1.4404	1.4404	24	1	Gland	316L	316L
25	1	Étiquette identification (option)	1.4307	1.4307	25	1	Identification label (option)	304L	304L
27	1	Manchon de couleur (option)	PVC	PVC	27	1	Color plastic cover (option)	PVC	PVC
28	1	Frein d'écrou de PE	1.4307	1.4307	28	1	Stop nut gland	304L	304L

* Sphère percée en standard
* Drilled ball as standard

**NOMENCLATURE
COMPONENTS**

DN 65 à 150

Size 2"1/2 to 6"

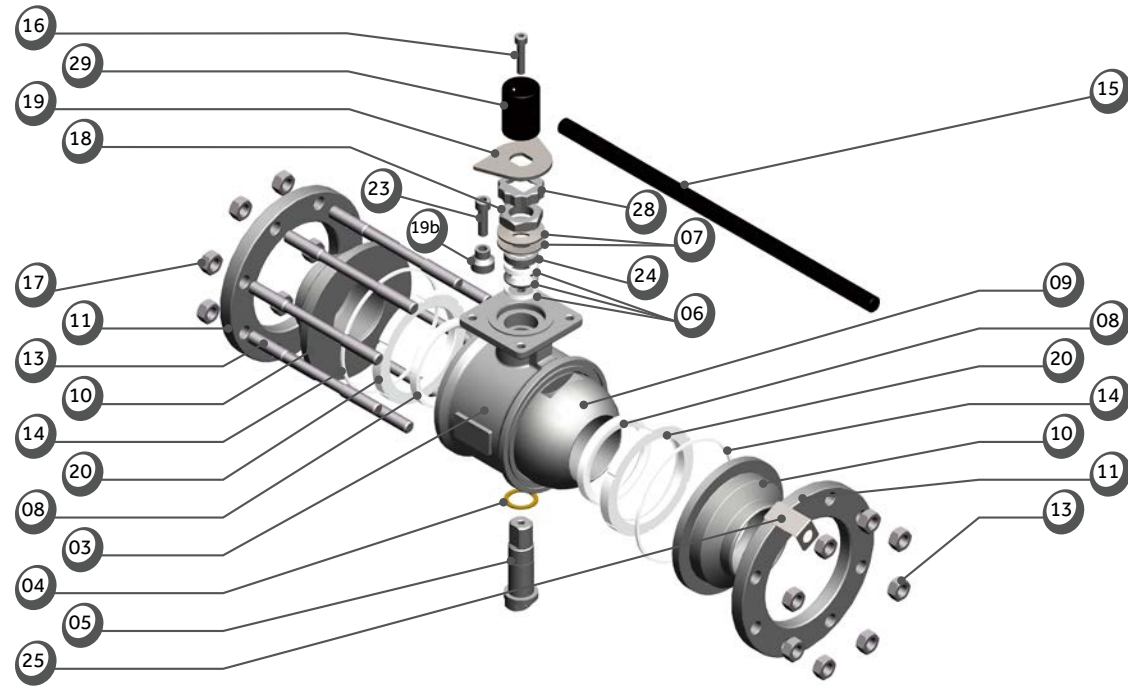

N°	Nb	Description	Matière (EN)		Item	Qty	Description	Material (ASTM)	
			Inox	Acier				S.steel	C.steel
03	1	Corps	1.4409	1.0619 Cataphorésé	03	1	Body	CF3M (316L)	A216WCB cataphoresis treatment
04	1	Rondelle de friction	PTFE 20% PEEK	PTFE 20% PEEK	04	1	Stem thrust seal	20%PEEK PTFE	20%PEEK PTFE
05	1	Tige de manœuvre	1.4404	1.4404	05	1	Stem	316L	316L
06	1	Garniture de presse-étoupe	PTFE	PTFE	06	1	Gland packing	PTFE	PTFE
		Garniture presse-étoupe (SF)	Graphite	Graphite			Gland packing (FS)	Graphite	Graphite
07	2	Rondelles ressort	1.4310	1.4310	07	2	Spring washers	301	301
08	2	Sièges	PTFE	PTFE	08	2	Seats	PTFE	PTFE
09	1	Tournant sphérique	1.4409	1.4409	09	1	Ball	CF3M (316L)	CF3M (316L)
10	2	Emboutis libres (DN65 à 100)	1.4404	1.0460 Cataphorésé	10	2	Loose ends (DN65 to 100)	316L	A105 cataphoresis treatment
		Emboutis libres (DN125 à 150)	1.4404	1.1151 Cataphorésé			Loose ends (DN125 to 150)	1020 cataphoresis treatment	
		Emboutis à bride	1.4404	1.1151 Cataphorésé			Flanged ends	1020 cataphoresis treatment	
11	2	Brides tournantes	1.4307	1.0037 Cataphorésé	11	2	Body flanges	304L	A283 Gr C cataphoresis treatment
13	Tirants		1.4307	1.0060	13	Stud		304L	A572
	12	DN65				Size 2"1/2			
	16	DN80 à DN125				Size 3" to 5"			
	20	DN150				Size 6"			
14	2	Joint de corps	PTFE	PTFE	14	2	Body seal	PTFE	PTFE
		Joint de corps (option : SF)	14404 + Graphite	14404 + Graphite			Body seal (option: FS)	316L + Graphite	316L + Graphite
15	1	Levier standard	1.0037 Cataphorésé		15	1	Handle standard	A283 Gr C cataphoresis treatment	
		Levier option	Voir paragraphe OPTIONS DE MANŒUVRE				Handle option	See OPTIONS FOR OPERATION	
16	1	Vis de levier	1.4301	1.4301	16	1	Handle screw	304	304
17	Écrous de serrage		1.4307	Classe 8.8	17	Nut screw		304L	Class 8.8
	6	DN65				Size 2"1/2			
	8	DN80 à DN125				Size 3" to 5"			
	10	DN150				Size 6"			
18	1	Écrou de fouloir	1.4404	1.4404	18	1	Nut gland	316L	316L
19	1	Plaque d'arrêt	1.4307	1.4307	19	1	Stop plate	304L	304L
19b	1	Bague de butée	1.4307	1.4307	19b	1	Locking plug	304L	304L
20	2	Support de siège	PTFE 25% verre ou 1.4404 (option)		20	2	Seat holder	25% glassfilled PTFE or 316L (option)	
23	1	Vis Chc de butée	1.4301	1.4301	23	1	Stop screw	304	304
24	1	Fouloir	1.4404	1.4404	24	1	Gland	316L	316L
25	1	Étiquette identification (option)	1.4307	1.4307	25	1	Identification label (option)	304L	304L
28	1	Frein d'écrou de P.E	1.4307	1.4307	28	1	Stop nut gland	304L	304L
29	1	Noix de manœuvre standard	1.0037 Cataphorésé	1.0037 Cataphorésé	29	1	Handle adaptor standard	A283 Gr C cataphoresis treatment	
		Noix de manœuvre option	1.4305	1.4305			Handle adaptor option	303	303

* Sphère percée en standard
* Drilled ball as standard

**TYPES DE JOINTS
SEATS & SEALS MATERIAL**

Caractéristiques

PS4 / PN4 : Sièges TFM 1600.
Plage de température -50 °C / +190 °C
PZ4 : Sièges PTFE +20 % PEEK.
Plage de température 0 °C / +280 °C
PP4 : Sièges PEEK.
Plage de température 0 °C / +280 °C

Versions acier au carbone, 316L, 904L (UB6), 304L, Alloy 22.
Version standard :
Perçage boule dans la rainure pour décompression du corps en position ouverte.
Option :
Perçage boule coté amont pour décompression en position fermée.
Agréments :
DESP 97/23/CE
TA-Luft (Conformité aux émanations fugitives)
AD2000 Merkblatt
Matériau des sièges agréé FDA
Options :
ATEX 94/9/CE
Marquage π suivant la directive 2010/35/UE TPED :
certification ADR § 1.8.7.6

Technical data

PS4 / PN4: TFM 1600 seats.
Temperature range: -50°C / +190°C
PZ4: 20% PEEK filled PTFE seats.
Temperature range: 0°C / +280°C
PP4: PEEK seats.
Temperature range: 0°C / +280°C

Carbon steel, 316L, 904L, 304L, Alloy 22 version.
Standard version:
Ball drilling in the stem groove for cavity relief in the open position.
Option:
Upstream vent hole for cavity relief in the closed position.
Approvals:
PED 97/23/CE
TA-Luft (fugitive emissions)
AD2000 Merkblatt
Seat material FDA approved
Options:
ATEX 94/9/CE
π marking according to 2010/35/UE TPED :
certification ADR §1.8.7.6

Courbes Pression/Température

Pressure/Temperature diagrams

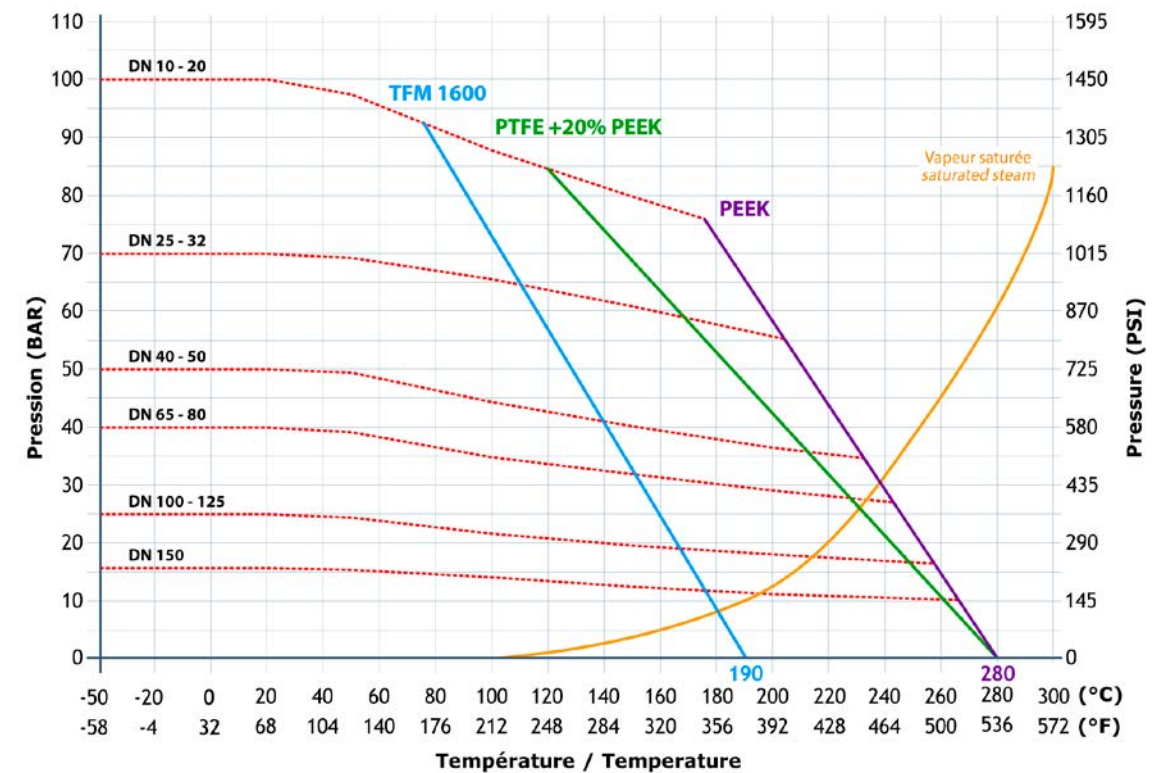

--- tenue mécanique du corps
--- tenue mécanique des sièges

--- mechanical strength of body
--- mechanical strength of seats

-10 °C = limite d'utilisation des robinets en acier carbone standard (1.0619 / A216 WCB)
-46 °C = limite d'utilisation des robinets en acier carbone basse température (1.0566 / A352-LC2-1)
Toutes les valeurs sont données pour passage intégral.

-10 °C = limit the use of standard carbon steel valves (1.0619 / A216 WCB)
-46 °C = limit the use of low temperature carbon steel valves (1.0566 / A352-LC2-1)
All values are given for full bore size.

**TYPES DE JOINTS
SEATS & SEALS MATERIAL**

Caractéristiques

PH4 : Sièges PEHD (Hostalengur / UHMWPE).
Plage de température -50 °C / + 100 °C
PJ4 : Sièges TFM 1600, joints de corps et Presse-étoupe en Fluorosilicone.
Plage de température -80 °C / + 180 °C

Versions inox 316L, 904L (UB6), 304L, Alloy.
Version standard :
PJ4 / PH4 : Perçage boule dans la rainure pour décompression du corps en position ouverte.
PJ4 : Perçage boule coté amont pour décompression en position fermée.
Option :
PH4 : Perçage boule coté amont pour augmenter la décompression en position fermée.
PH4 : Boule sans perçage de décompression
PJ4 : Rehausse type RHJ pour une double étanchéité et un accès à la partie supérieure du calorifuge de tuyauterie.
Agréments :
DESP 97/23/CE
TA-Luft (Conformité aux émanations fugitives)
AD2000 Merkblatt
Matériau des sièges agréé FDA
Options:
ATEX 94/9/CE seulement pour PJ4
Marquage π suivant la directive 2010/35/UE TPED :
certification ADR § 1.8.7.6

Technical data

PH4: Ultra High Molecular Weight Poly Ethylen seats (UHMWPE). Temperature range -50°C / +100°C
PJ4: TFM 1600 seats. Body seal and gland-packing in fluoro-silicon.
Temperature range -80°C / +180°C

316L, 904L, 304L, Alloy version.
Standard version:
PJ4 / PH4: Ball drilling in the stem mark for cavity relief in the open position.
PJ4: Upstream vent hole for cavity relief in the closed position.
Option:
PH4: Upstream vent hole for cavity relief in the closed position.
PH4: Ball without cavity relief
PJ4: Delivered with RHJ stem extension for operation above pipe insulation.
Approvals:
PED 97/23/CE
TA-Luft (fugitive emissions)
AD2000 Merkblatt
Seat material FDA approved
Options: ATEX 94/9/CE only for PJ4
π marking according to 2010/35/UE TPED :
certification ADR §1.8.7.6

Courbes Pression/Température Pressure/Temperature diagrams

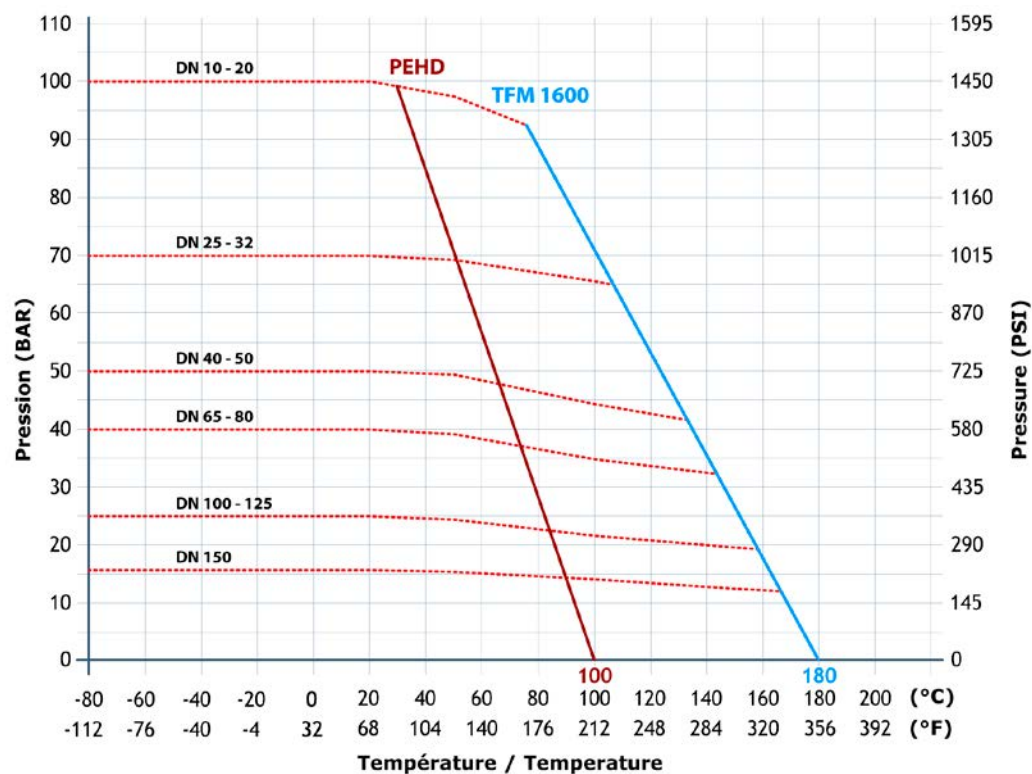

--- tenue mécanique du corps / --- mechanical strength of body
— tenue mécanique des sièges / — mechanical strength of seats
Toutes les valeurs sont données pour passage intégral. / All values are given for full bore size.

**TYPES DE JOINTS
SEATS & SEALS MATERIAL**

Caractéristiques

PY4 : Sièges TF 3215 (PTFE + Carbone).
Plage de température -200 °C / + 200 °C
Version sans rehausse pour applications sans risque de prise en glace.

Versions inox 316L, 904L (UB6), 304L, Alloy.
Version standard :
Perçage boule dans la rainure pour décompression du corps en position ouverte. Perçage boule coté amont pour augmenter la décompression en position fermée.
Agréments :
DESP 97/23/CE
TA-Luft (Conformité aux émanations fugitives)
AD2000 Merkblatt
Options:
ATEX 94/9/CE
Marquage π suivant la directive 2010/35/UE TPED :
certification ADR § 1.8.7.6

Technical data

PY4 : TF 3215 seats (PTFE + Carbon).
Temperature range: -200°C / +200°C
Version without extension for applications without risk of freezing.

316L, 904L, 304L, Alloy version.
Standard version:
Ball drilling in the stem mark for cavity relief in the open position. Upstream vent hole for cavity relief in the closed position.
Approvals:
PED 97/23/CE
TA-Luft (fugitive emissions)
AD2000 Merkblatt
Options:
ATEX 94/9/CE
π marking according to 2010/35/UE TPED :
certification ADR §1.8.7.6

Courbes Pression/Température Pressure/Temperature diagrams

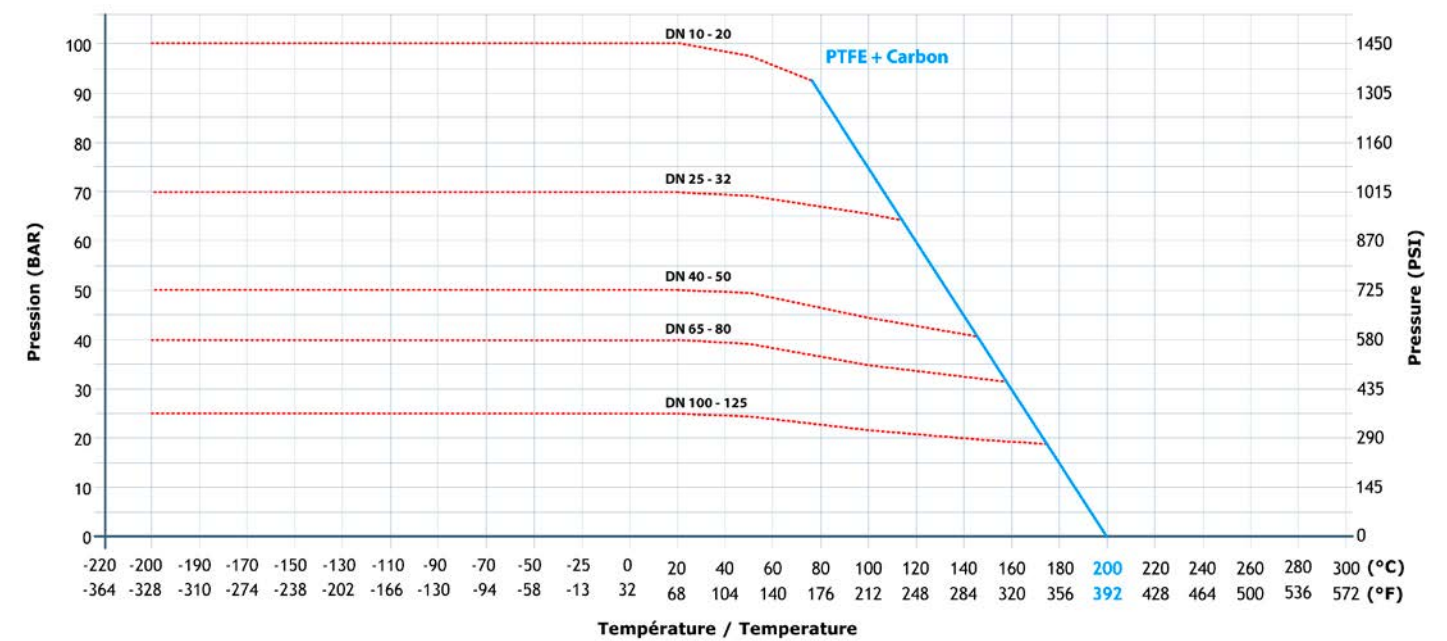

--- Tenue mécanique du corps / --- mechanical strength of body
— Tenue mécanique des sièges / — mechanical strength of seats
Toutes les valeurs sont données pour passage intégral. / All values are given for full bore size.

**TYPES DE JOINTS
SEATS & SEALS MATERIAL**

DN 10 à 50 | Size 1/4" to 2"

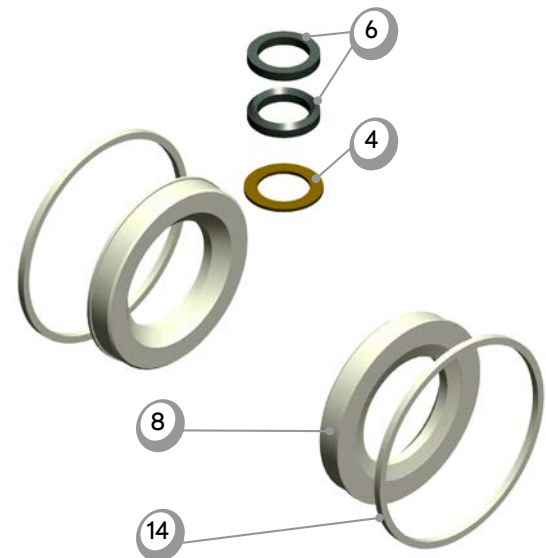

- 8 • 2 sièges
- 14 • 2 joints de corps
- 6 • 1 garniture de presse-étoupe : DN 10 à 50 = 2 parties
DN 65 à 200 = 3 parties
- 4 • 1 rondelle de friction

DN 65 à 200 | Size 2"1/2 to 8"

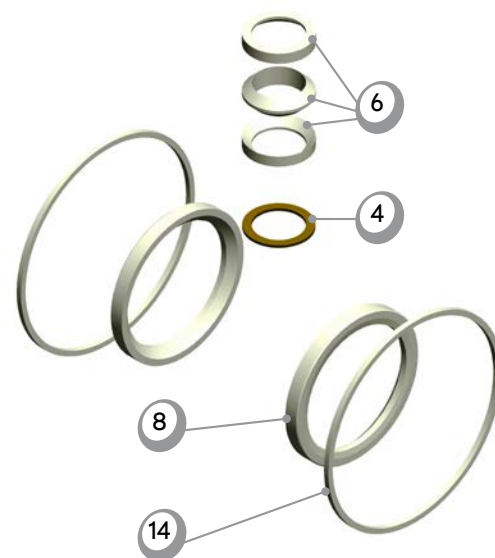

- 8 • 2 seats
- 14 • 2 body seats
- 6 • 1 gland-packaging: size 3/8" to 2" = 2 parts
size 2"1/2 to 8" = 3 parts
- 4 • 1 stem thrust seat

Rep - Robinet Item - Valve type	04	06	08	14
PS4 DN 10 à DN 50 / PS4 DN 1/4" to DN 2"				
PH4	PE HD	PE HD	PE HD	PE HD
PJ4	PTFE 20% PEEK 20%PEEK PTFE	Fluorosilicone	TFM 1600	Fluorosilicone
PN4	PTFE 20% PEEK 20%PEEK PTFE	PTFE 33% C + 2% Gr 33%C+2%Gr PTFE	TFM 1600	PTFE
PP4	PEEK	PTFE 33% C + 2% Gr 33%C+2%Gr PTFE	PEEK	PTFE
PS4	PTFE 20% PEEK 20%PEEK PTFE	PTFE 33% C + 2% Gr 33%C+2%Gr PTFE	TFM 1600	PTFE
PY4	PTFE 20% PEEK 20%PEEK PTFE	PTFE 33% C + 2% Gr 33%C+2%Gr PTFE	PTFE+Carbone PTFE+Carbon	PTFE
PZ4	PTFE 20% PEEK 20%PEEK PTFE	PTFE 33% C + 2% Gr 33%C+2%Gr PTFE	PTFE 20% PEEK 20%PEEK PTFE	PTFE
PS4 DN 65 à DN 200 / PS4 DN 2"1/2 to DN 8"				
PH4	PE HD	PE HD	PE HD	PE HD
PJ4	PTFE 20% PEEK 20%PEEK PTFE	Fluorosilicone	TFM 1600	Fluorosilicone
PN4	PTFE 20% PEEK 20%PEEK PTFE	PTFE	TFM 1600	PTFE
PP4	PEEK	PTFE	PEEK	PTFE
PS4	PTFE 20% PEEK 20%PEEK PTFE	PTFE	TFM 1600	PTFE
PY4	PTFE 20% PEEK 20%PEEK PTFE	PTFE	PTFE+Carbone PTFE+Carbon	PTFE
PZ4	PTFE 20% PEEK 20%PEEK PTFE	PTFE	PTFE 20% PEEK 20%PEEK PTFE	PTFE

**VALEURS KV - CODIFICATION
VALUES KV - CODIFICATION**

VALEURS KV | KV VALUES

Passage intégral / Full bore

DN	Size	ΔP= 1 bar Kv (m ³ /h)	ΔP=0.001 bar débit / flow (m ³ /h)
8	1/4"	6	0.19
12	3/8"	8	0.25
15	1/2"	13	0.40
20	3/4"	26	0.81
25	1"	46	1.47
32	1"1/4"	82	2.59
40	1"1/2"	120	3.81
50	2"	223	7.07
65	2"1/2"	423	13.37
80	3"	617	19.52
100	4"	1154	36.49
125	5"	1883	59.56
150	6"	2844	89.95

Coefficient de débit : Kv
 $Kv = Q \cdot \sqrt{d/\Delta P}$ exprimé en m³/h
 ΔP = perte de charge en bar
 Q = débit volumique exprimé en m³/h
 d = densité du fluide
 $\Delta P = d(Q/Kv)^2$
 $Q = Kv \cdot \sqrt{\Delta P/d}$

Passage Standard / Reduced bore

DN	Size	ΔP= 1 bar Kv (m ³ /h)	ΔP=0.001 bar débit / flow (m ³ /h)
15	1/2"	8	0.25
20	3/4"	13	0.40
25	1"	26	0.81
32	1"1/4"	46	1.47
40	1"1/2"	82	2.59
50	2"	120	3.81
65	2"1/2"	223	7.07
80	3"	397	12.56
100	4"	560	17.71
125	5"	942	29.80
150	6"	1433	45.32
200	8"	2011	63.60

Flow coefficient: Kv
 $Kv = Q \cdot \sqrt{d/\Delta P}$ in m³/h
 ΔP = pressure drop in bar
 Q = flow in volum in m³/h
 d = density
 $\Delta P = d(Q/Kv)^2$
 $Q = Kv \cdot \sqrt{\Delta P/d}$

CODIFICATION | CODIFICATION

Type de sièges Seats	Type d'embout Body flange	Raccordement Connection	Passage Bore	Matière Material
PS4 TFM 1600	L Libre Loose ends	BW A souder en bout Butt Welding	V Standard Reduced bore	A Acier Carbon steel
PZ4 PTFE 20% PEEK 20%PEEK PTFE	T Voie affleurante Flush mounted	CL Clamp Clamp ends	N Nominal Full bore	I Inox / Stainless steel 316L
PP4 PEEK		DB Double Bague Compression fittings	T Passage direct True Bore	F Taux de Ferrite < 1% Low Ferrite < 1%
PN4 TFM 1600		FB 3/8" NPSM	S Inversé Inverted	U Uranus B6 904L
PY4 Cryogénique Cryo special		FC Fond de Cuve Tank bottom		H Alloy C22
PJ4 TFM 1600		SW A souder emboîté Socket Welding		J Inox / Stainless steel 304L
PH4 PE Hostalen Gür UHMWPE		TB Taraudé Briggs NPT threaded		D Super Duplex 1.4410
		TG Taraudé Gaz BSP threaded		C Duplex 1.4462
		O4 Soudure Orbitale Orbital welding		

Sur demande
 - mixage des embouts possible
 - autres matériaux
 - embouts spécifiques

Upon request
 - Mix of connections
 - others materials
 - specific ends

RACCORDEMENTS
TYPE OF CONNECTIONS

A souder en bout

DN 15 à 65
Passage Standard
Tube ISO

Butt Weld

Size 1/2" to 2 1/2"
Reduced bore
ISO pipe

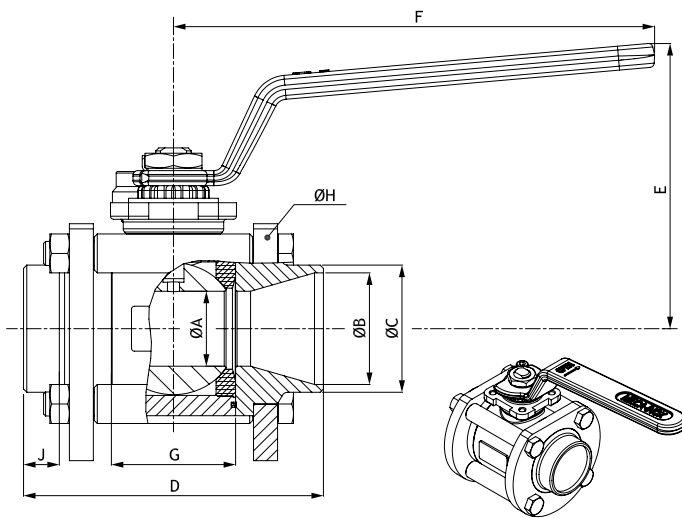

A souder en bout

DN 08 à 50
Passage intégral
Tube ISO

Butt Weld

Size 1/4" to 2"
Full bore
ISO pipe

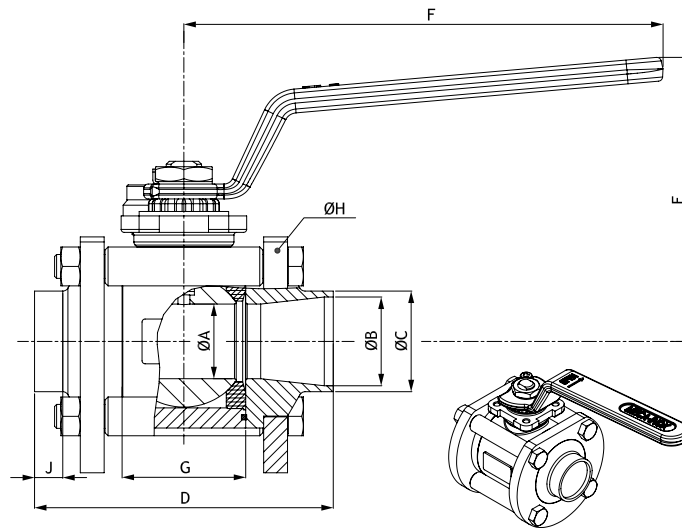

DN Size	PN	Ø A	Ø B		Ø C	D	E	F	G	Ø H	J	ISO 5211	Poids (Kg) Weight (Kg)	
			Inox S.Steel	Acier C.Steel										
V • Passage Standard / Reduced bore														
15	1/2"	100	11.1	17.3	15.5	21.3	65	70	120	20.4	56	8.5	F03	0.650
20	3/4"	100	14	22.9	20.5	26.9	70	73	120	24.4	63	8.8	F03	0.800
25	1"	100	19	29.7	27.3	33.7	85	91	160	31.6	80	9.1	F04	1.610
32	1 1/4"	70	25	37.2	34.4	42.4	100	95	160	41.4	88	11.9	F04	2.100
40	1 1/2"	70	32	43.1	40.3	48.3	110	111	190	48.2	104	10.9	F05	3.120
50	2"	50	38	54.5	52.3	60.3	125	116	190	56.2	117	14.1	F05	4.300
65	2 1/2"	50	50	70.3	66.1	76.1	150	137	230	71	148	13.2	F07	8.590
N • Passage intégral / Full bore														
08	1/4"	100	11.1	9.5	8.9	13.5	65	70	120	20.4	56	6.4	F03	0.640
12	3/8"	100	11.1	13.2	12.6	17.2	65	70	120	20.4	56	7.3	F03	0.640
15	1/2"	100	14	17.3	15.5	21.3	70	73	120	24.4	63	7.3	F03	0.800
20	3/4"	100	19	22.9	20.5	26.9	85	91	160	31.6	80	7.2	F04	1.610
25	1"	70	25	29.7	27.3	33.7	100	95	160	41.4	88	9.4	F04	2.080
32	1 1/4"	70	32	37.2	34.4	42.4	110	111	190	48.2	104	9.2	F05	3.310
40	1 1/2"	50	38	43.1	40.3	48.3	125	116	190	56.2	117	10.7	F05	4.270
50	2"	50	50	54.5	52.3	60.3	150	137	230	71	148	8.6	F07	8.690

RACCORDEMENTS
TYPE OF CONNECTIONS

A souder en bout

DN 80 à 200
Passage Standard
Tube ISO

Butt Weld

Size 3" to 8"
Reduced bore
ISO pipe

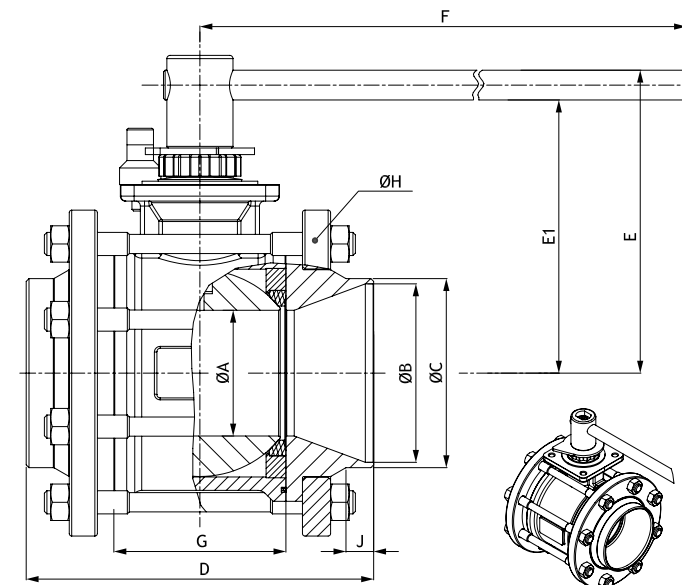

A souder en bout

DN 65 à 150
Passage intégral
Tube ISO

Butt Weld

Size 2 1/2" to 6"
Full bore
ISO pipe

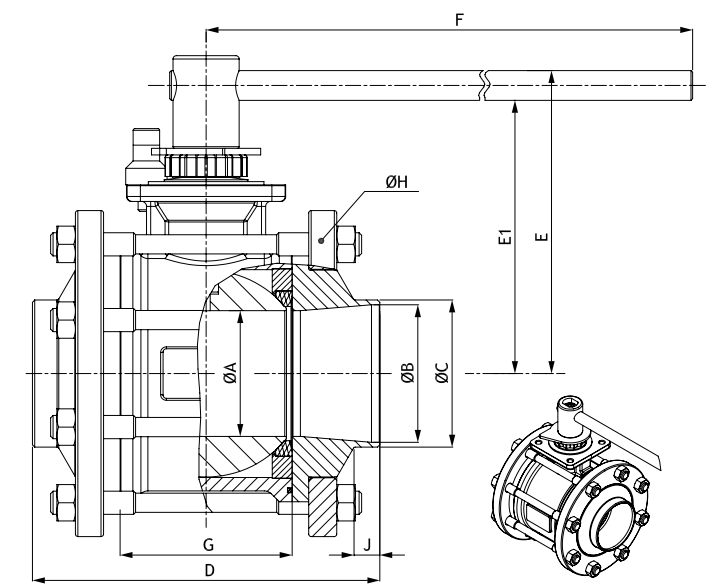

DN Size	PN	Ø A	Ø B		Ø C	D	E	E1	F	G	Ø H	J	ISO 5211	Poids (Kg) Weight (Kg)	
			Inox S.Steel	Acier C.Steel											
V • Passage Standard / Reduced bore															
80	3"	40	64	83.1	78.9	88.9	180	171	153	370	84	174	12.8	F07	14.840
100	4"	40	76	107.9	101.7	114.3	210	182	165	440	104	197	16.4	F10	22.310
125	5"	25	100	133.7	131.7	139.7	230	204	184	505	130	236	12.9	F10	33.980
150	6"	25	125	162.3	159.3	168.3	260	248	221	710	157	288	11.6	F12	57.940
200	8"	16	150	211.5	207.9	219	290	270	243	710	185	324	12.1	F12	78.900
N • Passage intégral / Full bore															
65	2 1/2"	40	64	70.3	66.3	76.1	180	171	153	370	84	174	14.4	F07	14.800
80	3"	40	76	83.1	78.9	88.9	210	182	165	440	104	197	14.9	F10	22.510
100	4"	25	100	107.9	101.7	114.3	230	204	184	505	130	236	12.7	F10	34.360
125	5"	25	125	133.7	131.7	139.7	260	248	221	710	157	288	12.6	F12	58.430
150	6"	16	150	162.3	159.3	168.3	290	270	243	710	185	324	10.9	F12	80.860

RACCORDEMENTS
TYPE OF CONNECTIONS

A souder emboité

DN 15 à 65
Passage Standard

Socket Weld

Size 1/2" to 2 1/2"
Reduced bore

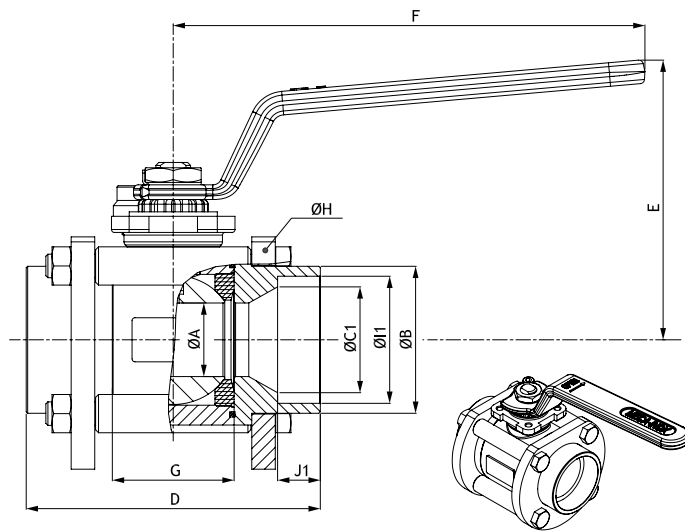

A souder emboité

DN 08 à 50
Passage intégral

Socket Weld

Size 1/4" to 2"
Full bore

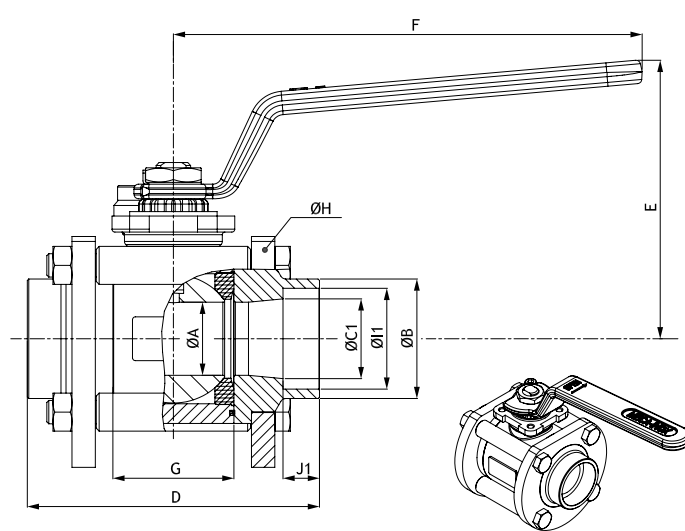

DN Size	PN	Ø A	Ø B	Ø C1	D	E	F	G	Ø H	Ø I1	J1	ISO 5211	Poids (Kg) Weight (Kg)	
V • Passage Standard / Reduced bore														
15	1/2"	100	11.1	27.0	16.1	65	70	120	20.4	56	21.9	10.5	F03	0.650
20	3/4"	100	14	33.0	21.7	70	73	120	24.4	63	27.3	13.5	F03	0.810
25	1"	100	19	42.0	27.3	85	91	160	31.6	80	34.0	13.5	F04	1.610
32	1 1/4"	70	25	50.0	36.0	100	95	160	41.4	88	42.8	14.5	F04	2.080
40	1 1/2"	70	32	56.0	41.9	110	111	190	48.2	104	48.9	16.0	F05	3.270
50	2"	50	38	69.0	53.1	125	116	190	56.2	117	61.3	17.5	F05	4.220
65	2 1/2"	50	50	85.0	68.9	150	137	230	71	148	77.1	19.0	F07	8.380
N • Passage intégral / Full bore														
08	1/4"	100	11.1	19.6	11.1	65	70	120	20.4	56	14.3	10.5	F03	0.650
12	3/8"	100	11.1	24.0	12.6	65	70	120	20.4	56	17.8	10.5	F03	0.650
15	1/2"	100	14	29.0	16.1	70	73	120	24.4	63	21.9	10.5	F03	0.810
20	3/4"	100	19	34.3	21.7	85	91	160	31.6	80	27.3	13.5	F04	1.610
25	1"	70	25	41.0	27.3	100	95	160	41.4	88	34.0	13.5	F04	2.110
32	1 1/4"	70	32	49.8	36.0	110	111	190	48.2	104	42.8	14.5	F05	3.320
40	1 1/2"	50	38	55.9	41.9	125	116	190	56.2	117	48.9	16.0	F05	4.270
50	2"	50	50	69.2	53.1	150	137	230	71	148	61.3	17.5	F07	8.640

RACCORDEMENTS
TYPE OF CONNECTIONS

A souder emboité

DN 80 à 200
Passage Standard

Socket Weld

Size 3" to 8"
Reduced bore

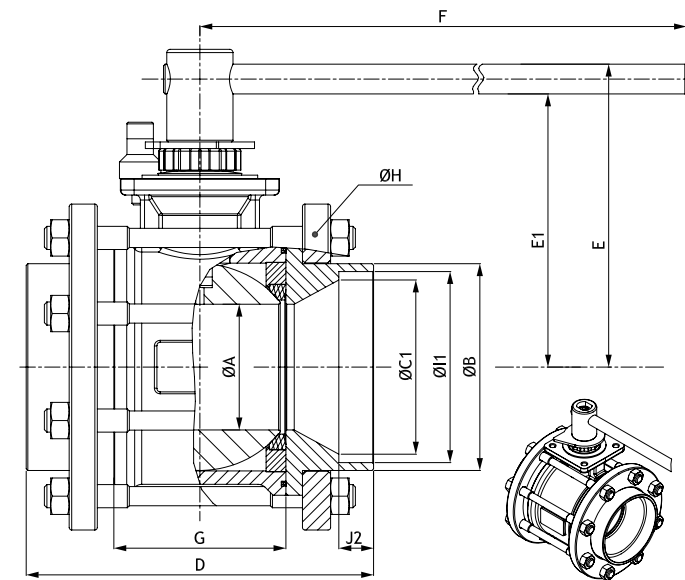

A souder emboité

DN 65 à 150
Passage intégral

Socket Weld

Size 2 1/2" to 6"
Full bore

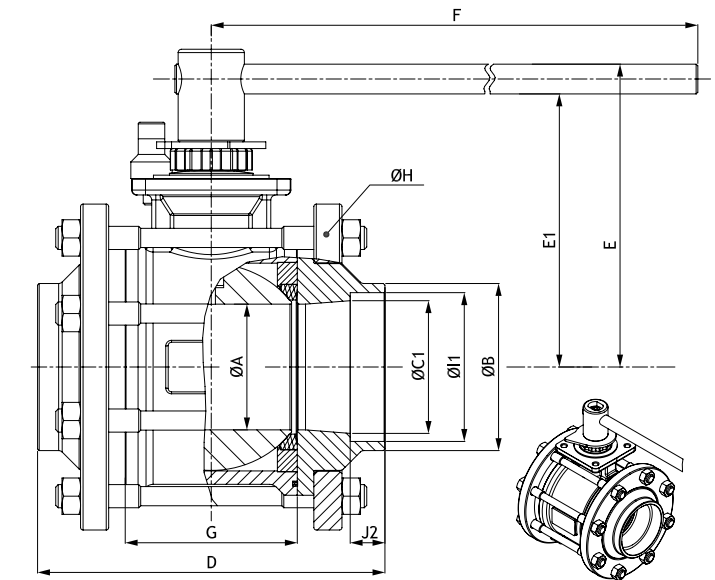

DN Size	PN	Ø A	Ø B	Ø C1	D	E	E1	F	G	Ø H	Ø I1	J2	ISO 5211	Poids (Kg) Weight (Kg)	
V • Passage Standard / Reduced bore															
80	3"	40	64	101	81	180	171	153	370	84	174	89.9	21	F07	14.700
100	4"	40	76	125	105.3	210	182	165	440	104	197	115.5	21	F10	22.010
125	5"	25	100	148.5	135	230	204	184	505	130	236	141.3	24	F10	32.820
150	6"	25	125	177.5	164	260	248	221	710	157	288	171.3	24	F12	56.140
200	8"	16	150	229	214	290	270	243	710	185	324	221.8	30	F12	74.290
N • Passage intégral / Full bore															
65	2 1/2"	40	64	87	69	180	171	153	370	84	174	77.6	19	F07	14.890
80	3"	40	76	101	81	210	182	165	440	104	197	89.9	21	F10	22.750
100	4"	25	100	127.5	105.3	230	204	184	505	130	236	115.5	21	F10	34.35
125	5"	25	125	148.5	135	260	248	221	710	157	288	141.3	24	F12	57.120
150	6"	16	150	177.5	164	290	270	243	710	185	324	171.3	24	F12	80.040

RACCORDEMENTS
TYPE OF CONNECTIONS

Tarudé BSP (TG) & NPT (TB)

DN 15 à 65
Passage Standard

BSP (TG) & NPT (TB) thread

Size 1/2" to 2"1/2
Reduced bore

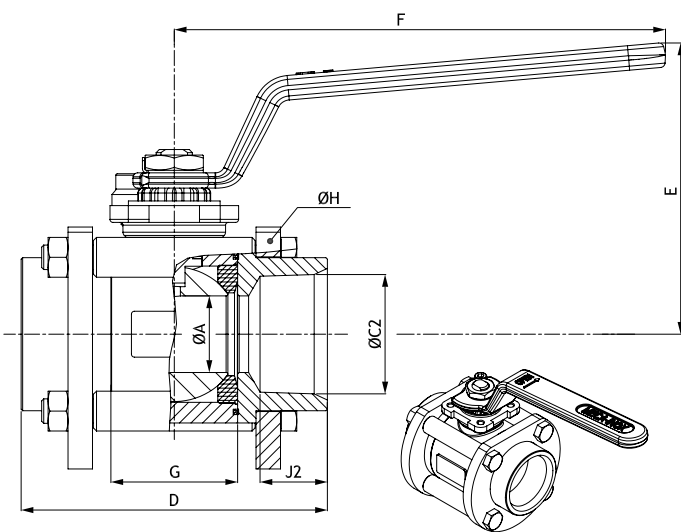

Tarudé BSP (TG) & NPT (TB)

DN 08 à 50
Passage intégral

BSP (TG) & NPT (TB) thread

Size 1/4" to 2"
Full bore

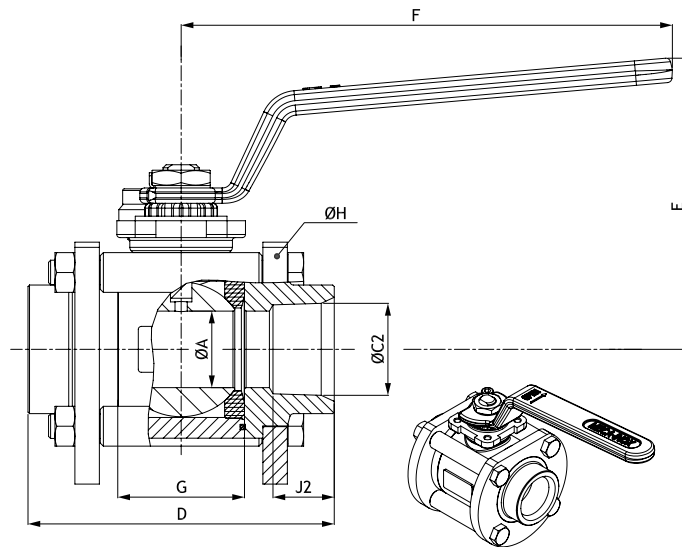

DN Size	PN	Ø A	Ø C2		D	E	F	G	Ø H	J2	ISO 5211	Poids (Kg) Weight (Kg)	
			GAZ BSP "P"	NPT NPT									
V • Passage Standard / Reduced bore													
15	1/2"	100	11.1	1/2"	1/2"	65	70	120	20.4	56	16	F03	0.640
20	3/4"	100	14	3/4"	3/4"	70	73	120	24.4	63	16	F03	0.800
25	1"	100	19	1"	1"	85	91	160	31.6	80	20	F04	1.600
32	1"1/4	70	25	1"1/4	1"1/4	100	95	160	41.4	88	22	F04	2.050
40	1"1/2	70	32	1"1/2	1"1/2	110	111	190	48.2	104	22	F05	3.270
50	2"	50	38	2"	2"	125	116	190	56.2	117	25	F05	4.160
65	2"1/2	50	50	2"1/2	2"1/2	150	137	230	71	148	30	F07	7.730
N • Passage intégral / Full bore													
08	1/4"	100	11.1	1/4"	1/4"	65	70	120	20.4	56	12	F03	0.700
12	3/8"	100	11.1	3/8"	3/8"	65	70	120	20.4	56	12	F03	0.680
15	1/2"	100	14	1/2"	1/2"	70	73	120	24.4	63	16	F03	0.980
20	3/4"	100	19	3/4"	3/4"	85	91	160	31.6	80	16	F04	1.690
25	1"	70	25	1"	1"	100	95	160	41.4	88	20	F04	2.120
32	1"1/4	70	32	1"1/4	1"1/4	110	111	190	48.2	104	22	F05	3.320
40	1"1/2	50	38	1"1/2	1"1/2	125	116	190	56.2	117	22	F05	4.380
50	2"	50	50	2"	2"	150	137	230	71	148	25	F07	8.840

RACCORDEMENTS
TYPE OF CONNECTIONS

Tarudé BSP (TG) & NPT (TB)

DN 80 à 100
Passage Standard

BSP (TG) & NPT (TB) thread

Size 3" to 4"2
Reduced bore

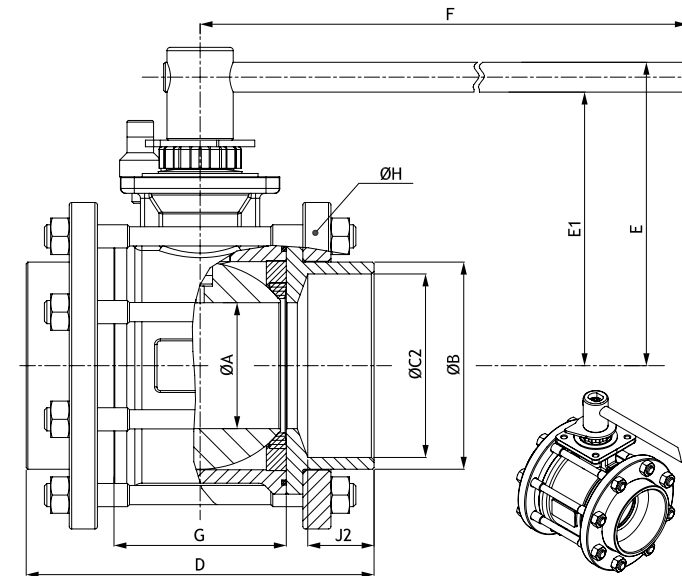

Tarudé BSP (TG) & NPT (TB)

DN 65 à 100
Passage intégral

BSP (TG) & NPT (TB) thread

Size 2"1/2 to 4"
Full bore

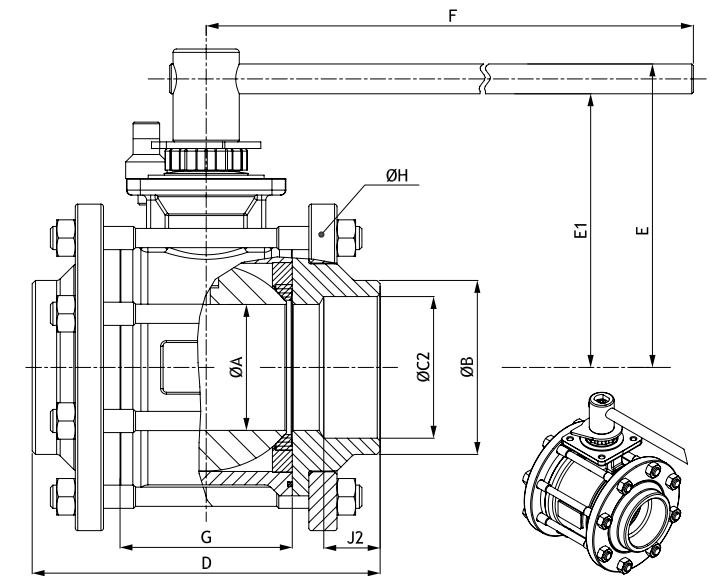

DN Size	PN	Ø A	Ø B	Ø C2		D	E	E1	F	G	Ø H	J2	ISO 5211	Poids (Kg) Weight (Kg)	
				GAZ BSP "P"	NPT NPT										
V • Passage Standard / Reduced bore															
80	3"	40	64	107	3"	3"	180	171	153	370	84	174	34	F07	14.940
100	4"	40	76	125	4"	4"	210	182	165	440	104	197	40	F10	21.590
N • Passage intégral / Full bore															
65	2"1/2	40	64	85	2"1/2	2"1/2	180	171	153	370	84	174	31	F07	15.000
80	3"	40	76	105	3"	3"	210	182	165	440	104	197	34	F10	22.950
100	4"	25	100	130	4"	4"	230	204	184	505	130	236	40	F10	34.740

RACCORDEMENTS
TYPE OF CONNECTIONS

Double bagues

DN 06 à 18
Passage intégral
Installation rapide et facile
(simple serrage sans soudure)

Compression fittings

Size 06 to 18
Full bore
Fast and easy valve installation
(nut screwing without welding)

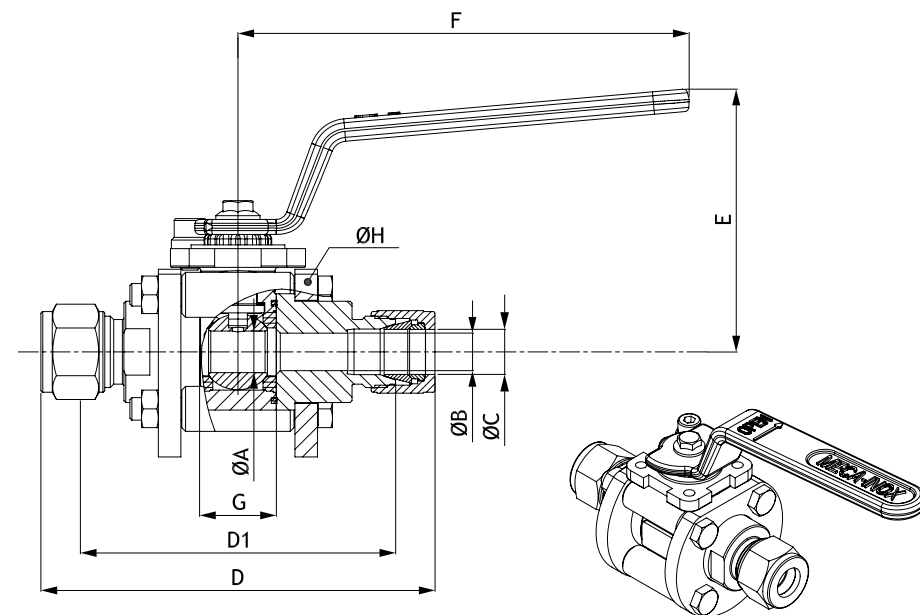

DN Size	PN	Ø A	Ø B	Ø C	D	D1	E	F	G	Ø H	ISO 5211
06	100	11.1	4.8	OD 6	98	83.2	70	120	20.4	56	F03
08	100	11.1	6.4	OD 8	98	83	70	120	20.4	56	F03
10	100	11.1	7.9	OD 10	99.6	84.4	70	120	20.4	56	F03
12	100	11.1	9.8	OD 12	104.7	84.5	70	120	20.4	56	F03
1/2"(OD)	100	11.1	9.8	OD 1/2"	104.7	84.5	70	120	20.4	56	F03
18	100	14	14	OD 18	113.8	93.6	73	120	24.4	63	F03

RACCORDEMENTS
TYPE OF CONNECTIONS

A clamp

DN 08 à 150

Triclamp ends

Size 1/4" to 6"

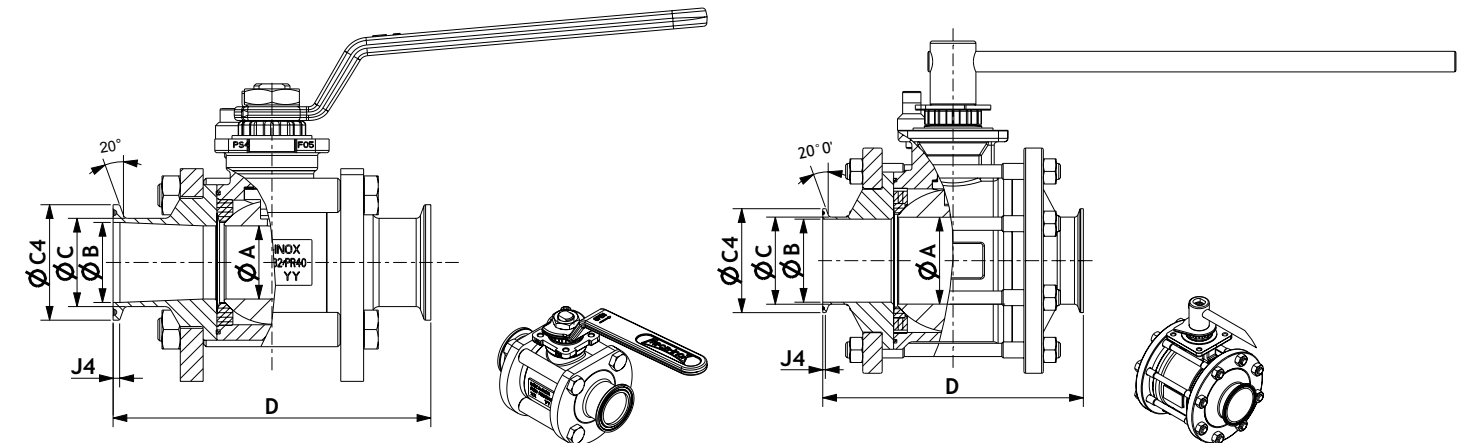

Sur demande : dimensions suivant Normes :
ISO / DIN / BSOD / SMS / MICRO-CLAMP / KF

On request: following dimensions standards:
ISO / DIN / BSOD / SMS / MICRO-CLAMP / KF

DN Size	ØA	D	J4	ISO (2004)			DIN (11850 Row2)			BSOD			SMS (3008)			
				ØB	ØC	ØC4	ØB	ØC	ØC4	ØB	ØC	ØC4	ØB	ØC	ØC4	
08	1/4"	11.1	89	2.85	10.3	13.5	25	8	10	25	4.62	6.4	25	8	10	25
12	3/8"	11.1	89	2.85	14	17.2	25	10	12	25	-	-	-	10	12	25
15	1/2"	14	101	2.85	18.1	21.3	50.5	16	19	50.5	10.92	12.7	25	16	18	50.5
20	3/4"	19	114	2.85	23.7	26.9	50.5	20	23	50.5	15.75	19.05	25	20	22	50.5
25	1"	25	114	2.85	29.7	33.7	50.5	26	29	50.5	22.1	25.4	50.5	22.6	25	50.5
32	1"1/4	32	139	2.85	41.4	45.4	64	32	35	50.5	-	-	-	31.3	33.7	64
40	1"1/2	38	159	2.85	44.3	48.3	64	38	41	50.5	34.8	38.1	50.5	35.6	38	64
50	2"	50	164	2.85	56.3	60.3	77.5	50	53	64	47.5	50.8	64	48.6	51	77.5
65	2"1/2	65	202	2.85	71.5	76.1	91	66	70	91	60.2	63.5	77.5	60.3	63.5	91
80	3"	76	228	2.85	84.3	88.9	106	81	85	106	72.9	76.2	91	72.9	76.1	106
100	4"	100	256	2.85	-	-	-	100	104	119	97.4	101.6	119	-	-	-
125	5"	125	309	5.6	-	-	-	-	-	-	-	-	-	-	-	-
150	6"	150	337	5.6	-	-	-	-	-	-	-	-	-	-	-	-

RACCORDEMENTS
TYPE OF CONNECTIONS

Soudure orbitale

DN 08 à 50
Passage intégral
Tube ISO

Orbital welding

Size 1/4" to 2"
Full bore
ISO pipe

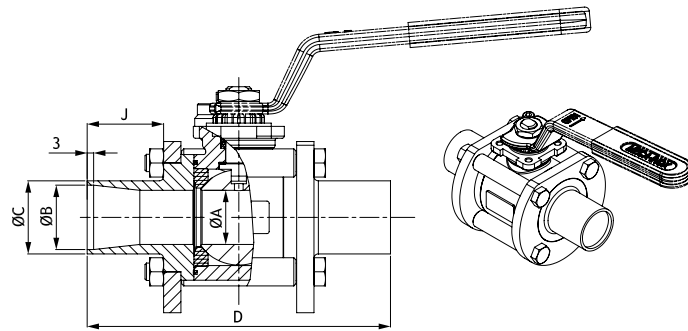

Sur demande : autres dimensions

DN Size	PN	ØA	ØB	ØC	D	J	
08	1/4"	100	11.1	10.3	13.5	113	35
12	3/8"	100	11.1	14	17.2	113	35
15	1/2"	100	14	18.1	21.3	117	35
20	3/4"	100	19	23.7	26.9	130	35
25	1"	70	25	29.7	33.7	140	35
32	1 1/4"	70	32	38.4	42.4	151	35
40	1 1/2"	50	38	44.3	48.3	159	35
50	2"	50	50	56.3	60.3	185	35

Soudure orbitale

DN 65 à 150
Passage intégral
Tube ISO

Orbital welding

Size 2 1/2" to 6"
Full bore
ISO pipe

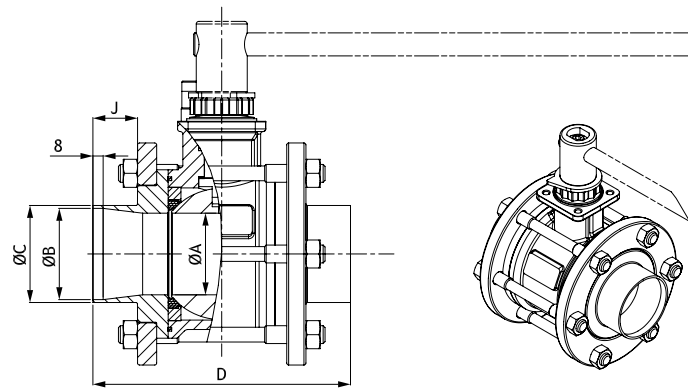

On request : other sizes available

DN Size	PN	ØA	ØB	ØC	D	J	
65	2 1/2"	40	64	70.3	76.1	202	35
80	3"	40	76	83.1	88.9	228	35
100	4"	25	100	107.9	114.3	256	35
125	5"	25	125	133.7	139.7	291	35
150	6"	16	150	162.3	168.3	323	35

RACCORDEMENTS
TYPE OF CONNECTIONS

Autres normes de tube

DN 08 à 200

A souder en bout - BW
Butt weld - BW

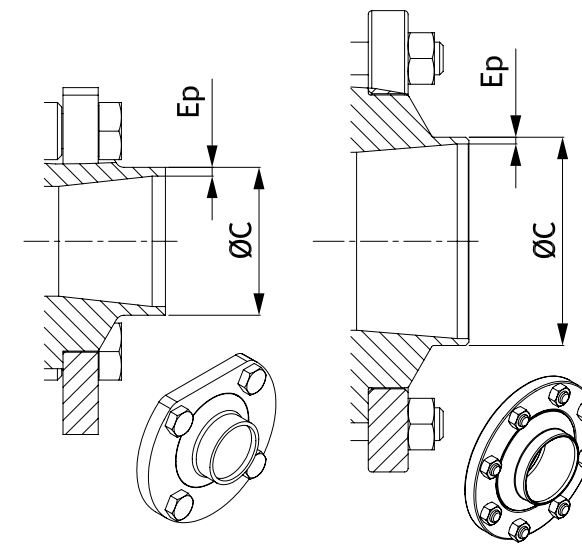

Other pipe standards

Size 1/4" to 8"

A soudure orbitale - O4
Orbital welding - O4

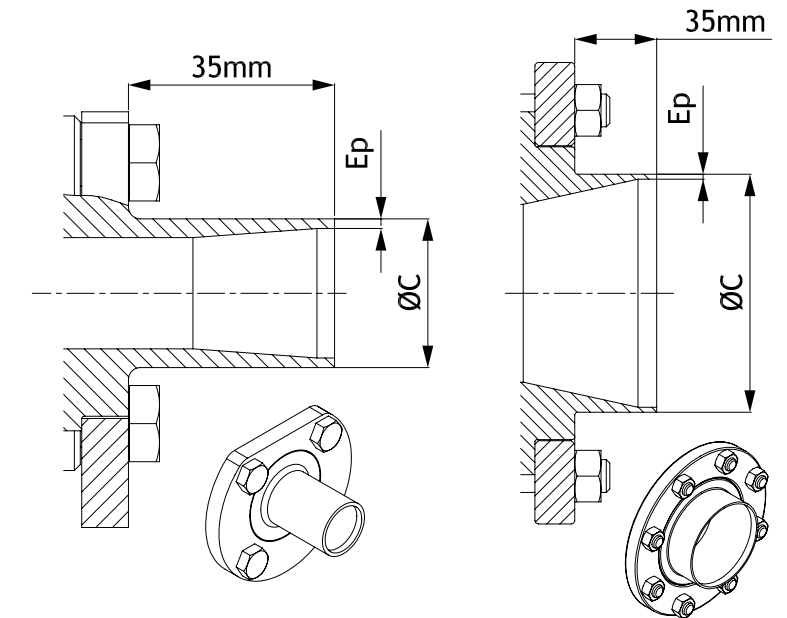

DN Size	DN															
	8		12		15		20		25		32		40		50	
	Ø ext	Ep	Ø ext	Ep	Ø ext	Ep	Ø ext	Ep	Ø ext	Ep	Ø ext	Ep	Ø ext	Ep	Ø ext	Ep
Métrique	10	1	12	1	18	1	23	1	28	1.5	34	2	44	2	54	2
SMS 3008	10	1	12	1	18	1	23	1	25	1.2	33.7	1.2	38	1.2	51	1.2
DIN 11850 R2	-	-	13	1.5	19	1.5	23	1.5	29	1.5	35	1.5	41	1.5	53	1.5
Schedule 10S	13.72	1.65	17.15	1.65	21.34	2.11	26.67	2.11	33.4	2.77	42.16	2.77	48.26	2.77	60.33	2.77
Schedule 40S	13.72	2.24	17.15	2.31	21.34	2.77	26.67	2.87	33.4	3.38	42.16	3.56	48.26	3.68	60.33	3.91
BSOD	6.35	1.65	9.52	1.65	12.7	1.65	19.05	1.65	25.4	1.65	31.75	1.65	38.1	1.65	50.8	1.65

DN Size	DN													
	65		80		100		125		150		200			
	Ø ext	Ep	Ø ext	Ep	Ø ext	Ep	Ø ext	Ep	Ø ext	Ep	Ø ext	Ep		
Métrique	68	1.5	83	1.5	104	2	129	2	154	2	204	2		
SMS 3008	63.5	1.6	76.1	1.6	101.6	2	-	-	-	-	-	-		
DIN 11850 R2	70	2	85	2	104	2	129	2	154	2	-	-		
Schedule 10S	73.03	3.05	88.9	3.05	114.3	3.05	141.3	3.4	168.28	3.4	219.08	3.76		
Schedule 40S	73.03	5.15	88.9	5.49	114.3	6.02	141.3	6.55	168.28	7.11	219.08	8.18		
BSOD	63.5	1.65	76.2	1.65	101.6	2.1	-	-	-	-	-	-		

RACCORDEMENTS
TYPE OF CONNECTIONS

A brides

DN 15 à 65
Passage Standard - PN 40

Flanged

Size 1/2" to 2 1/2"
Reduced bore - PN40

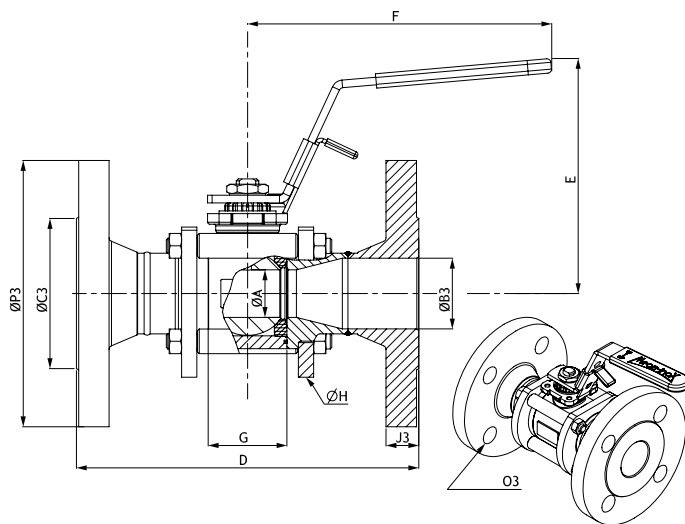

A brides

DN 15 à 50
Passage intégral - PN 40

Flanged

Size 1/2" to 2"
Full bore - PN40

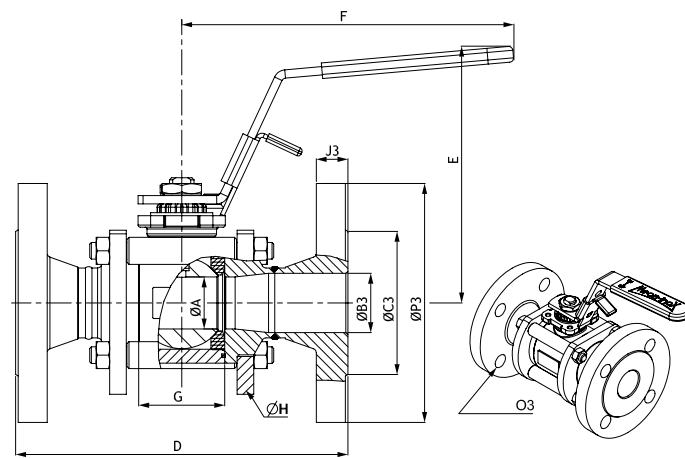

DN Size	PN	Ø A	Ø B3	Ø C3	D	E	F	G	Ø H	J3	O3	Ø P3	ISO 5211	Poids (Kg) Weight (Kg)	
V • Passage Standard / Reduced bore															
15	1/2"	40	11.1	17.3	45	130	123	120	20.4	56	16	4xØ14 / Ø65	95	F03	1.930
20	3/4"	40	14	22.3	58	150	126	120	24.4	63	18	4xØ14 / Ø75	105	F03	2.690
25	1"	40	19	28.5	68	160	145	160	31.6	80	18	4xØ14 / Ø85	115	F04	3.910
32	1 1/4"	40	25	37.2	78	180	149	160	41.4	88	18	4xØ18 / Ø100	140	F04	5.490
40	1 1/2"	40	32	43.1	88	200	160	190	48.2	104	18	4xØ18 / Ø110	150	F05	7.120
50	2"	40	38	54.5	102	230	165	190	56.2	117	20	4xØ18 / Ø125	165	F05	9.440
65	2 1/2"	40	50	70.3	122	290	180	230	71	148	22	8xØ18 / Ø145	185	F07	15.370
N • Passage intégral / Full bore															
15	1/2"	40	14	17.3	45	130	126	120	24.4	63	16	4xØ14 / Ø65	95	F03	2.250
20	3/4"	40	19	22.3	58	150	145	160	31.6	80	18	4xØ14 / Ø75	105	F04	3.470
25	1"	40	25	28.5	68	160	149	160	41.4	88	18	4xØ14 / Ø85	115	F04	4.330
32	1 1/4"	40	32	37.2	78	180	160	190	48.2	104	18	4xØ18 / Ø100	140	F05	6.880
40	1 1/2"	40	38	43.1	88	200	165	190	56.2	117	18	4xØ18 / Ø110	150	F05	8.080
50	2"	40	50	54.5	102	230	180	230	71	148	20	4xØ18 / Ø125	165	F07	13.890

RACCORDEMENTS
TYPE OF CONNECTIONS

A brides

DN 80 à 200
Passage Standard

Flanged

Size 3" to 8"
Reduced bore

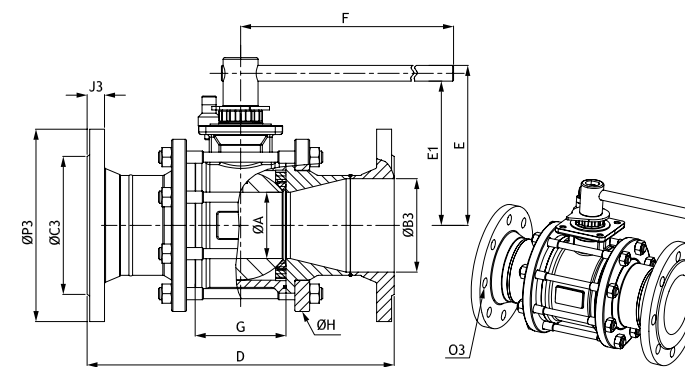

A brides

DN 65 à 150
Passage intégral

Flanged

Size 2 1/2" to 6"
Full bore

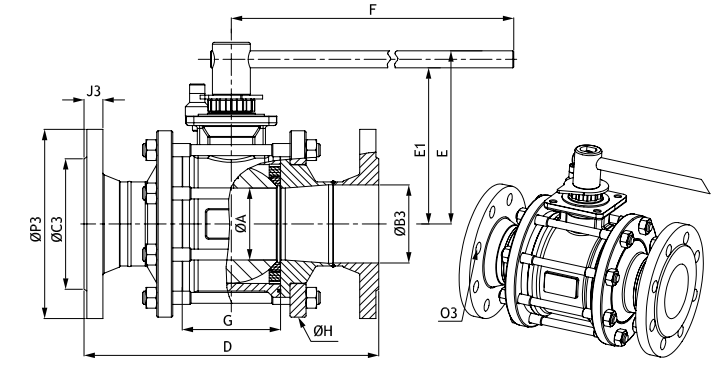

DN Size	PN	Ø A	Ø B	Ø C3	D	E	E1	F	G	Ø H	J3	O3	P3	ISO 5211	Poids (Kg) Weight (Kg)	
V • Passage Standard / Reduced bore																
80	3"	40	64	82.5	138	310	171	153	370	84	174	24	8xØ18 / Ø160	200	F07	22.920
100	4"	16	76	107.1	162	350	182	165	440	104	197	24	8xØ22 / Ø190	235	F10	39.520
125	5"	16	100	131.7	188	400	204	184	505	130	236	22	8xØ18 / Ø210	250	F10	48.720
150	6"	16	125	159.3	212	480	248	221	710	155	288	22	8xØ22 / Ø240	285	F12	79.450
200	8"	16	150	207.3	268	600	270	243	710	183	324	24	12xØ22 / Ø295	340	F12	120.810
N • Passage intégral / Full bore																
65	2 1/2"	40	64	70.3	122	290	171	153	370	84	174	22	8xØ18 / Ø145	185	F07	20.840
80	3"	40	76	82.5	138	310	182	165	440	104	197	24	8xØ18 / Ø160	200	F10	30.150
100	4"	16	100	107.1	162	350	204	184	505	130	236	24	8xØ22 / Ø190	235	F10	43.840
125	5"	16	125	131.7	188	400	248	221	710	155	288	22	8xØ18 / Ø210	250	F12	72.210
150	6"	16	150	159.3	212	480	270	243	710	183	324	22	8xØ22 / Ø240	285	F12	100.850

3 VOIES
3-WAY

Version 3 voies / Entrée Horizontale
Passage intégral et Standard

3VLH

Passage en L
Distribution du fluide

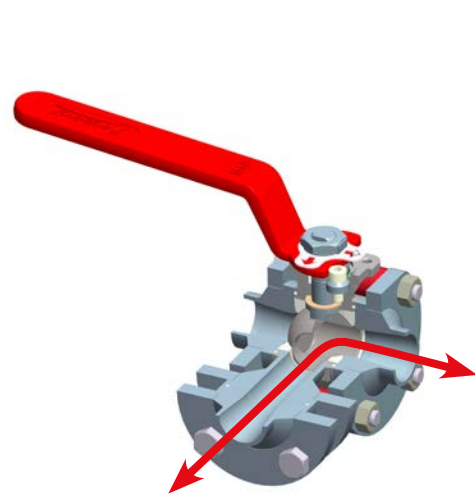

3-way version / Horizontal inlet
Full bore & reduced bore

3VLH

L port
Diverting flow

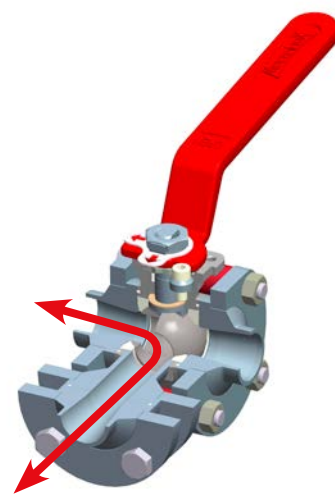

3VTH

Passage en T
Distribution du fluide ou mélange

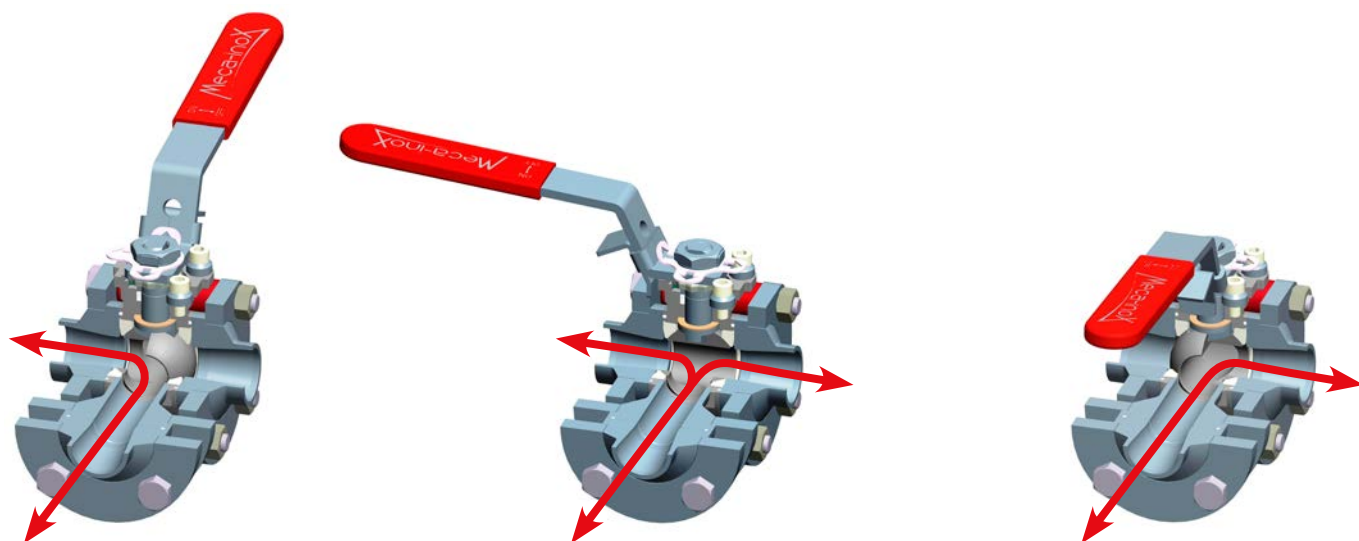

3VTH

T port
Diverting flow or mixing

3 VOIES
3-WAY

Version 3 voies / Entrée Verticale
Passage intégral et Standard

3VLV

Passage en L
Distribution ou blocage du fluide

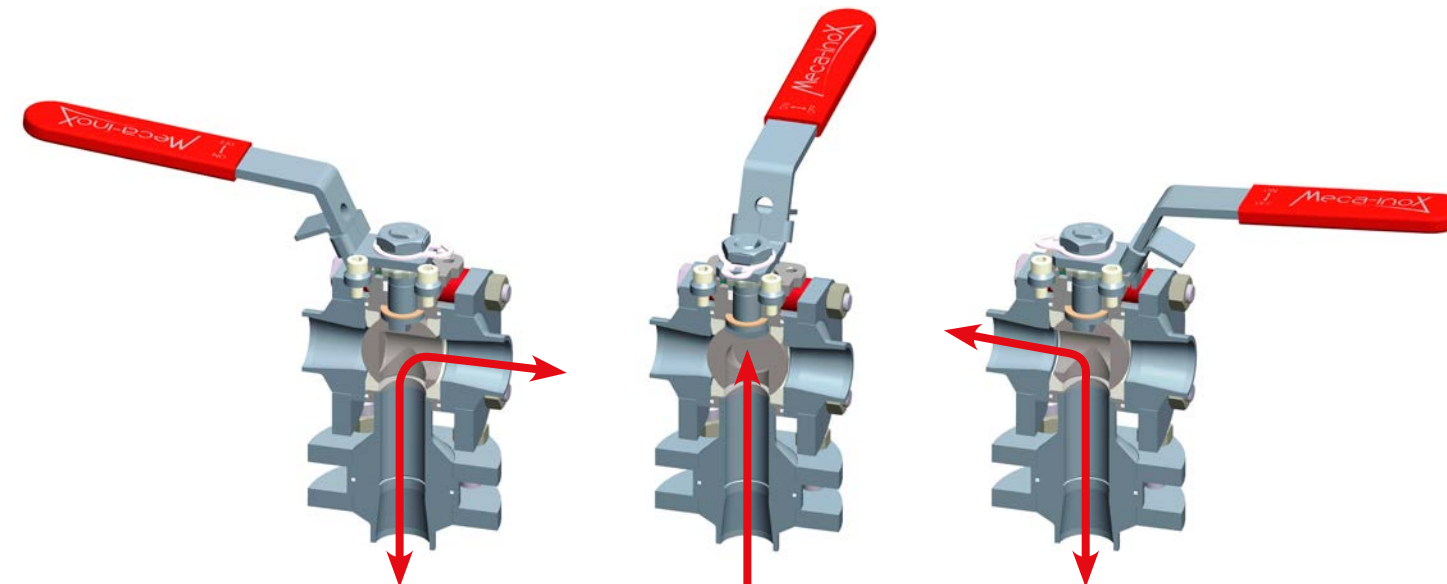

3-way version / Vertical inlet
Full bore & reduced bore

3VLV

L port
Diverting flow or flow stop

Dimensions entrée Horizontale & Verticale Horizontal & Vertical inlet size

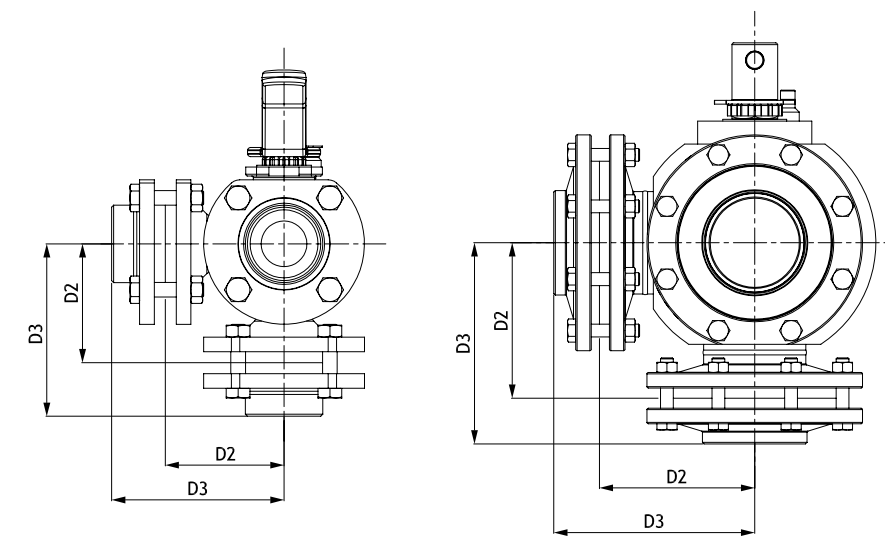

DN Size	08 1/4"	12 3/8"	15 1/2"	20 3/4"	25 1"	32 1 1/4"	40 1 1/2"	50 2"	65 2 1/2"	80 3"	100 4"
D2	45	45	50	60	65	72	80	103	135	149	170
D3	67.3	67.3	72.8	86.7	94.3	102.9	114.4	142.5	183	202	220

MOTORISATION PNEUMATIQUE
PNEUMATIC ACTUATION

Nomenclature PS4 Motorisée

DN 08 à 50

PS4 actuated components

Size 1/4" to 2"

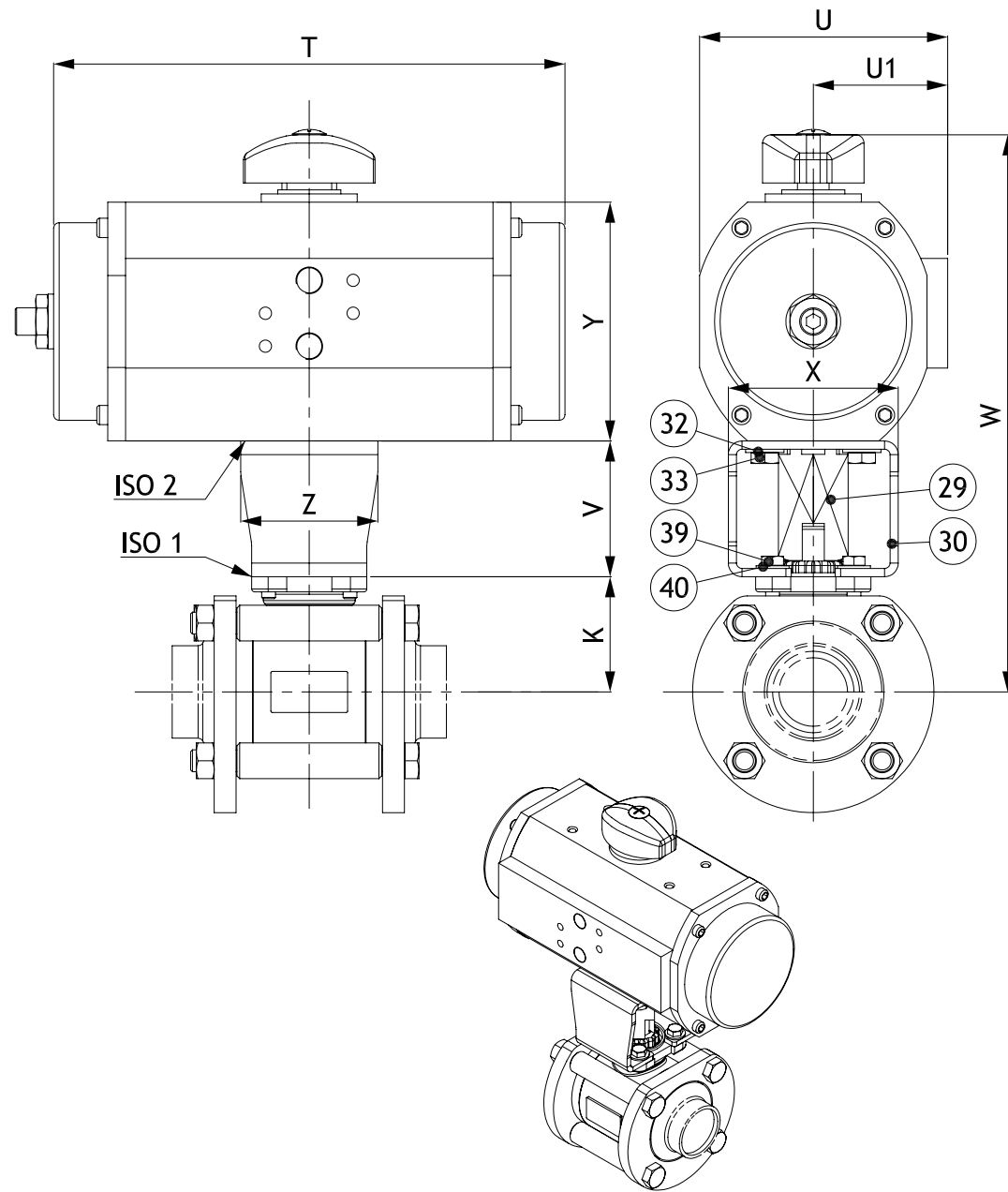

DN 08 à 50

N°	Nb	Description	Matière (EN)
29	1	Entraîneur	1.4307
30	1	Arcade	1.4307
32	4	Rondelle plate coté actionneur	1.4301
33	4	Vis TH coté actionneur	1.4301
39	4	Vis TH coté robinet	1.4301
40	4	Rondelle plate coté robinet	1.4301

Size 1/4" to 2"

Item	Qty	Description	Material (ASTM)
29	1	Coupling	304L
30	1	Bracket	304L
32	4	Ring (actuator side)	304
33	4	Screw (actuator side)	304
39	4	Screw (valve side)	304
40	4	Ring (valve side)	304

MOTORISATION PNEUMATIQUE
PNEUMATIC ACTUATION

PS4 Motorisée

DN 10 à 50

PS4 actuated

Size 1/4" to 2"

Modèle TRUTORQ Simple Effet sur PS4 Spring Return TRUTORQ type on PS4

DN - Size		K	ISO 1	TRUTORQ	ISO 2	T	U	U1	V	W	X	Y	Z		
Nominal Full	Standard Reduced														
10	1/4"-3/8"	15	1/2"	27.5	F03	TSR003	F04	149.5	69.5	38	47	164.5	52	70	36
15	1/2"	20	3/4"	31	F03	TSR003	F04	149.5	69.5	38	47	168	52	70	42
20	3/4"	25	1"	37.9	F04	TSR005	F05	186.5	90.5	49	49.5	194.4	52	87	42
25	1"	32	1"1/4"	42	F04	TSR005	F05	186.5	90.5	49	49.5	198.5	62	87	50
32	1"1/4"	40	1"1/2"	54	F05	TSR005	F05	186.5	90.5	49	49.5	210.5	62	87	50
40	1"1/2"	50	2"	59	F05	TSR005	F05	186.5	90.5	49	49.5	215.5	62	87	50
50	2"	65	2"1/2"	73	F07	TSR008	F05	162	105	57	79.5	281.5	85	109	69

Données pour pression de service à : ΔP 7 bars max. et 6 bars d'air comprimé / Values given for service pressure at: ΔP 7 bars max. and 6 bars air supply.

Modèle TRUTORQ Double Effet sur PS4 Double Acting TRUTORQ type on PS4

DN - Size		K	ISO 1	TRUTORQ	ISO 2	T	U	U1	V	W	X	Y	Z		
Nominal Full	Standard Reduced														
10	1/4"-3/8"	15	1/2"	27.5	F03	TDA003	F04	149.5	69.5	38	47	164.5	52	70	36
15	1/2"	20	3/4"	31	F03	TDA003	F04	149.5	69.5	38	47	168	52	70	36
20	3/4"	25	1"	37.9	F04	TDA003	F04	149.5	69.5	38	49.5	177.4	52	70	42
25	1"	32	1"1/4"	42	F04	TDA003	F04	149.5	69.5	38	49.5	181.5	52	70	42
32	1"1/4"	40	1"1/2"	54	F05	TDA003	F04	149.5	69.5	38	49.5	193.5	52	70	42
40	1"1/2"	50	2"	59	F05	TDA003	F04	149.5	69.5	38	49.5	198.5	52	70	42
50	2"	65	2"1/2"	73	F07	TDA005	F05	186.5	90.5	49	79.5	259.5	85	87	69

Données pour pression de service à : ΔP 7 bars max. et 6 bars d'air comprimé / Values given for service pressure at: ΔP 7 bars max. and 6 bars air supply.

PS4 ΔP: 7 bars

DN	Air Moteur (Bar)	Double Effet Double acting Code	Simple Effet Spring return Code
10 (08-12) F03	6	KPNI410 0411 2TDA003	KPNI410 0411 2TSR003 N66
15 F03	6	KPNI410 0411 2TDA003	KPNI410 0411 2TSR003 N66
20 F04	6	KPNI420 0411 2TDA003	KPNI420 0514 2TSR005 N66
25 F04	6	KPNI420 0411 2TDA003	KPNI420 0514 2TSR005 N66
32 F05	6	KPNI432 0411 2TDA003	KPNI432 0514 2TSR005 N66
40 F05	6	KPNI432 0411 2TDA003	KPNI432 0514 2TSR005 N66
50 F07	6	KPNI450 0514 2TDA005	KPNI450 0514 2TSR008 N44

PZ4 Motorisée

DN 10 à 50

PZ4 actuated

Size 1 / 4" to 2"

Modèle TRUTORQ Simple Effet sur PZ4 *Single Acting TRUTORQ type on PZ4*

DN - Size		K	ISO 1	TRUTORQ	ISO 2	T	U	U1	V	W	X	Y	Z
Nominal Full	Standard Reduced												
10	1/4"-3/8"	15	F03	TSR003	F04	149.5	69.5	38	47	164.5	52	70	36
15	1/2"	20	F03	TSR005	F05	186.5	90.5	49	47	185	52	87	42
20	3/4"	25	F04	TSR005	F05	186.5	90.5	49	49.5	194.4	52	87	42
25	1"	32	F04	TSR005	F05	186.5	90.5	49	49.5	198.5	62	87	50
32	1 1/4"	40	F05	TSR005	F05	186.5	90.5	49	49.5	210.5	62	87	50
40	1 1/2"	50	F05	TSR005	F05	186.5	90.5	49	49.5	215.5	62	87	50
50	2"	65	F07	TSR012	F07	194	121	67	79.5	291	85	118.5	69

Données pour pression de service à : ΔP 7 bars max. et 6 bars d'air comprimé / Values given for service pressure at: ΔP 7 bars max. and 6 bars air supply.

Modèle TRUTORQ Double Effet sur PZ4 *Double Acting TRUTORQ type on PZ4*

DN - Size		K	ISO 1	TRUTORQ	ISO 2	T	U	U1	V	W	X	Y	Z
Nominal Full	Standard Reduced												
10	1/4"-3/8"	15	F03	TDA003	F04	149.5	69.5	38	47	164.5	52	70	36
15	1/2"	20	F03	TDA003	F04	149.5	69.5	38	47	168	52	70	36
20	3/4"	25	F04	TDA003	F04	149.5	69.5	38	49.5	177.4	52	70	42
25	1"	32	F04	TDA003	F04	149.5	69.5	38	49.5	181.5	52	70	42
32	1 1/4"	40	F05	TDA003	F04	149.5	69.5	38	49.5	193.5	52	70	42
40	1 1/2"	50	F05	TDA003	F04	149.5	69.5	38	49.5	198.5	52	70	42
50	2"	65	F07	TDA005	F05	186.5	90.5	49	79.5	259.5	85	87	69

Données pour pression de service à : ΔP 7 bars max. et 6 bars d'air comprimé / Values given for service pressure at: ΔP 7 bars max. and 6 bars air supply.

PZ4 Δ P : 7 bars

DN	Air Moteur (Bar)	Double Effet Double acting Code	Simple Effet Spring return Code
10 (08-12) F03	6	KPNI410 0411 2TDA003	KPNI410 0411 2TSR003 N66
15 F03	6	KPNI410 0514 2TDA003	KPNI410 0514 2TSR005 N66
20 F04	6	KPNI420 0411 2TDA003	KPNI420 0514 2TSR005 N66
25 F04	6	KPNI420 0411 2TDA003	KPNI420 0514 2TSR005 N66
32 F05	6	KPNI432 0411 2TDA003	KPNI432 0514 2TSR005 N66
40 F05	6	KPNI432 0411 2TDA003	KPNI432 0514 2TSR005 N66
50 F07	6	KPNI450 0514 2TDA005	KPNI450 0717 2TSR012 N44

PY4 Motorisée

DN 10 à 50

PY4 actuated

Size 1 / 4" to 2"

Modèle TRUTORQ Simple Effet sur PY4 *Spring Return TRUTORQ type on PY4*

DN - Size		K	ISO 1	TRUTORQ	ISO 2	T	U	U1	V	W	X	Y	Z
Nominal Full	Standard Reduced												
10	1/4"-3/8"	15	F03	2TSR003	F04	149.5	69.5	38	47	164.5	52	70	42
15	1/2"	20	F03	2TSR005	F05	186.5	90.5	49	47	185	62	87	50
20	3/4"	25	F04	2TSR005	F05	162	105	57	49.5	216.4	62	109	50
25	1"	32	F04	2TSR008	F07	194	121	67	49.5	230	82	118.5	69
32	1 1/4"	40	F05	2TSR020	F07	218	136.5	72	49.5	264	82	140.5	69
40	1 1/2"	50	F05	2TSR020	F10	218	136.5	72	49.5	269	82	140.5	69
50	2"	65	F07	2TSR035	F10	266	156	78	79.5	339	120	166.5	105

Données pour température de service cryogénique (-196°C) et 6 bars d'air comprimé à : ΔP 40 bars Max (DN 10 à 32), ΔP 20 bars Max (DN40 à 50)
Values given for cryogenics service (-196°C) and 6 bars air supply pressure at: ΔP 40 bars Max (DN 10 to 32), ΔP 20 bars Max (DN40 to 50)

Modèle TRUTORQ Double Effet sur PY4 *Double Acting TRUTORQ type on PY4*

DN - Size		K	ISO 1	TRUTORQ	ISO 2	T	U	U1	V	W	X	Y	Z
Nominal Full	Standard Reduced												
10	1/4"-3/8"	15	F03	2TDA003	F04	14.95	69.5	38	47	164.5	52	70	42
15	1/2"	20	F03	2TDA003	F04	149.5	69.5	38	47	168	52	70	42
20	3/4"	25	F04	2TDA003	F04	149.5	69.5	38	49.5	177.4	62	70	50
25	1"	32	F04	2TDA005	F05	186.5	90.5	49	49.5	198.5	62	87	50
32	1 1/4"	40	F05	2TDA005	F05	186.5	90.5	49	49.5	210.5	62	87	50
40	1 1/2"	50	F05	2TDA008	F05	162	105	57	49.5	237.5	62	109	50
50	2"	65	F07	2TDA012	F07	194	121	67	79.5	291	85	118.5	69

Données pour température de service cryogénique (-196°C) et 6 bars d'air comprimé à : ΔP 40 bars Max (DN 10 à 32), ΔP 20 bars Max (DN40 à 50)
Values given for cryogenics service (-196°C) and 6 bars air supply pressure at: ΔP 40 bars Max (DN 10 to 32), ΔP 20 bars Max (DN40 to 50)

PY4 Δ P : 40 bars (DN 10 - 32), 20 bars (DN 40- 50)

DN	Air Moteur (Bar)	Double Effet Double acting Code	Simple Effet Spring return Code
10 F03	6	KPNI410 0411 2TDA003	KPNI410 0411 2TSR003 N66
15 F03	6	KPNI410 0411 2TDA003	KPNI410 0514 2TSR005 N66
20 F04	6	KPNI420 0411 2TDA003	KPNI420 0514 2TSR005 N66
25 F04	6	KPNI420 0514 2TDA005	KPNI420 0514 2TSR008 N44
32 F05	6	KPNI432 0514 2TDA005	KPNI432 0717 2TSR020 N44
40 F05	6	KPNI432 0514 2TDA008	KPNI432 0717 2TSR020 N44
50 F07	6	KPNI450 0717 2TDA012	KPNI450 1022 2TSR035 N44

Nomenclature PS4 Motorisée

DN 65 à 150

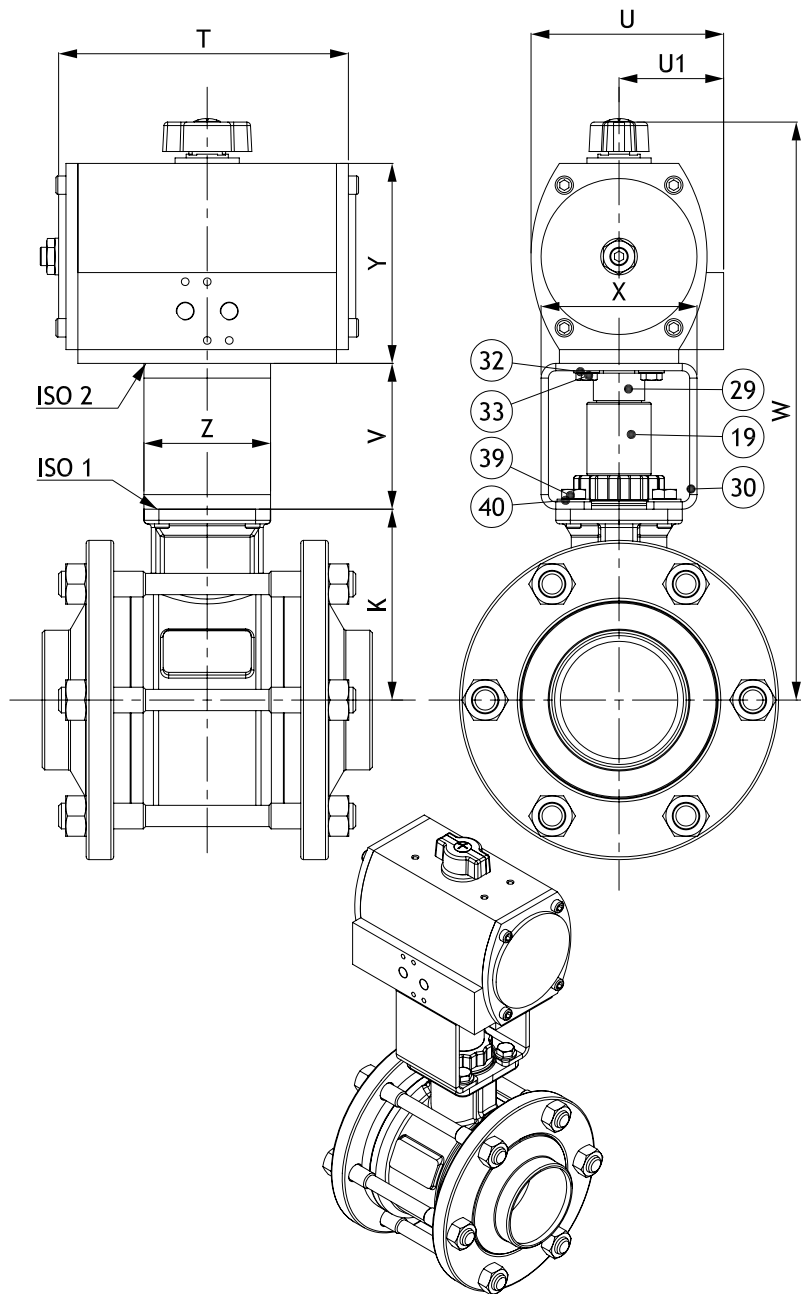

PS4 actuated components

Size 2"1/2 to 6"

DN 65 à 150

N°	Nb	Description	Matière (EN)
19	1	Noix de manœuvre	1.4305
29	1	Entraîneur	1.4307
30	1	Arcade	1.4307
32	4	Rondelle plate coté actionneur	1.4301
33	4	Vis TH coté actionneur	1.4301
39	4	Vis TH coté robinet	1.4301
40	4	Rondelle plate coté robinet	1.4301

Size 2"1/2 to 6"

Item	Qty	Description	Material (ASTM)
19	1	Handle adaptator	303
29	1	Coupling	304L
30	1	Bracket	304L
32	4	Ring (actuator side)	304
33	4	Screw (actuator side)	304
39	4	Screw (valve side)	304
40	4	Ring (valve side)	304

PS4 Motorisée

DN 65 à 150

PS4 actuated

Size 2"1 /2 to 6"

Modèle TRUTORQ Simple Effet sur PS4 *Spring Return TRUTORQ type on PS4*

DN - Size		K	ISO 1	TRUTORQ	ISO 2	T	U	U1	V	W	X	Y	Z		
Nominal Full	Standard Reduced														
65	2"1/2	80	3"	104	F07	TSR035	F10	266	156	78	79.5	370	120	166.5	105
80	3"	100	4"	114	F10	TSR035	F10	266	156	78	79.5	380	120	166.5	95
100	4"	125	5"	133	F10	TSR055	F12	312	191	95.5	79.5	450	136	207.5	118
125	5"	150	6"	161	F12	TSR055	F12	312	191	95.5	99.5	498	144	207.5	118
150	6"	200	8"	180	F12	TSR100	F14	361	227	113.5	99.5	559.5	158	250	140

Données pour pression de service à : ΔP 7 bars max. et 6 bars d'air comprimé / Values given for service pressure at: ΔP 7 bars max. and 6 bars air supply.

Modèle TRUTORQ Double Effet sur PS4 *Double Acting TRUTORQ type on PS4*

DN - Size		K	ISO 1	TRUTORQ	ISO 2	T	U	U1	V	W	X	Y	Z		
Nominal Full	Standard Reduced														
65	2"1/2	80	3"	104	F07	TDA008	F07	162	105	57	79.5	312.5	85	109	69
80	3"	100	4"	114	F10	TDA012	F07	194	121	67	79.5	332	120	118.5	105
100	4"	125	5"	133	F10	TDA020	F07	218	136.5	72	79.5	373	120	140.5	105
125	5"	150	6"	161	F12	TDA020	F07	218	136.5	72	99.5	421	136	140.5	118
150	6"	200	8"	180	F12	TDA035	F10	266	156	78	99.5	466	144	166.5	118

Données pour pression de service à : ΔP 7 bars max. et 6 bars d'air comprimé / Values given for service pressure at: ΔP 7 bars max. and 6 bars air supply.

PS4 ΔP: 7 bars

DN	Air Moteur (Bar)	Double Effet Double acting Code	Simple Effet Spring return Code
65 F07	6	KPNI2P065 0714 2TDA008	KPNI2P065 1022 2TSR035 N44
80 F10	6	KPNI2P080 0717 2TDA012	KPNI2P080 1022 2TSR035 N44
100 F10	6	KPNI2P100 0717 2TDA020	KPNI2P100 1227 2TSR055 N44
125 F12	6	KPNI2P125 0717 2TDA020	KPNI2P125 1227 2TSR055 N44
150 F12	6	KPNI2P125 1022 2TDA035	KPNI2P125 1436 2TSR100 N44

PZ4 Motorisée

DN 65 à 150

PZ4 actuated

Size 2"1/2 to 6"

Modèle TRUTORQ Simple Effet sur PZ4 *Single Acting TRUTORQ type on PZ4*

DN - Size				K	ISO 1	TRUTORQ	ISO 2	T	U	U1	V	W	X	Y	Z
Nominal Full	Standard Reduced														
65	2"1/2	80	3"	104	F07	TSR035	F10	266	156	78	79.5	370	120	166.5	105
80	3"	100	4"	114	F10	TSR035	F10	266	156	78	79.5	380	120	166.5	95
100	4"	125	5"	133	F10	TSR055	F12	312	191	95.5	79.5	450	136	207.5	118
125	5"	150	6"	161	F12	TSR055	F12	312	191	95.5	99.5	498	144	207.5	118
150	6"	200	8"	180	F12	TSR100	F14	361	227	113.5	99.5	559.5	158	250	140

Données pour pression de service à : ΔP 7 bars max. et 6 bars d'air comprimé / Values given for service pressure at: ΔP 7 bars max. and 6 bars air supply.

Modèle TRUTORQ Double Effet sur PZ4 *Double Acting TRUTORQ type on PZ4*

DN - Size				K	ISO 1	TRUTORQ	ISO 2	T	U	U1	V	W	X	Y	Z
Nominal Full	Standard Reduced														
65	2"1/2	80	3"	104	F07	TDA008	F07	162	105	57	79.5	312.5	85	109	69
80	3"	100	4"	114	F10	TDA012	F07	194	121	67	79.5	332	120	118.5	105
100	4"	125	5"	133	F10	TDA020	F07	218	136.5	72	79.5	373	120	140.5	105
125	5"	150	6"	161	F12	TDA020	F07	218	136.5	72	99.5	421	136	140.5	118
150	6"	200	8"	180	F12	TDA055	F12	312	191	95.5	99.5	517	144	207.5	118

Données pour pression de service à : ΔP 7 bars max. et 6 bars d'air comprimé / Values given for service pressure at: ΔP 7 bars max. and 6 bars air supply.

PZ4 ΔP: 7 bars

DN	Air Moteur (Bar)	Double Effet Double acting Code	Simple Effet Spring return Code
65 F07	6	KPNI2P065 0714 2TDA008	KPNI2P065 1022 2TSR035 N44
80 F10	6	KPNI2P080 0717 2TDA012	KPNI2P080 1022 2TSR035 N44
100 F10	6	KPNI2P100 0717 2TDA020	KPNI2P100 1227 2TSR055 N44
125 F12	6	KPNI2P125 0717 2TDA020	KPNI2P125 1227 2TSR055 N44
150 F12	6	KPNI2P125 1227 2TDA055	KPNI2P125 1436 2TSR100 N44

PY4 Motorisée

DN 65 à 100

PY4 actuated

Size 2"1/2 to 4"

Modèle TRUTORQ Simple Effet sur PY4 *Spring Return TRUTORQ type on PY4*

DN - Size				K	ISO 1	TRUTORQ	ISO 2	ISO 3	T	U	U1	V	W	X	Y	Z
Nominal Full	Standard Reduced															
65	2"1/2	80	3"	104	F07	2TSR055	F07	F12	312	191	95.5	79.5	411	132	207.5	120
80	3"	100	4"	114	F10	2TSR055	F10	F12	312	191	95.5	79.5	421	136	207.5	118
100	4"	125	5"	133	F10	2TSR100	F10	F14	361	227	113.5	79.5	482.5	158	250	140

Données pour température de service cryogénique (-196 °C) et 6 bars d'air comprimé à : ΔP 10 bars Max (DN 65 à 100)
Values given for cryogenics service (-196°C) and 6 bars air supply pressure at: ΔP 10 bars Max (DN 65 to 100)

Modèle TRUTORQ Double Effet sur PY4 *Double Acting TRUTORQ type on PY4*

DN - Size				K	ISO 1	TRUTORQ	ISO 2	ISO 3	T	U	U1	V	W	X	Y	Z
Nominal Full	Standard Reduced															
65	2"1/2	80	3"	104	F07	2TDA020	F07	F07	218	136.5	72	79.5	344	85	140.5	69
80	3"	100	4"	114	F10	2TDA020	F10	F07	218	136.5	72	79.5	354	85	140.5	69
100	4"	125	5"	133	F10	2TDA035	F10	F10	266	156	78	79.5	399	120	166.5	95

Données pour température de service cryogénique (-196 °C) et 6 bars d'air comprimé à : ΔP 10 bars Max (DN 65 à 100)
Values given for cryogenics service (-196°C) and 6 bars air supply pressure at: ΔP 10 bars Max (DN 65 to 100)

PY4 ΔP: 10 bars (DN65 - 100)

DN - Size				Air Moteur (Bar)	Double Effet Double acting Code	Simple Effet Spring return Code
Nominal Full	Standard Reduced					
65 F07	2"1/2	80 F07	3"	6	KPNI2P065 0717 2TDA020	KPNI2P065 1227 2TSR055 N44
80 F10	3"	100 F10	4"	6	KPNI2P080 0717 2TDA020	KPNI2P080 1227 2TSR055 N44
100 F10	4"	125 F10	5"	6	KPNI2P100 1022 2TDA035	KPNI2P100 1436 2TSR100 N44

DN 08 à 100

PN 100 / PN 25
Passage Standard ou intégral
Brides tournantes
Platine ISO
Sécurité feu (option)



Série DN 08 à 50
Size 1/4" to 2"1/2 series

Size 1/4" to 4"

PN 10 / PN 25
Reduced or full bore
Rotating ends system
ISO top flange
Fire safe (option)



Série motorisée
Actuated series



Série 3 voies
3 ways series



Série bronze
Bronze series

**TYPES DE JOINTS
SEATS & SEALS MATERIAL**

Caractéristiques

PY4 CY et PY4 CY sécurité feu : Sièges TF 3215 (PTFE + Carbone). Plage de température -200 °C / +200 °C
Version avec rehausse pour applications avec prise en glace possible.

Versions inox 316L, 904L (UB6), 304L, Alloy 22.

Version standard :

Perçage boule dans la rainure pour décompression du corps en position ouverte. Perçage boule coté amont pour augmenter la décompression en position fermée.

PY4 CY : la rehausse crée un tampon gazeux qui évite la prise en glace de la tige et facilite la manœuvre du robinet.

Agréments :

EN1626 pour design PY4 CY

EN12567, ISO10497, API607 et API6FA pour design PY4 CY

Fire Safe

DESP 97/23/CE

TA-Luft (Conformité aux émanations fugitives)

AD2000 Merkblatt

Options:

ATEX 94/9/CE

Marquage π suivant la directive 2010/35/UE TPED :

certification ADR § 1.8.7.6

Technical data

PY4 CY and PY4 CY fire safe: TF 3215 seats (PTFE + Carbon). Temperature range: -200°C / +200°C

Version with extension for applications with icing risk.

316L, 904L, 304L, Alloy 22 version.

Standard version:

Ball drilling in the stem mark for cavity relief in the open position.

Upstream vent hole for cavity relief in the closed position.

PY4 CY: Stem extension avoids any stem freezing and allows easy valve operation.

Approvals:

PY4 CY design: EN1626

PY4 CY Fire Safe design: EN12567, ISO10497, API607 and API6FA

PED 97/23/CE

TA-Luft (fugitive emissions)

AD2000 Merkblatt

Options:

ATEX 94/9/CE

π marking according to 2010/35/UE TPED:

certification ADR §1.8.7.6

Courbes Pression/Température Pressure/Temperature diagrams

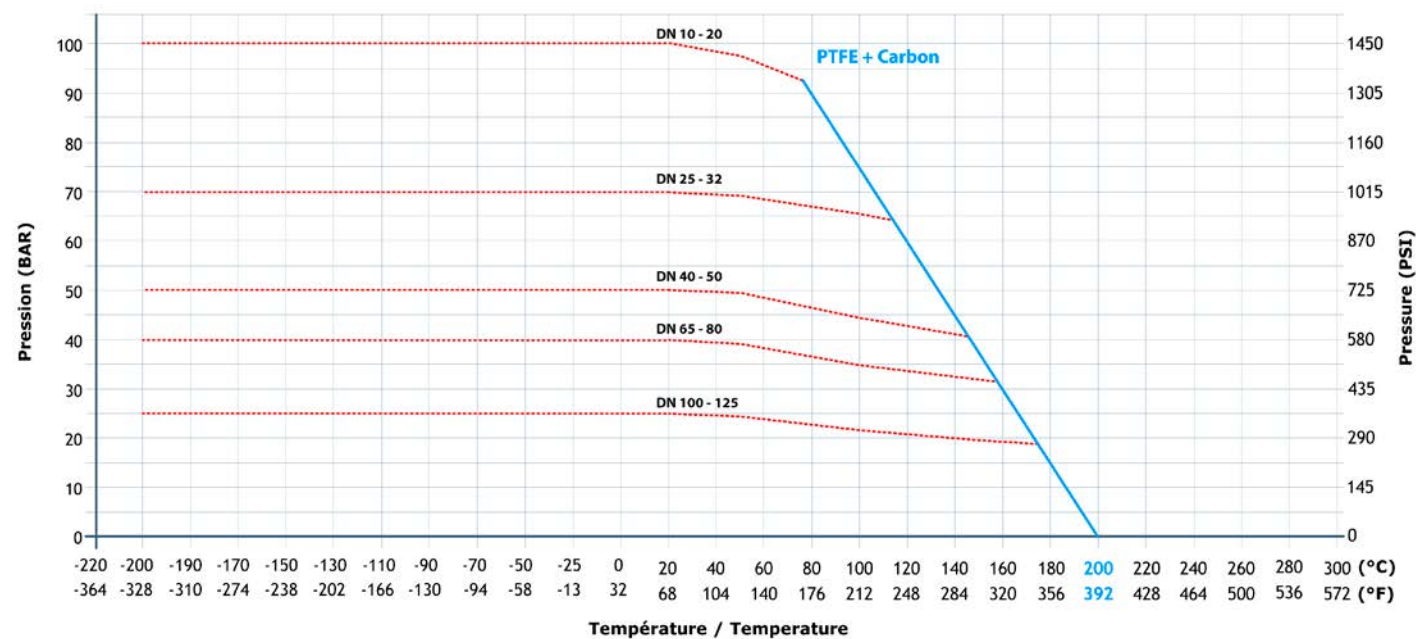

----- Tenue mécanique du corps
----- Tenue mécanique des sièges

Toutes les valeurs sont données pour passage intégral.

----- mechanical strength of body
----- mechanical strength of seats

All values are given for full bore size.

**NOMENCLATURE
COMPONENTS**

PY4 CY

DN 08 à 50

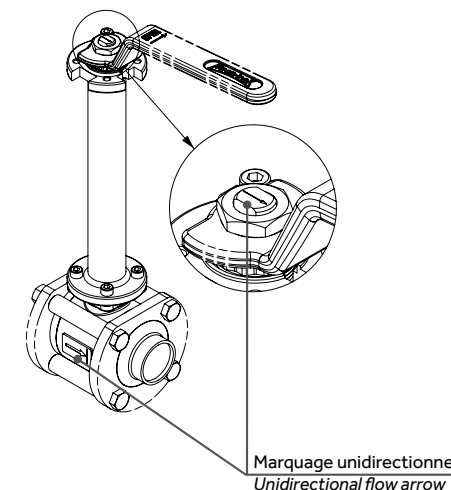

Sphère percée en amont
Upstream pressure relief hole

PY4 CY

Size 1/4" to 2"

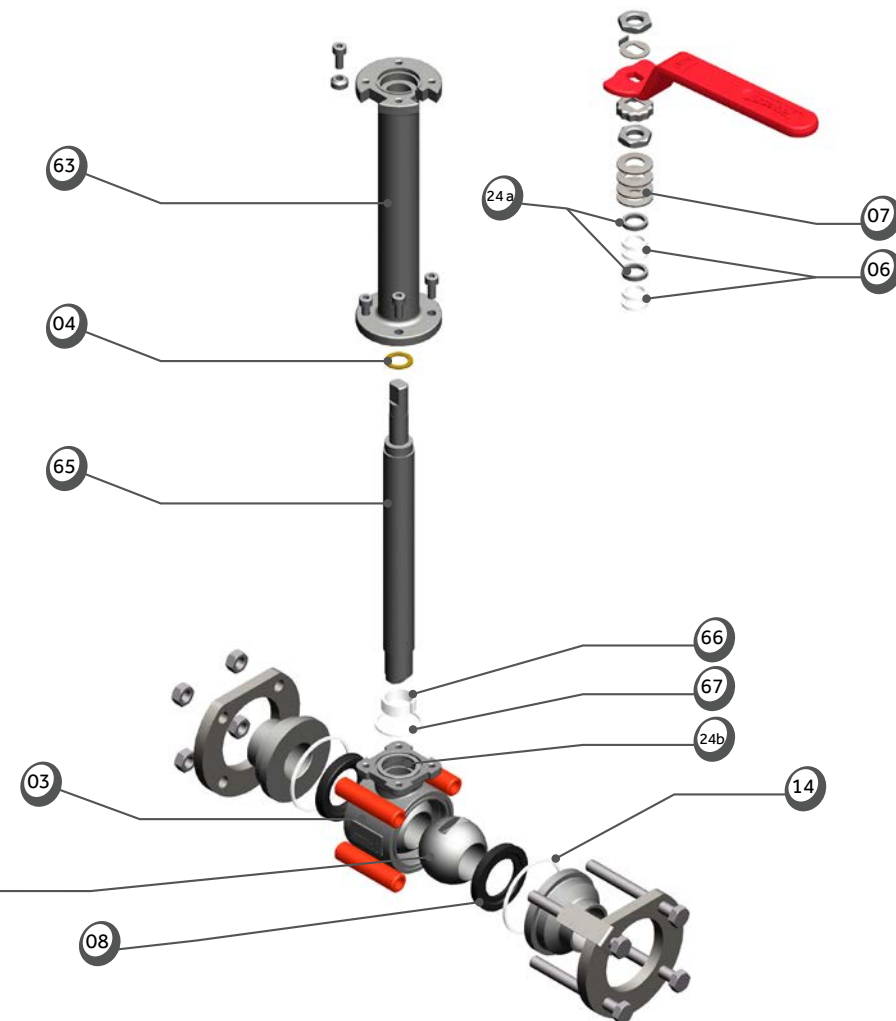

N°	Nb	Description	Matière (EN)
03	1	Corps	1.4409
04	1	Rondelle de friction	PTFE 20 % PEEK
06	2	Garniture de presse étoupe	PTFE 33 % C + 2 % Gr
07	4	Rondelle ressort	1.4310
08	2	Siège	PTFE+Carbone
14	2	Joints de corps	PTFE
24a	2	Fouloir	1.4404
24b	1	Bague de guidage	1.4404
63	1	Corps de rehausse	1.4307
65	1	Tige de rehausse	1.4404
66	1	Bague de guidage fendue	PTFE
67	1	Joint de platine coté robinet	PTFE

Item	Qty	Description	Material (ASTM)
03	1	Body	CF-3M
04	1	Stem thrust seal	20%PEEK PTFE
06	2	Gland packing	33%C+2%GrPTFE
07	4	Spring washers	301
08	2	Seat	PTFE+Carbon
14	2	Body seal	PTFE
24a	2	Gland	316L
24b	1	Guide ring	316L
63	1	Extension's body	304L
65	1	Extended stem	316L
66	1	Split ring	PTFE
67	1	Flat seal (valve)	PTFE

CRYO

**NOMENCLATURE
COMPONENTS**

PY4 CY

DN 65 à 100

PY4 CY

Size 2" 1/2 to 4"

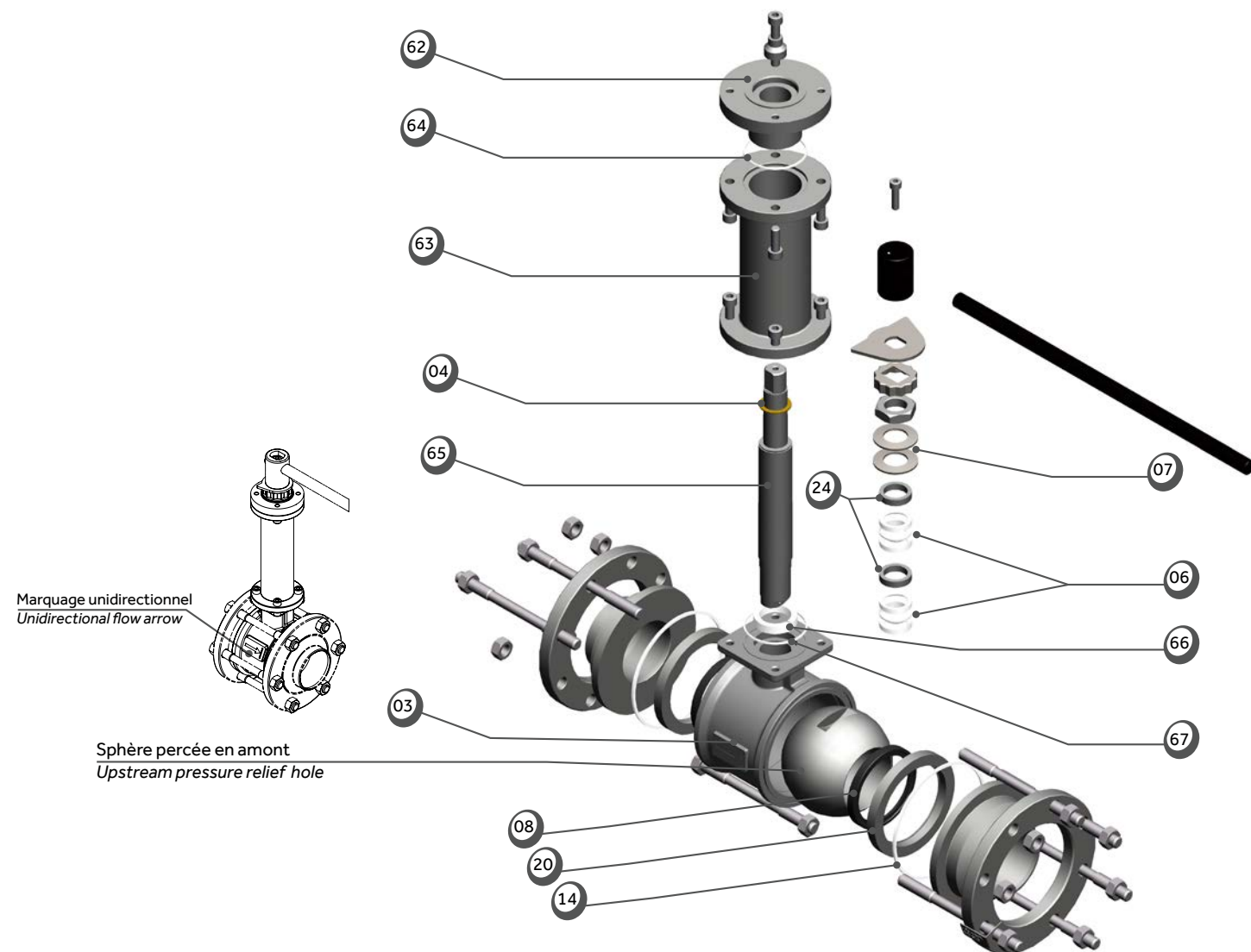

Marquage unidirectionnel
Unidirectional flow arrow

Sphère percée en amont
Upstream pressure relief hole

N°	Nb	Description	Matière (EN)
03	1	Corps	1.4409
04	1	Rondelle de friction	PTFE 20 % PEEK
06	2	Garniture de presse étoupe	PTFE
07	2	Rondelle ressort	1.4310
08	2	Siège	PTFE+Carbone
14	2	Joints de corps	PTFE
20	2	Support siège	1.4404
24	2	Fouloir	1.4404
62	1	Bride de commande manuelle	1.4404
63	1	Corps de rehausse	1.4307
64	1	Joint de platine	PTFE
65	1	Tige de rehausse	1.4404
66	1	Bague de guidage fendue	PTFE
67	1	Joint de platine	PTFE

Item	Qty	Description	Material (ASTM)
03	1	Body	CF-3M
04	1	Stem thrust seal	20%PEEK PTFE
06	2	Gland packing	PTFE
07	2	Spring washers	301
08	2	Seat	PTFE+Carbon
14	2	Body seal	PTFE
20	2	Seat support	316L
24	2	Gland	316L
62	1	Manuel flange	316L
63	1	Extension's body	304L
64	1	Flat seal	PTFE
65	1	Extended stem	316L
66	1	Split ring	PTFE
67	1	Flat seal	PTFE

**NOMENCLATURE
COMPONENTS**

PY4 CY sécurité feu

DN 08 à 50

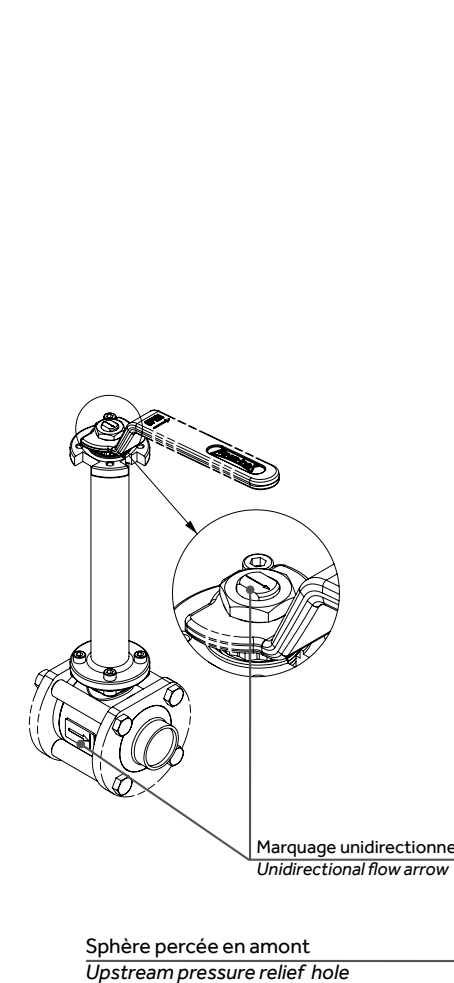

Marquage unidirectionnel
Unidirectional flow arrow

Sphère percée en amont
Upstream pressure relief hole

Sur demande : version Sécurité Feu
selon EN ISO 10497

N°	Nb	Description	Matière (EN)
03	1	Corps	1.4409
04	1	Rondelle de friction	PTFE 20 % PEEK
06	2	Garniture de presse étoupe	Graphite
07	4	Rondelle ressort	1.4310
08	2	Siège	PTFE+Carbone
14	2	Joints de corps	Graphite
24a	2	Fouloir	1.4404
24b	1	Bague de guidage	1.4404
63	1	Corps de rehausse	1.4307
65	1	Tige de rehausse	1.4404
66	1	Bague de guidage fendue	PTFE
67	1	Joint de platine coté robinet	Graphite

PY4 CY fire safe

Size 1/4" to 2"

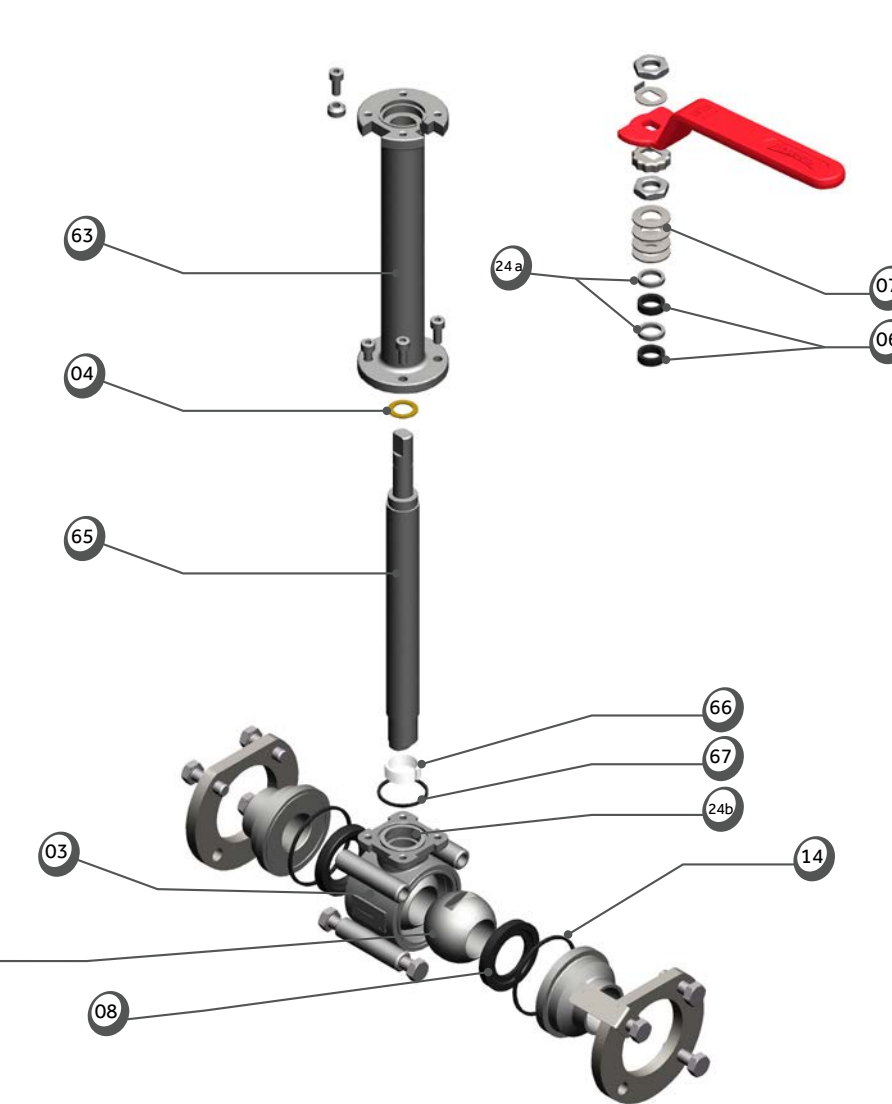

On request: Fire Safe version
according EN ISO 10497

Item	Qty	Description	Material (ASTM)
03	1	Body	CF-3M
04	1	Stem thrust seal	20%PEEK PTFE
06	2	Gland packing	Graphite
07	4	Spring washers	301
08	2	Seat	PTFE+Carbon
14	2	Body seal	Graphite
24a	2	Gland	316L
24b	1	Guide ring	316L
63	1	Extension's body	304L
65	1	Extended stem	316L
66	1	Split ring	PTFE
67	1	Flat seal (valve)	Graphite

**NOMENCLATURE
COMPONENTS**

PY4 CY sécurité feu

DN 65 à 100

PY4 CY fire safe

Size 2" 1/2 to 4"

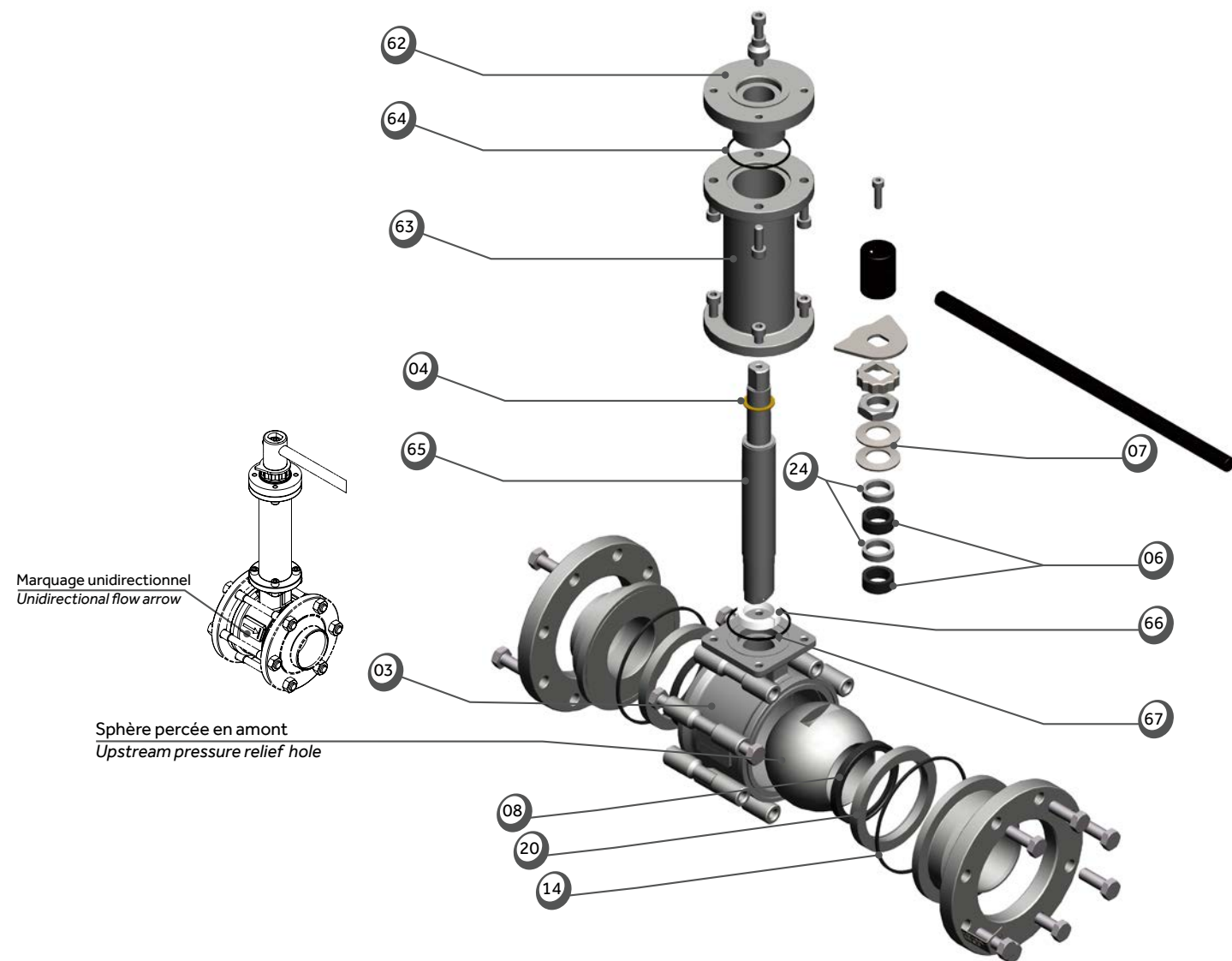

Sur demande : version Sécurité Feu selon EN ISO 10497

On request: Fire Safe version according EN ISO 10497

N°	Nb	Description	Matière (EN)
03	1	Corps	1.4409
04	1	Rondelle de friction	PTFE 20 % PEEK
06	2	Garniture de presse étoupe	PTFE
07	2	Rondelle ressort	1.4310
08	2	Siège	PTFE+Carbone
14	2	Joints de corps	PTFE
20	2	Support siège	1.4404
24	2	Fouloir	1.4404
62	1	Bride de commande manuelle	1.4404
63	1	Corps de rehausse	1.4307
64	1	Joint de platine	PTFE
65	1	Tige de rehausse	1.4404
66	1	Bague de guidage fendue	PTFE
67	1	Joint de platine	PTFE

Item	Qty	Description	Material (ASTM)
03	1	Body	CF-3M
04	1	Stem thrust seal	20%PEEK PTFE
06	2	Gland packing	PTFE
07	2	Spring washers	301
08	2	Seat	PTFE+Carbon
14	2	Body seal	PTFE
20	2	Seat support	316L
24	2	Gland	316L
62	1	Manuel flange	316L
63	1	Extension's body	304L
64	1	Flat seal	PTFE
65	1	Extended stem	316L
66	1	Split ring	PTFE
67	1	Flat seal	PTFE

PY4 CY

DN 08 à 50

PY4 CY

Size 1/4" to 2"

PY4 CY

DN 65 à 100

PY4 CY

Size 2" 1/2 to 4"

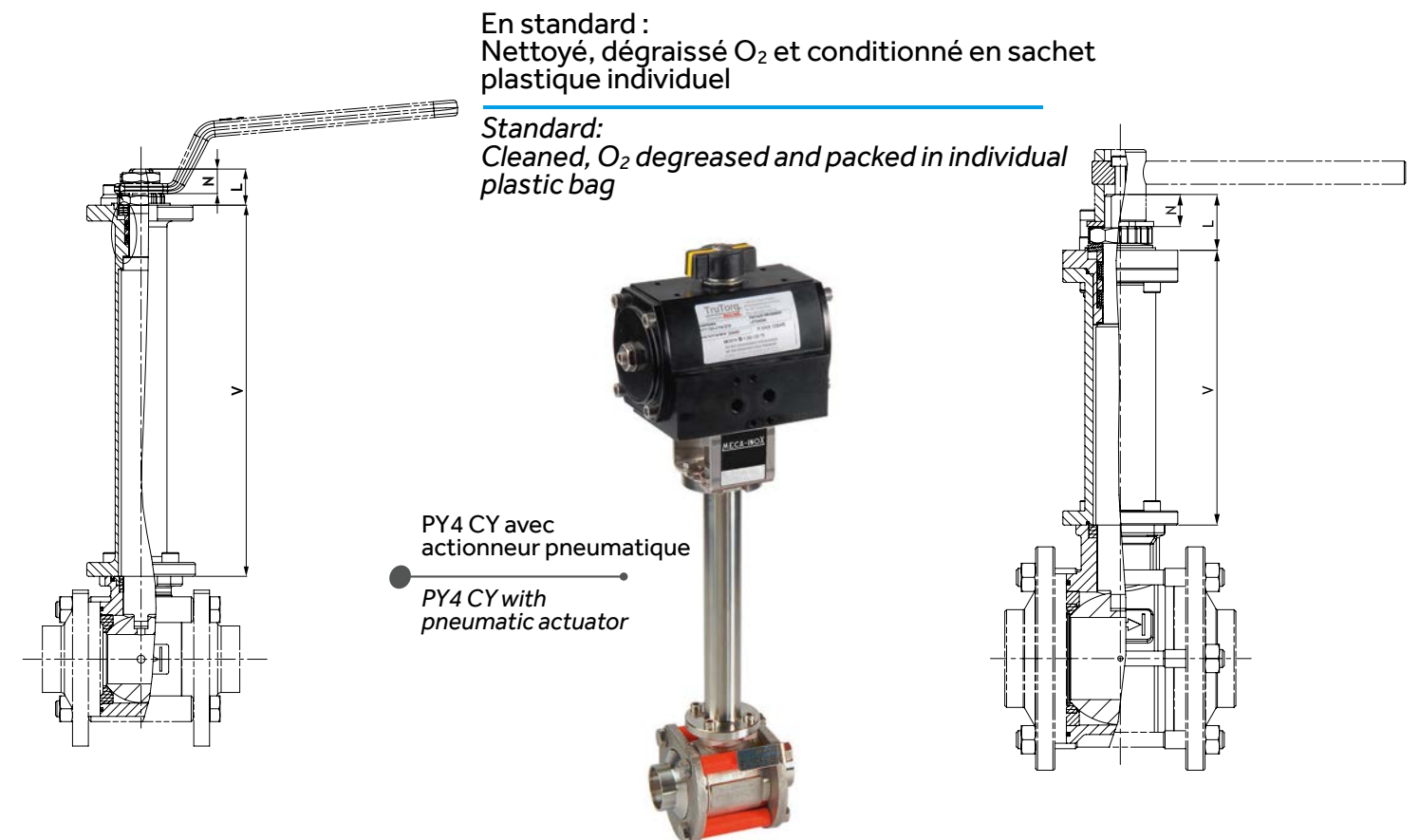

En standard :
Nettoyé, dégraissé O₂ et conditionné en sachet plastique individuel

Standard:
Cleaned, O₂ degreased and packed in individual plastic bag

PY4 CY avec actionneur pneumatique
PY4 CY with pneumatic actuator

Dimensions & couples de manœuvre Size & operating torques

DN Size	ΔP Max. -196°C / -320°F (Bar)	PN (Bar)	L	N	V	Volume tampon gazeux Volume gas buffer	Couple de manœuvre à -196°C Operating torques at -320°F
08-12	1/4"-3/8"	40	100	13.4	8.7	157	18 cm ³ 6 N.m
15	1/2"	40	100	13.4	8.7	157	15 cm ³ 12 N.m
20	3/4"	40	100	18.4	12.6	188	15 cm ³ 16 N.m
25	1"	40	70	18.4	12.6	188	15 cm ³ 26 N.m
32	1"1/4	40	70	24.2	16.2	211.5	26 cm ³ 52 N.m
40	1"1/2	40	50	24.2	16.2	211.5	26 cm ³ 86 N.m
50	2"	40	50	29.6	19	208.8	106 cm ³ 158 N.m
65	2"1/2	10	40	43.2	25	214	43 cm ³ 172 N.m
80	3"	10	40	43.2	25	216	264 cm ³ 172 N.m
100	4"	10	25	49	30	216	191 cm ³ 301 N.m

Version 3 voies / Entrée Horizontale
Passage intégral et Standard

3VLH

Passage en L
Distribution du fluide

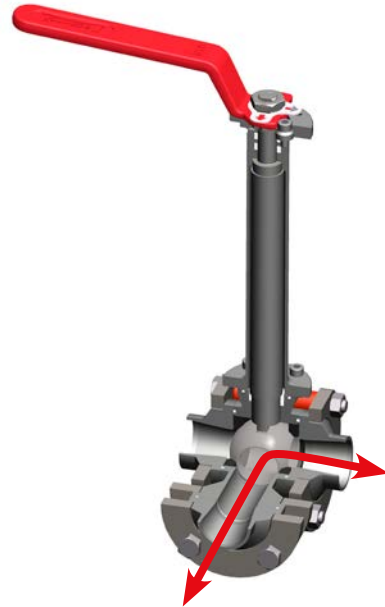

3-way version / Horizontal inlet
Full bore & reduced bore

3VLH

L port
Diverting flow



3VTH

Passage en T
Distribution du fluide ou mélange

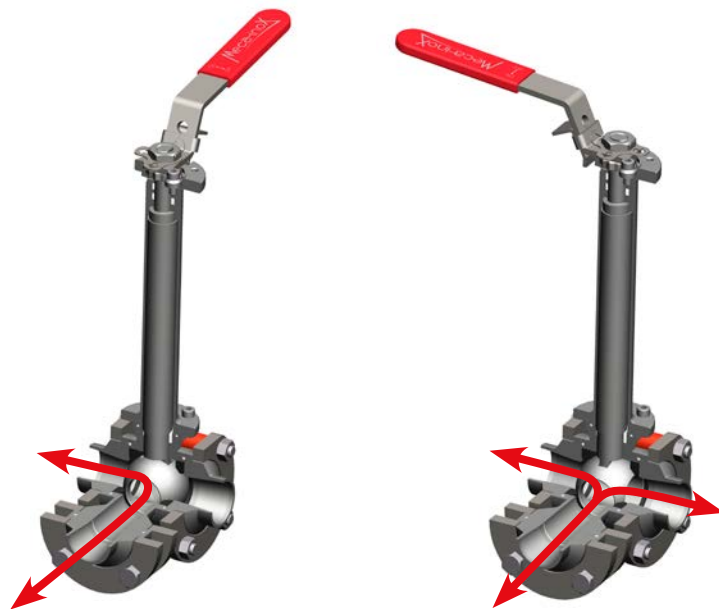

3VTH

T port
Diverting flow or mixing



Version 3 voies / Entrée Verticale
Passage intégral et Standard

3VLV

Passage en L
Distribution ou blocage du fluide

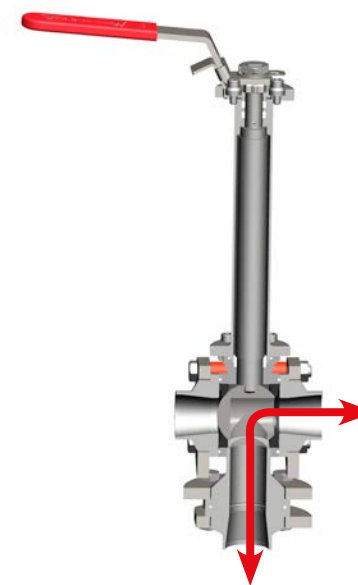

3-way version / Vertical inlet
Full bore & reduced bore

3VLV

L port
Diverting flow or flow stop

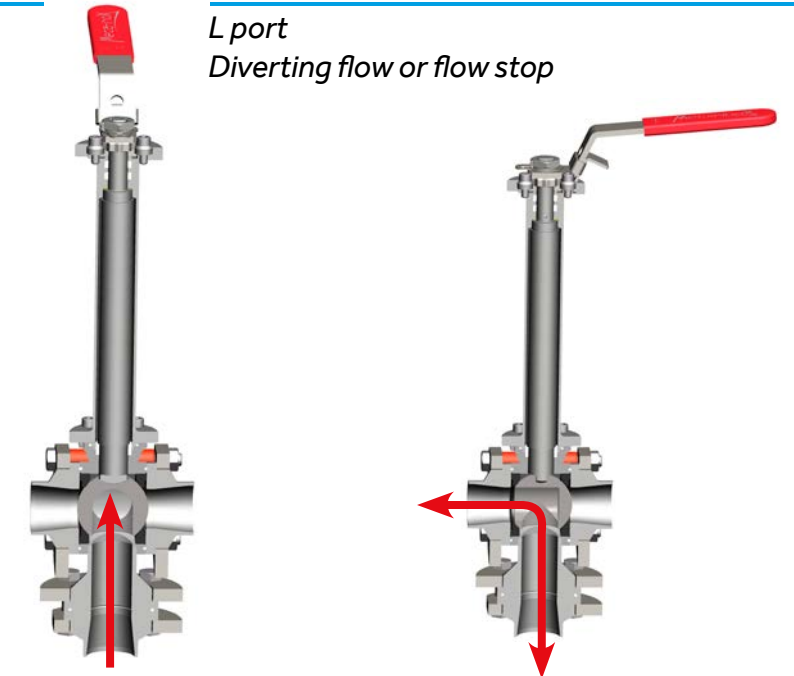

Dimensions entrée Horizontale & Verticale Horizontal & Vertical inlet size

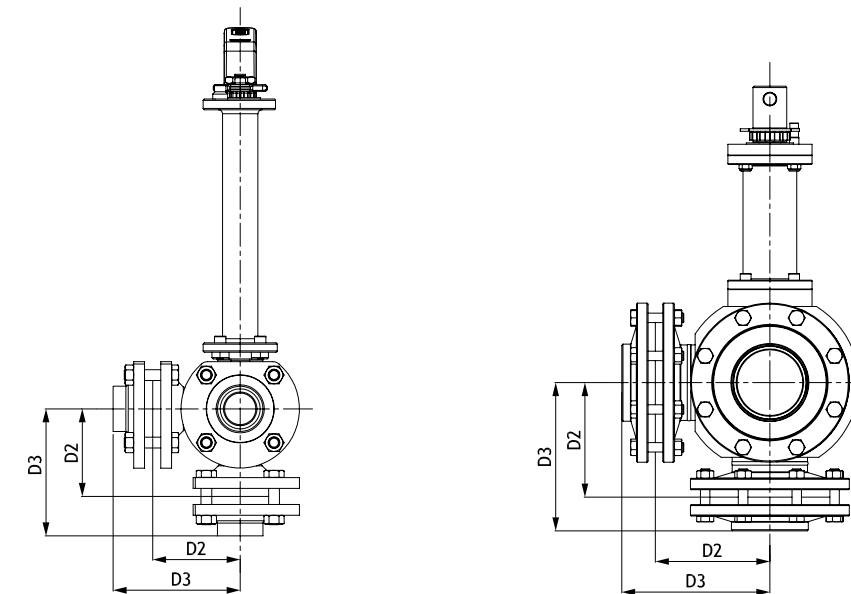

DN Size	08 1/4"	12 3/8"	15 1/2"	20 3/4"	25 1"	32 1 1/4"	40 1 1/2"	50 2"	65 2 1/2"	80 3"	100 4"
D2	45	45	50	60	65	72	80	103	135	149	170
D3	67.3	67.3	72.8	86.7	94.3	102.9	114.4	142.5	183	202	220

CRYO

ROBINETS MIXTE BRONZE / INOX
COMBINED VALVE : BRONZE / STAINLESS STEEL

Application oxygène liquide / PY4 CY

Embouts Socket Welding SW

Matière sièges :
PTFE + Carbone

Perçage boule côté amont
pour décompression
en position fermée

Nettoyé, dégraissé O₂ et
conditionné en sachet
plastique individuel



Liquid oxygen application / PY4 CY

Socket Welding ends SW

Seats material:
PTFE + Carbon

Upstream vent hole
for cavity relief in
the closed position

Cleaned, O₂ degreased
and packed in individual
plastic bag



Application oxygène gazeux PS4

Embouts Socket Welding SW

Matière sièges :
TFM1600

Nettoyé, dégraissé O₂ et
conditionné en sachet
plastique individuel



Gas oxygen application / PS4

Socket Welding ends SW

Seats material:
TFM1600

Cleaned, O₂ degreased
and packed in
individual plastic bag



Caractéristiques techniques PY4 CY / PS4 Technical data PY4 CY / PS4

Matière corps & tige : 1.4404
Stem & body material: 316L

Matière sphère :
Bronze CW 453 K
Dureté élevée (HB > 120)
Evite le matage par la tige
de manœuvre

Ball material:
Bronze CW 453 K
High hardness
(HB > 120)
Prevents matting
by the stem

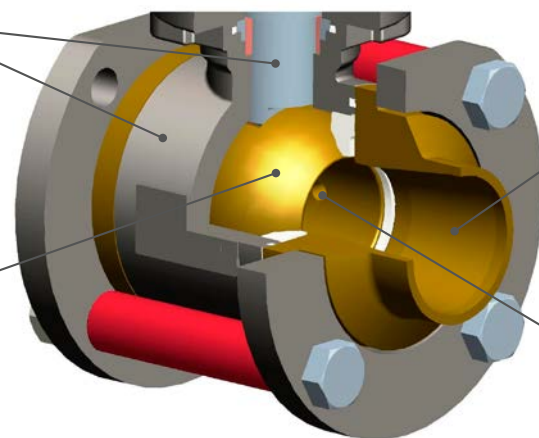

Embouts :
Socket Welding
passage intégral
Matière :
Bronze CC 491 K

Connection:
Socket Welding
Full bore
Material:
Bronze CC 491 K

Perçage amont pour
décompression
(en standard sur PY4/PY4 CY)
(en option sur PS4)

Upstream vent hole for
cavity relief
(standard on PY4/PY4 CY)
(option on PS4)

MOTORISATION PNEUMATIQUE
PNEUMATIC ACTUATION

PY4 CY Motorisée

DN 08 à 50

PY4 CY actuated

Size 1 / 4" to 2"

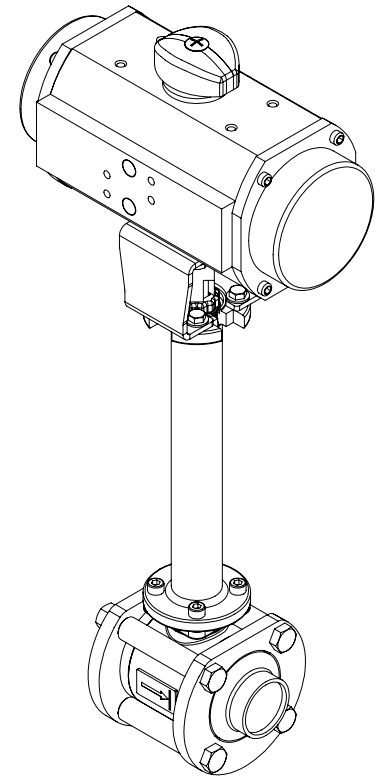
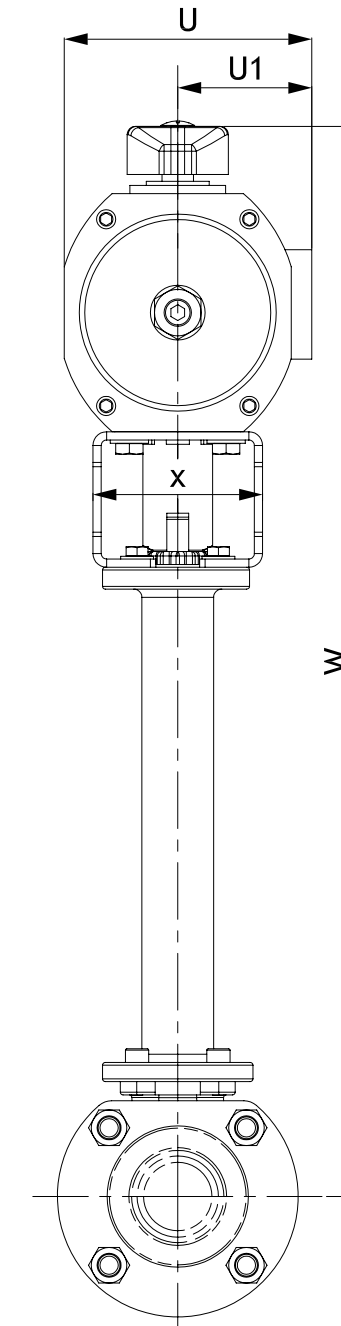
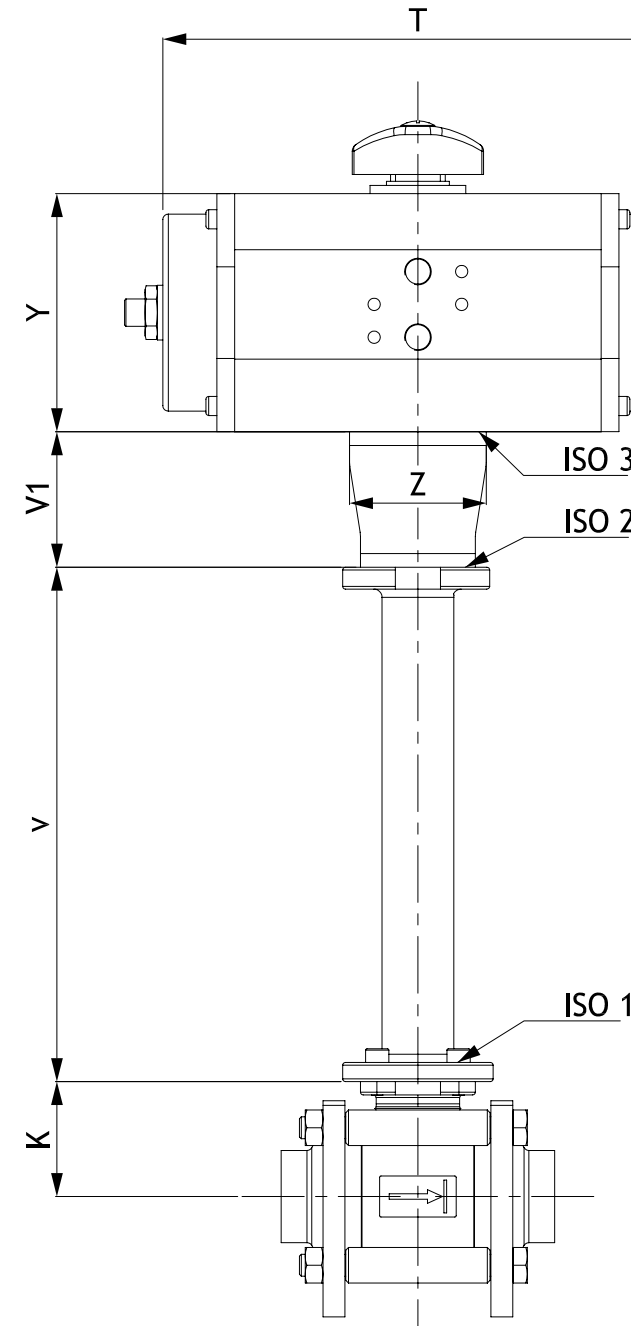

MOTORISATION PNEUMATIQUE
PNEUMATIC ACTUATION

PY4 CY Motorisée

DN 08 à 50

PY4 CY actuated

Size 1/4" to 2"

Modèle TRUTORQ Simple Effet sur PY4 CY *Spring Return TRUTORQ type on PY4 CY*

DN - Size		K	ISO 1	TRUTORQ	ISO 2	ISO 3	T	U	U1	V1	V	W	X	Y	Z		
Nominal Full	Standard Reduced																
08-12	1/4"-3/8"	15	1/2"	27.5	F03	2TSR003	F03	F04	149.5	69.5	38	47	157	321.5	52	70	42
15	1/2"	20	3/4"	31	F03	2TSR005	F03	F05	186.5	90.5	49	47	157	342	62	87	50
20	3/4"	25	1"	37.9	F04	2TSR005	F04	F05	162	105	57	49.5	188	404.4	62	109	50
25	1"	32	1"1/4	42	F04	2TSR008	F04	F07	194	121	67	49.5	188	418	82	118.5	69
32	1"1/4	40	1"1/2	54	F05	2TSR020	F05	F07	218	136.5	72	49.5	211.5	475.5	82	140.5	69
40	1"1/2	50	2"	59	F05	2TSR020	F05	F10	218	136.5	72	49.5	211.5	480.5	82	140.5	69
50	2"	65	2"1/2	73	F07	2TSR035	F07	F10	266	156	78	79.5	208	547	120	166.5	105

Données pour température de service cryogénique (-196 °C) et 6 bars d'air comprimé à : ΔP 40 bars Max (DN 10 à 32), ΔP 20 bars Max (DN40 à 50)

Values given for cryogenics service (-196°C) and 6 bars air supply pressure at: ΔP 40 bars Max (DN 10 to 32), ΔP 20 bars Max (DN40 to 50)

Modèle TRUTORQ Double Effet sur PY4 CY *Double Acting TRUTORQ type on PY4 CY*

DN - Size		K	ISO 1	TRUTORQ	ISO 2	ISO 3	T	U	U1	V1	V	W	X	Y	Z		
Nominal Full	Standard Reduced																
08-12	1/4"-3/8"	15	1/2"	27.5	F03	2TDA003	F03	F04	14.95	69.5	38	47	157	321.5	52	70	42
15	1/2"	20	3/4"	31	F03	2TDA003	F03	F04	149.5	69.5	38	47	157	325	52	70	42
20	3/4"	25	1"	37.9	F04	2TDA003	F04	F04	149.5	69.5	38	49.5	188	365.4	62	70	50
25	1"	32	1"1/4	42	F04	2TDA005	F04	F05	186.5	90.5	49	49.5	188	386.5	62	87	50
32	1"1/4	40	1"1/2	54	F05	2TDA005	F05	F05	186.5	90.5	49	49.5	211.5	422	62	87	50
40	1"1/2	50	2"	59	F05	2TDA008	F05	F05	162	105	57	49.5	211.5	449	62	109	50
50	2"	65	2"1/2	73	F07	2TDA012	F07	F07	194	121	67	79.5	208	499	85	118.5	69

Données pour température de service cryogénique (-196 °C) et 6 bars d'air comprimé à : ΔP 40 bars Max (DN 10 à 32), ΔP 20 bars Max (DN40 à 50)

Values given for cryogenics service (-196°C) and 6 bars air supply pressure at: ΔP 40 bars Max (DN 10 to 32), ΔP 20 bars Max (DN40 to 50)

PY4 CY ΔP: 40 bars (DN 10 - 32), 20 bars (DN40- 50)

DN	Air Moteur (Bar)	Double Effet Double acting Code	Simple Effet Spring return Code
08-12 F03	6	KPNI410 0411 2TDA003	KPNI410 0411 2TSR003 N66
15 F03	6	KPNI410 0411 2TDA003	KPNI410 0514 2TSR005 N66
20 F04	6	KPNI420 0411 2TDA003	KPNI420 0514 2TSR005 N66
25 F04	6	KPNI420 0514 2TDA005	KPNI420 0514 2TSR008 N44
32 F05	6	KPNI432 0514 2TDA005	KPNI432 0717 2TSR020 N44
40 F05	6	KPNI432 0514 2TDA008	KPNI432 0717 2TSR020 N44
50 F07	6	KPNI450 0717 2TDA012	KPNI450 1022 2TSR035 N44

MOTORISATION PNEUMATIQUE
PNEUMATIC ACTUATION

PY4 CY Motorisée

DN 65 à 100

PY4 CY actuated

Size 2" 1/2 to 4"

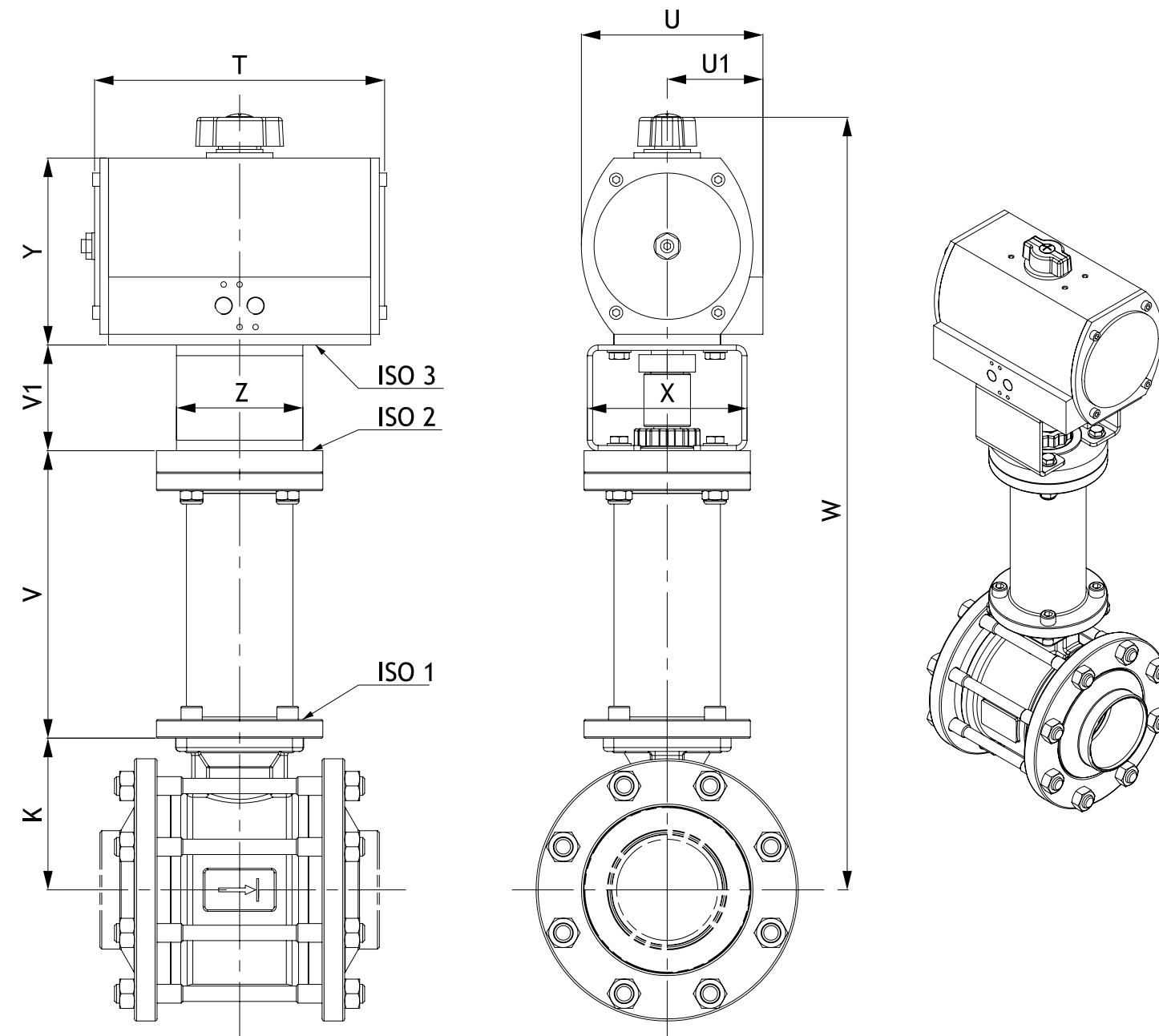

CRYO

MOTORISATION PNEUMATIQUE
PNEUMATIC ACTUATION

PY4 CY Motorisée

DN 65 à 100

PY4 CY actuated

Size 2" 1/2 to 4"

Modèle TRUTORQ Simple Effet sur PY4 CY *Spring Return TRUTORQ type on PY4 CY*

DN - Size				K	ISO 1	TRUTORQ	ISO 2	ISO 3	T	U	U1	V	V1	W	X	Y	Z
Nominal Full	Standard Reduced																
65	2"1/2	80	3"	104	F07	2TSR055	F07	F12	312	191	95.5	214	79.5	635	132	207.5	120
80	3"	100	4"	114	F10	2TSR055	F10	F12	312	191	95.5	216	79.5	647	136	207.5	118
100	4"	125	5"	133	F10	2TSR100	F10	F14	361	227	113.5	216	79.5	708.5	158	250	140

Données pour température de service cryogénique (-196 °C) et 6 bars d'air comprimé à : ΔP 10 bars Max (DN 65 à 100)

Values given for cryogenics service (-196°C) and 6 bars air supply pressure at: ΔP 10 bars Max (DN 65 to 100)

Modèle TRUTORQ Double Effet sur PY4 CY *Double Acting TRUTORQ type on PY4 CY*

DN - Size				K	ISO 1	TRUTORQ	ISO 2	ISO 3	T	U	U1	V	V1	W	X	Y	Z
Nominal Full	Standard Reduced																
65	2"1/2	80	3"	104	F07	2TDA020	F07	F07	218	136.5	72	214	79.5	558	85	140.5	69
80	3"	100	4"	114	F10	2TDA020	F10	F07	218	136.5	72	216	79.5	570	85	140.5	69
100	4"	125	5"	133	F10	2TDA035	F10	F10	266	156	78	216	79.5	615	120	166.5	95

Données pour température de service cryogénique (-196 °C) et 6 bars d'air comprimé à : ΔP 10 bars Max (DN 65 à 100)

Values given for cryogenics service (-196°C) and 6 bars air supply pressure at: ΔP 10 bars Max (DN 65 to 100)

PY4 Δ CY: 10 bars (DN65 - 100)

DN	Air Moteur (Bar)	Double Effet <i>Double acting</i> Code	Simple Effet <i>Spring return</i> Code
65 F07	6	KPNI2P065 0717 2TDA020	KPNI2P065 1227 2TSR055 N44
80 F10	6	KPNI2P080 0717 2TDA020	KPNI2P080 1227 2TSR055 N44
100 F10	6	KPNI2P100 1022 2TDA035	KPNI2P100 1436 2TSR100 N44

DN 15 à 200

DIN PN 16 / PN 40
Passage intégral
Platine ISO
Acier inoxydable et carbone
Version chimie & version sécurité feu



Série en acier inoxydable
Stainless steel series

Size 1/2" to 8"

PN 16 / PN 40
Full bore
ISO top flange
Stainless steel and carbon steel
Chemical version & Fire safe design



Série motorisée
Actuated series



Série en acier carbone
Carbon steel series



Série motorisée
Actuated series

2-PCS

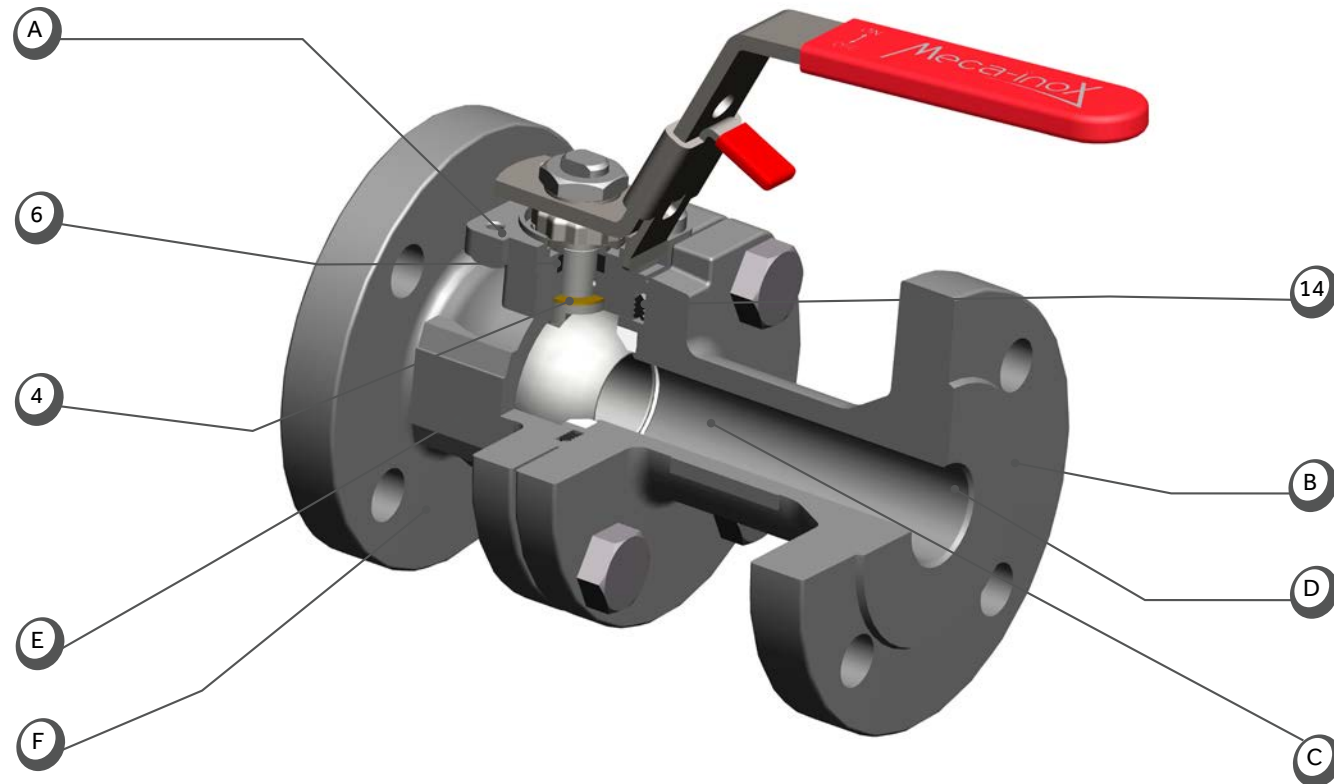

- A • Platine NF EN ISO 5211**
Elle autorise toute motorisation et les encoches permettent le verrouillage du levier en position ouvert ou fermé.
- B • Faces de brides**
Surélevées et usinées.
- C • Usinage**
Afin d'assurer l'absence d'accrochage et la bonne qualité des fonderies, toutes les surfaces internes sont usinées.
- D • Passage**
Passage intégral en standard.
- E • Marquage selon EN19**
Marquage sur le corps, permet d'identifier le PN / DN, nuance matière, fabricant et limite d'utilisation.
- F • Bride de corps**
Une construction homogène qui évite les concentrations de contraintes au niveau du corps car les dimensions des brides de corps sont cohérentes avec les brides PN40 ou PN16 de raccordement sur la tuyauterie.
- 4 • Rondelle de friction**
En PTFE chargé PEEK elle assure une meilleure durée de vie du presse-étoupe.
- 6 • Presse-étoupe**
Boîtier usiné et équipé de garniture de type chevron. Le presse-étoupe est antistatique et agréé TA-Luft. Il existe aussi en version "s écurité feu".
- 14 • Joint de corps**
3 versions disponibles : en PTFE "version Chimie" - en Graphite "version Sécurité Feu" suivant EN ISO 10497 avec barrière chimique PTFE évitant le contact du graphite avec le fluide - en Fluorosilicone pour contraintes thermiques.

- A • NF EN ISO 5211 top flange**
Ensures any motorization and notches allow the handle's locking in opened or closed position.
- B • Flanges faces**
Raised face machined as standard.
- C • Machining**
In order to ensure the absence of trapping medium and the good quality of the foundries, all the inner parts are machined.
- D • Bore**
Full bore as standard.
- E • Marking according to EN19**
Located on the body and on the connector, PN/DN, material tag manufacturer.
- F • Body flange**
A homogeneous construction which avoids stress concentration on the body flange as body flange dimensions are coherently designed with PN40 or PN16 connecting flanges on the pipe.
- 4 • Stem thrust seal**
Made from 20% PEEK filled PTFE, it ensures a better lifespan for the gland-packing.
- 6 • Gland-packing**
Box packing is manufactured and equipped with "V-ring" packing. This design is antistatic and tested according to TA-Luft. "Fire Safe" version is available.
- 14 • Body seal**
3 versions available: PTFE for the "chemistry Version" - Graphite for the "fire safety" version according to EN ISO 10497 with PTFE chemical barrier avoiding fluid contact with graphite - Fluorosilicone for thermal stress.

**SYSTEME D'ÉTANCHÉITE
SEALING DESIGN**

Presse-étoupe

Gland-packing

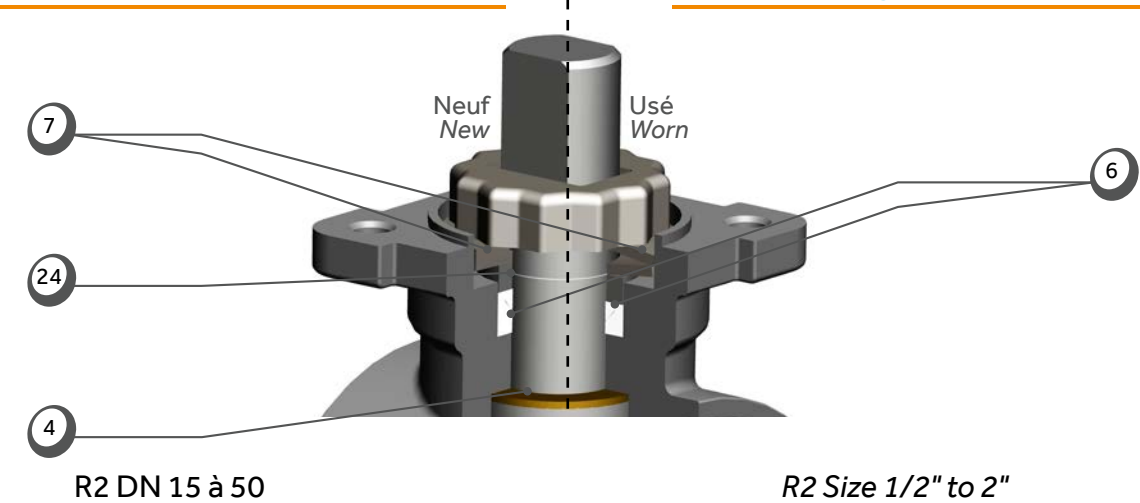

- Conception suivant NF EN 12516-1, DIN 3841, ANSI B16.34
- Antistatique suivant ISO 7121, NF EN 1983
- Garniture (6) chargée PTFE+carbone+graphite
- Ensemble bille / ressort (B) entre tige & corps et tige & boisseau (DN > 50)
- Rondelle de friction (4) en PTFE renforcé PEEK
- Étanchéité par garniture de type "chevron" (6) permettant de maintenir l'étanchéité lorsque la pression vient du corps du robinet
- Fouloir inox (24)
- Rattrapage du jeu de la garniture par rondelles ressort (7)

- Design according NF EN 12516-1, DIN 3841, ANSI B16.34
- Antistatic gland packing according to ISO 7121, NF EN 1983
- Gland packing (6) in PTFE+carbon+graphite
- Ball / spring system (B) between stem & body and stem & ball (DN > 50)
- Thrust seal (4) in PEEK reinforced PTFE
- Sealing with a "V-ring" packing (6) to allow sealing under pressure coming from the valve body
- Gland in stainless steel (24)
- Wear compensation thanks to the pair of spring washers (7)

R2 DN 65 à 200

R2 Size 2"1/2 to 8"

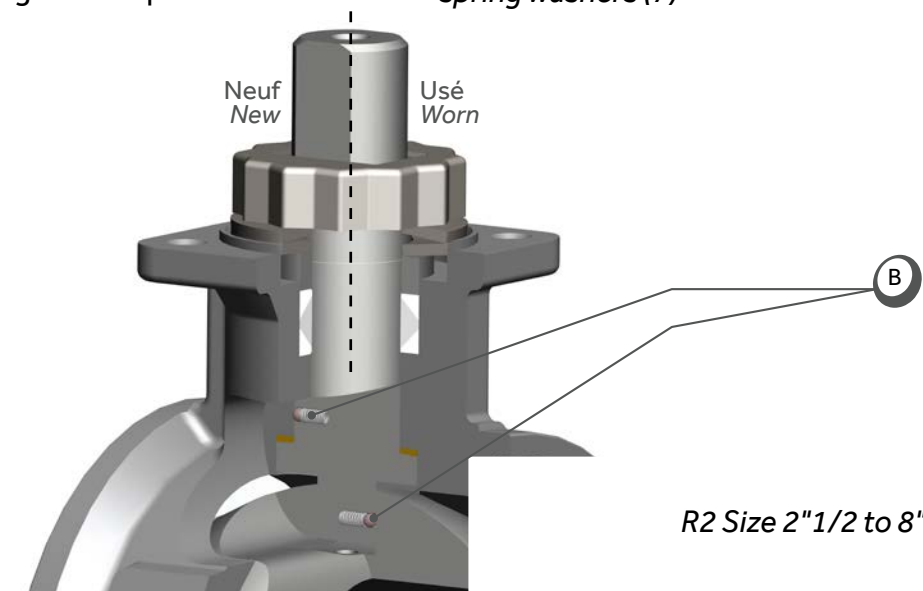

Sièges et joint de corps

Seats and body seal

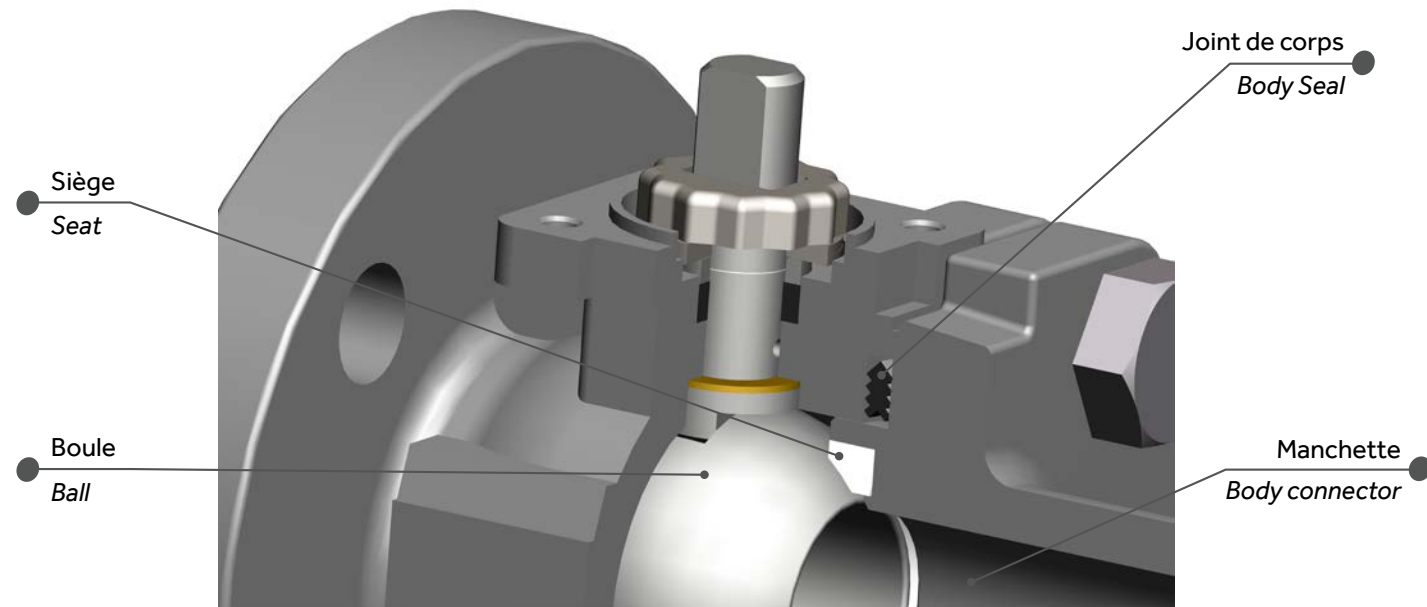

Joint de corps encastré garantissant l'étanchéité intérieur / extérieur.

Profils de sièges conçus pour une étanchéité amont / aval optimale.

Élasticité des sièges absorbant les contraintes de pression.

Portée progressive qui optimise les couples de manœuvre.

Encapsulated body seals to guarantee internal/external tightness.

Seats profiles designed for upstream/downstream sealing.

Seats elasticity to absorb pressure stress

Progressive bearing to optimize operating torques.

Exemple

Example

R2	S	4	L	1	N	025 (DN/Size)
Produit Body	Matériaux des sièges Seats material	Pression nominale Pressure rating	Encombrement face à face Face to Face	Matériaux de presse-étoupe Gland packing material	Passage Port	Nuance Body material
R2 Fonderie de précision Investment casting	S TFM1600	4 PN40 - DN 15 à 100 1/2" to 4"	L DIN 3202 - Série 1 Long pattern	1 PTFE antistatique DN 15 à 50 Antistatic PTFE 1/2" to 2"	N Intégral Full bore	I Inox Stainless steel
	Z PTFE 20% PEEK 20% PEEK PTFE	1 PN16 - DN 100 à 200 4" to 8"	C DIN 3202 - Série 4 Short pattern	0 PTFE - DN 65 à 100 PTFE - 2" 1/2 to 4"		A Acier au carbone Carbon steel
	H Sécurité feu (SF) Fire safe			9 Graphite (sécurité feu) Graphite (Fire Safe)		
	J TFM 1600			6 Fluorosilicone Special thermal fluids DN 15 - 50 / 1/2" - 2"		
	P PEEK			7 Fluorosilicone Special thermal fluids DN 65 - 100 / 2" 1/2 - 4"		

**NOMENCLATURE
COMPONENTS**

DN 15 à 50

Size 1/2" to 2"

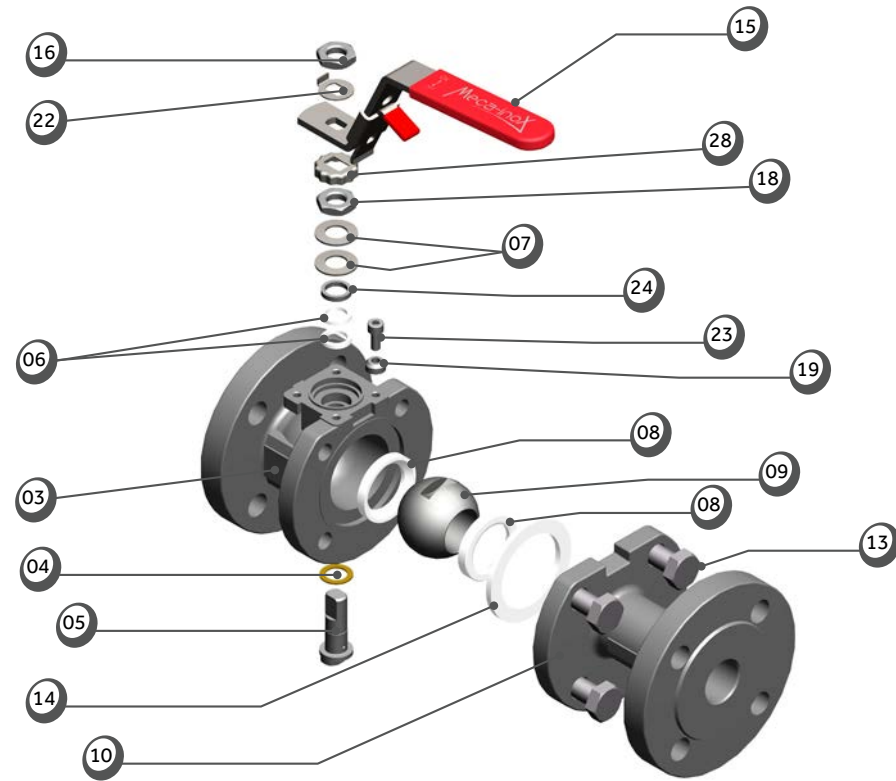

N°	Nb	Description	Matière (EN)		Item Qty	Description	Material (ASTM)			
			Inox	Acier			S.steel	C.steel		
03	1	Corps monobloc ISO	1.4408	1.0619 Cataphorésé	03	1	Body	A351 CF 8 M A216 WCB Cataphoresis treatment		
04	1	Rondelle de friction	PTFE 20 % PEEK	PTFE 20 % PEEK	04	1	Stem thrust seal	20%PEEK PTFE 20%PEEK PTFE		
05	1	Tige de manœuvre	1.4404	1.4404	05	1	Stem	316L 316L		
06	1	Garniture de presse-étoupe Version chimie Version Sécurité Feu	PTFE 33 % C + 2 % Gr	PTFE 33 % C + 2 % Gr	06	1	Gland packing Chemical version Fire-Safe version	33%C+2%Gr PTFE Graphite Graphite	33%C+2%Gr PTFE Graphite Graphite	
07	4	Rondelles ressort	1.4310	1.4310	07	4	Spring washers	301 301		
08	2	Sièges	PTFE	PTFE	08	2	Seats	PTFE PTFE		
09*	1	Tournant sphérique	1.4409	1.4409	09*	1	Ball	CF3M (316L) CF3M (316L)		
10	1	Manchette de raccordement	1.4408	1.0619 Cataphorésé	10	1	Body connector	A351 CF 8 M A216 WCB Cataphoresis treatment		
13	4	Vis TH (DIN F1) DN15 & DN25	1.4301	Classe 8.8	13	4	Screw (DIN F1) Size 1/2" & 1"	304	Class 8.8	
13b	6	Goujons DN15 & DN25 DN20 + DN32 à DN50	1.4301	1.4301	13b	1	Stud (DIN F4) Size 1/2" & 1"	304	304	
14	1	Joint de corps Version chimie Version Sécurité Feu	PTFE	PTFE	14	1	Body seal Chemical version Fire-Safe version	PTFE PTFE 316L + Graphite	PTFE PTFE 316L + Graphite	
15	1	Levier standard Levier option	1.4301	1.4301	15	1	Handle standard Handle option	304 See OPTIONS FOR OPERATION	304 See OPTIONS FOR OPERATION	
17	4	Écrous de serrage (DIN F4) DN15 & DN25	1.4301	Classe 8.8	17	4	Nut screw (DIN F4) Size 1/2" & 1"	304	Class 8.8	
17	6	DN20 + DN32 à DN50	1.4301	Classe 8.8	17	6	Size 3/4" + 1" 1/2 to 2"	304	Class 8.8	
18	1	Écrou de fouloir	1.4404	1.4404	18	1	Nut gland	316L 316L		
19	1	Bague de butée	1.4307	1.4307	19	1	Locking plug	304L 304L		
22	1	Frein d'écrou de levier	1.4307	1.4307	22	1	Nut stop	304L 304L		
23	1	Vis Chc de butée	1.4301	1.4301	23	1	Screw stop	304 304		
24	1	Fouloir	1.4404	1.4404	24	1	Gland	316L 316L		
28	1	Frein d'écrou de P.E	1.4307	1.4307	28	1	Stop nut gland	304L 304L		

* Sphère percée en standard
* Drilled ball as standard

**NOMENCLATURE
COMPONENTS**

DN 65 à 150

Size 2" 1/2 to 6"

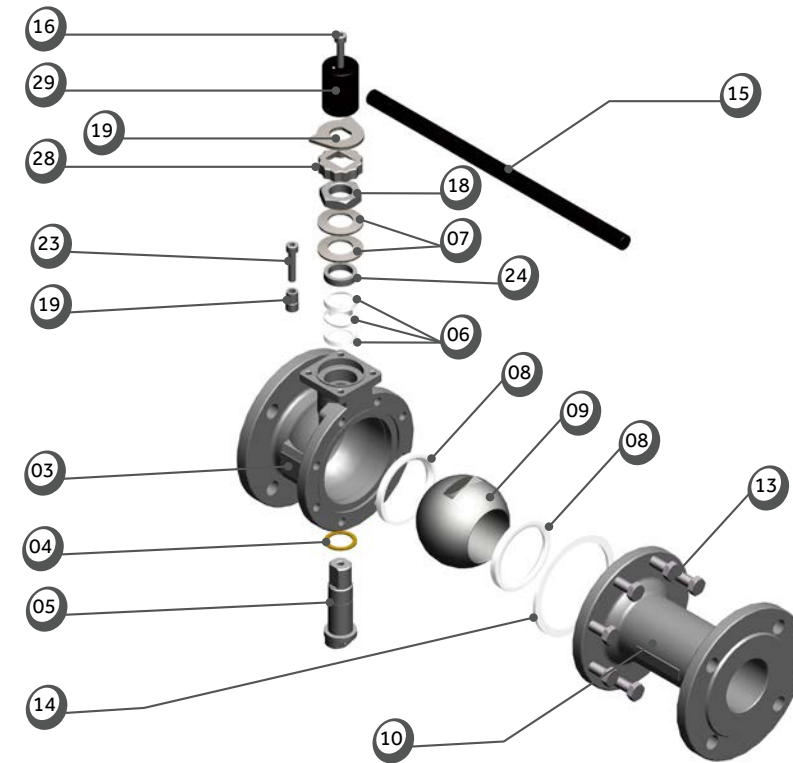

N°	Nb	Description	Matière (EN)		Item Qty	Description	Material (ASTM)		
			Inox	Acier			S.steel	C.steel	
03	1	Corps monobloc ISO	1.4408	1.0619 Cataphorésé	03	1	Body	A351 CF 8 M A216 WCB Cataphoresis treatment	
04	1	Rondelle de friction	PTFE 20 % PEEK	PTFE 20 % PEEK	04	1	Stem thrust seal	20%PEEK PTFE 20%PEEK PTFE	
05	1	Tige de manœuvre	1.4404	1.4404	05	1	Stem	316L 316L	
06	1	Garniture de presse-étoupe Version chimie Version Sécurité Feu	PTFE	PTFE	06	1	Gland packing Chemical version Fire-Safe version	PTFE Graphite Graphite	PTFE PTFE PTFE
07	2	Rondelles ressort	1.4310	1.4310	07	2	Spring washers	301 301	
08	2	Sièges	PTFE	PTFE	08	2	Seats	PTFE PTFE	
09*	1	Tournant sphérique	1.4409	1.4409	09*	1	Ball	CF3M (316L) CF3M (316L)	
10	1	Manchette de raccordement	1.4408	1.0619 Cataphorésé	10	1	Body connector	A351 CF 8 M A216 WCB Cataphoresis treatment	
13	8	Vis TH (DIN F1) DN65	1.4301	Classe 8.8	13	8	Screw (DIN F1) Size 2" 1/2	304	Class 8.8
13b	12	Goujon (DIN F4) DN65	1.4301	1.4301	13b	8	Stud (DIN F4) Size 2" 1/2	304	304
14	1	Joint de corps Version chimie Version Sécurité Feu	PTFE	PTFE	14	1	Body seal Chemical version Fire-Safe version	PTFE PTFE 316L + Graphite	PTFE PTFE 316L + Graphite
15	1	Levier standard Levier option	1.0037 Cataphorésé	1.0037 Cataphorésé	15	1	Handle standard Handle option	A283 Gr C Cataphoresis treatment See OPTIONS FOR OPERATION	A283 Gr C Cataphoresis treatment See OPTIONS FOR OPERATION
16	1	Vis de levier	1.4301	1.4301	16	1	Handle screw	304 304	
17	1	Écrous de serrage (DIN F4)	1.4301	Classe 8.8	17	1	Nut screw (DIN F4)	304 Class 8.8	
18	1	Écrou de fouloir	1.4404	1.4404	18	1	Nut gland	316L 316L	
19	1	Plaque d'arrêt	1.4307	1.4307	19	1	Stop plate	304L 304L	
19b	1	Bague de butée	1.4307	1.4307	19b	1	Locking plug	304L 304L	
23	1	Vis Chc de butée	1.4301	1.4301	23	1	Screw stop	304 304	
24	1	Fouloir	1.4404	1.4404	24	1	Gland	316L 316L	
28	1	Frein d'écrou de P.E	1.4307	1.4307	28	1	Stop nut gland	304L 304L	
29	1	Noix de manœuvre standard Noix de manœuvre option	1.0037 Cataphorésé	1.0037 Cataphorésé	29	1	Handle adaptor standard Handle adaptor option	A283 Gr C Cataphoresis treatment 303	A283 Gr C Cataphoresis treatment 303

* Sphère percée en standard
* Drilled ball as standard

**NOMENCLATURE
COMPONENTS**

DN 150 à 200

Size 6" to 8"

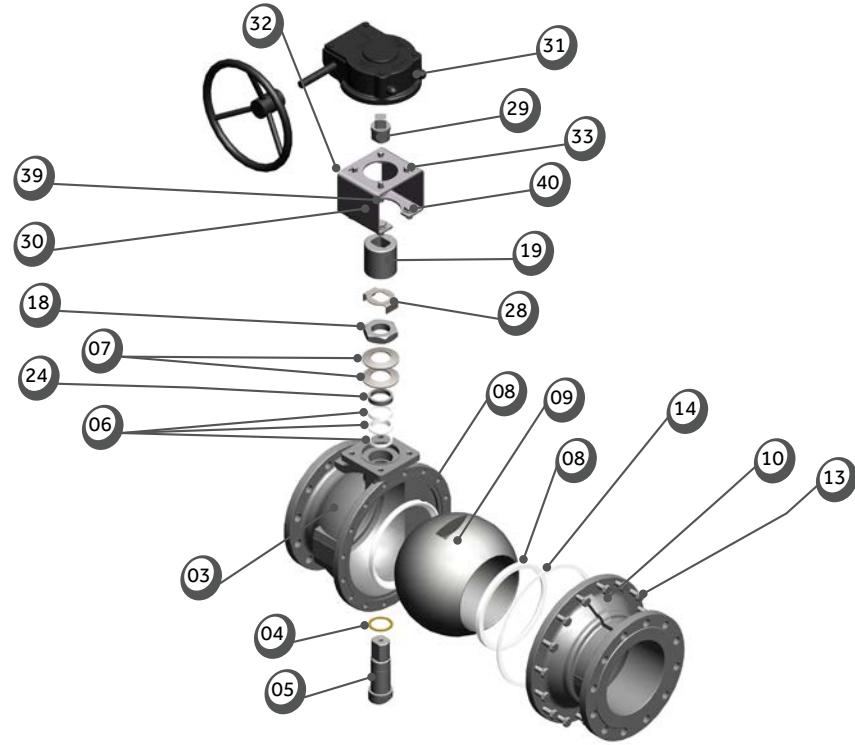

N°	Nb	Description	Matière (EN)		Item Qty	Description	Material (ASTM)	
			Inox	Acier			S.steel	C.steel
03	1	Corps monobloc ISO	1.4408	1.0619 Cataphorésé	03	1	Body	A351 CF 8 M / A216 WCB Cataphoresis treatment
04	1	Rondelle de friction	PTFE 20% PEEK	PTFE 20% PEEK	04	1	Stem thrust seal	20%PEEK PTFE / 20%PEEK PTFE
05	1	Tige de manœuvre	1.4404	1.4404	05	1	Stem	316L / 316L
06	1	Garniture de presse-étoupe	PTFE	PTFE 33% C + 2% Gr	06	1	Gland packing	33%C+2%Gr PTFE / 33%C+2%Gr PTFE
		Version chimie	33% C + 2% Gr	Version Sécurité Feu			Graphite	Graphite
07	2	Rondelles ressort	1.4310	1.4310	07	2	Spring washers	301 / 301
08	2	Sièges	PTFE	PTFE	08	2	Seats	PTFE / PTFE
09*	1	Tournant sphérique DN150 à DN200	1.4409	1.4409	09*	1	Ball Size 6" to 8"	CF3M (316L) / CF3M (316L)
10	1	Manchette de raccordement	1.4408	1.0619 Cataphorésé	10	1	Body connector	A351 CF 8 M / A216 WCB Cataphoresis treatment
13	12	Vis TH (DIN F1) DN150	1.4301	Classe 8.8	13	12	Size 6"	304 / Class 8.8
	16	DN200				Size 8"		
	14	1				Joint de corps	PTFE	
14	1	Version chimie	PTFE	PTFE	14	1	Version Sécurité Feu	316L + Graphite / 316L + Graphite
		Version Sécurité Feu	1.4404 + Graphite	1.4404 + Graphite				
18	1	Écrou de fouloir	1.4404	1.4404	18	1	Nut gland	316L / 316L
19	1	Noix de manœuvre	1.4305	1.4305	19	1	Coupling adaptor	303 / 303
24	1	Fouloir	1.4404	1.4404	24	1	Gland	316L / 316L
28	1	Frein d'écrou de P.E	1.4307	1.4307	28	1	Stop nut gland	304L / 304L
29	1	Entraîneur	1.4307	1.4307	29	1	Coupling	304L / 304L
30	1	Arcade	1.4307	1.4307	30	1	Bracket	304L / 304L
31	1	Réducteur manuel	Gg25	Gg25	31	1	Gear box	Gg25 / Gg25
32	4	Rondelle plate (coté réducteur)	1.4301	1.4301	32	4	Ring (gear box side)	304 / 304
33	4	vis TH (coté réducteur)	1.4301	1.4301	33	4	Screw (gear box side)	304 / 304
39	4	Rondelle plate (coté robinet)	1.4301	1.4301	39	4	Ring (valve side)	304 / 304
40	4	vis TH (coté robinet)	1.4301	1.4301	40	4	Screw (valve side)	304 / 304

* Sphère percée en standard
* Drilled ball as standard

**TYPES DE JOINTS
SEATS & SEALS MATERIAL**

Technical data

Caractéristiques

Versions " Chimie " :
R2S : Sièges TFM 1600
 Plage de température -50 °C / + 210 °C
R2Z : Sièges PTFE +20 % PEEK
 Plage de température 0 °C / + 280 °C
R2P : Sièges PEEK
 Plage de température 0 °C / + 280 °C

Version " Sécurité feu " :
R2H : Sièges TFM 1600
 Plage de température -50 °C / + 210 °C.
 Joint de corps spiralé inox + graphite

Versions acier au carbone et inox CF8M
 Version standard :
 Perçage boule dans la rainure pour décompression du corps.
 ATEX 94/9/CE
 Option :
 Perçage boule coté amont.
 Agréments :
 PED 97/23/CE
 TA-Luft (conformité aux émanations fugitives)
 AD Merkblatt 2000
 Matériau des sièges agréé FDA
 Options :
 Marquage π suivant la directive 2010/35/UE TPED :
 certification ADR § 1.8.7.6

"Chemical" versions:
R2S: TFM 1600 seats
 Temperature range: -50°C / +210°C
R2Z: 20% PEEK filled PTFE seats
 Temperature range: 0°C / +280°C
R2P: PEEK seats
 Temperature range: 0°C / +280°C
 "Fire Safe" version:
R2H: TFM 1600 seats
 Temperature range: -50°C / +210°C
 Seal body spiral stainless steel + graphite

Carbon steel and stainless steel CF8M
 Standard version:
 Ball drilling in the stem mark for cavity relief.
 ATEX 94/9/CE.
 Option:
 Upstream vent hole for cavity relief.
 Approvals:
 PED 97/23/CE
 TA-Luft (fugitive emissions)
 AD Merkblatt 2000
 Seat material FDA approved
 Options:
 π marking according to 2010/35/UE TPED:
 certification ADR §1.8.7.6

Courbes Pression/Température / Pressure/Temperature diagrams

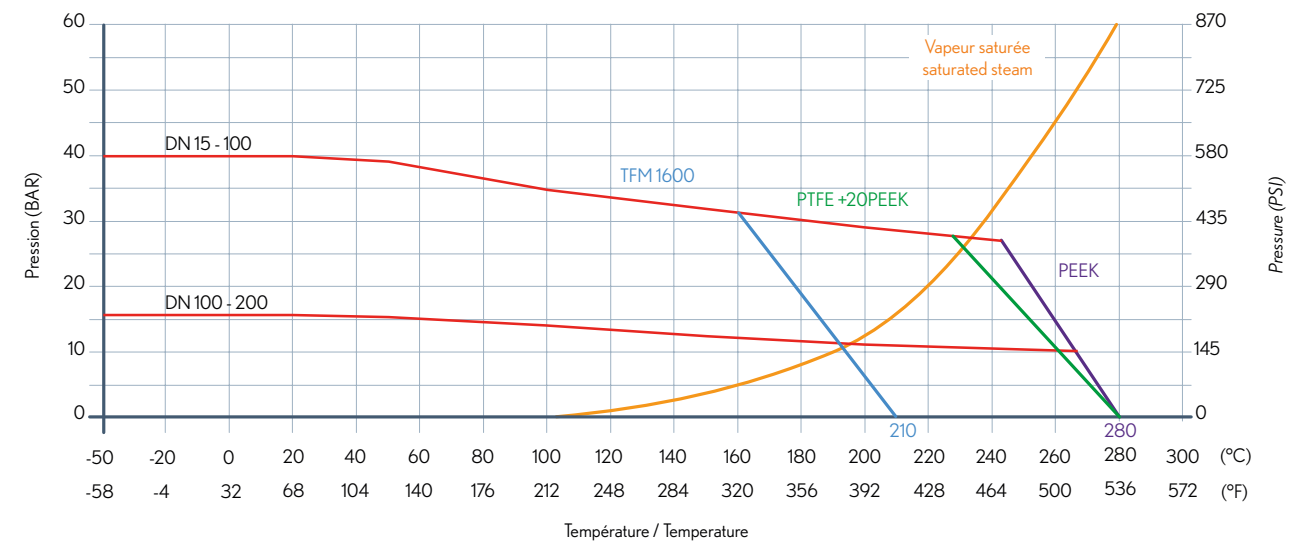

Température mini pour robinet en acier au carbone : -10 °C / 14 °F.
 Des solutions spécifiques sont disponibles pour les applications aux températures inférieures, veuillez nous consulter.

Minimum temperature for carbon steel ball valves: -10°C / 14°F
 For lower temperature, customer-specific solutions are available on request. Please contact us for more information.

**TYPES DE JOINTS
SEATS & SEALS MATERIAL**

DN 15 à 200

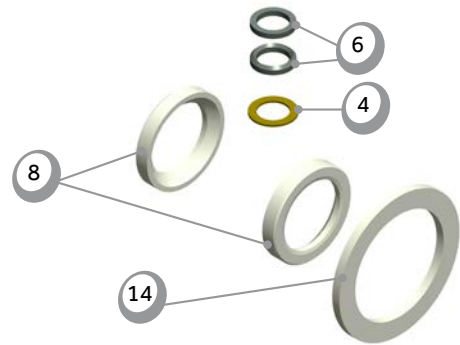

Version chimie

Chemical version

2 sièges 8
1 joint de corps 14 ou 26
1 rondelle de friction 4
1 garniture de presse-étoupe 6

Version chimie :
garniture de presse-étoupe
en 2 parties = DN 15 à 50 ou
3 parties = DN 65 à 200

Version sécurité feu :
garniture de presse-étoupe en 1 partie

Size 1/2" to 8"

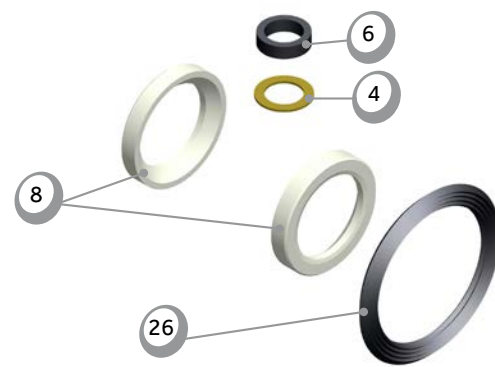

Version sécurité feu

Fire safe version

2 seats 8
1 body seat 14 or 26
1 stem thrust seat 4
1 gland-packing 6

Chemical version:
gland-packing in
2 parts = size 1/2" to 2" or
3 parts = Size 2 1/2" to 6"

Fire safe version:
gland-packing in 1 part

DN 15 à DN 50

DN 1/2" to DN 2"

Rep Item Robinet Valve type	04	06	08	14	26
R2H	PTFE 20 % PEEK 20%PEEK PTFE	Graphite Graphite	TFM 1600	-	1.4404 + Graphite 316L + Graphite
R2J	PTFE 20 % PEEK 20%PEEK PTFE	Fluorosilicone	TFM 1600	Fluorosilicone	-
R2P	PEEK	PTFE 33 % C + 2 % Gr 33%C+2%Gr PTFE	PEEK	PTFE	-
R2S	PTFE 20 % PEEK 20%PEEK PTFE	PTFE 33 % C + 2 % Gr 33%C+2%Gr PTFE	TFM 1600	PTFE	-
R2Z	PTFE 20 % PEEK 20%PEEK PTFE	PTFE 33 % C + 2 % Gr 33%C+2%Gr PTFE	PTFE 20 % PEEK 20%PEEK PTFE	PTFE	-

DN 65 à DN 200

DN 2 1/2" to DN 8"

Rep Item Robinet Valve type	04	06	08	14	26
R2H	PTFE 20 % PEEK 20%PEEK PTFE	Graphite Graphite	TFM 1600	-	1.4404 + Graphite 316L + Graphite
R2J	PTFE 20 % PEEK 20%PEEK PTFE	Fluorosilicone	TFM 1600	Fluorosilicone	-
R2S	PTFE 20 % PEEK 20%PEEK PTFE	PTFE	TFM 1600	PTFE	-
R2P	PEEK	PTFE	PEEK	PTFE	-
R2Z	PTFE 20 % PEEK 20%PEEK PTFE	PTFE	PTFE 20 % PEEK 20%PEEK PTFE	PTFE	-

**RACCORDEMENT
TYPE OF CONNECTION**

R2 DIN court

DN 15 à 50 : PN 40
Passage intégral

R2 DIN short pattern

Size 1/2" to 2" : PN 40
Full Bore

R2 DIN court

DN 65 à 100 : PN 40
DN 100 à 150 : PN 16
Passage intégral

R2 DIN short pattern

Size 2 1/2" to 4" : PN 40
Size 4" to 6" : PN 16
Full bore

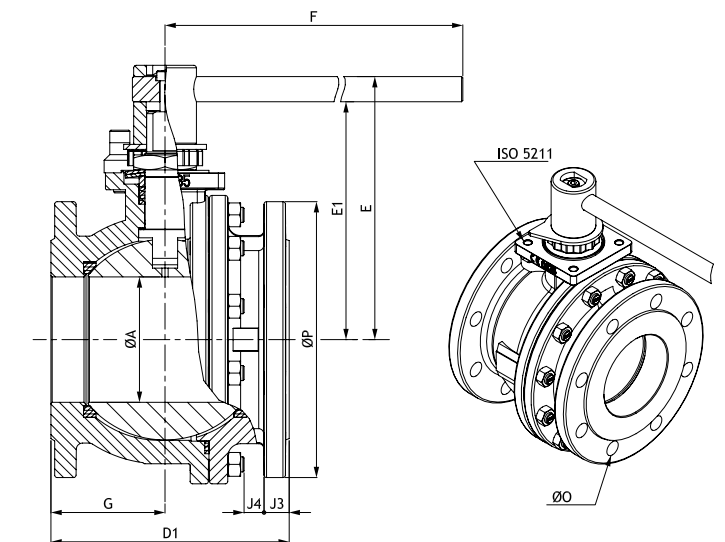
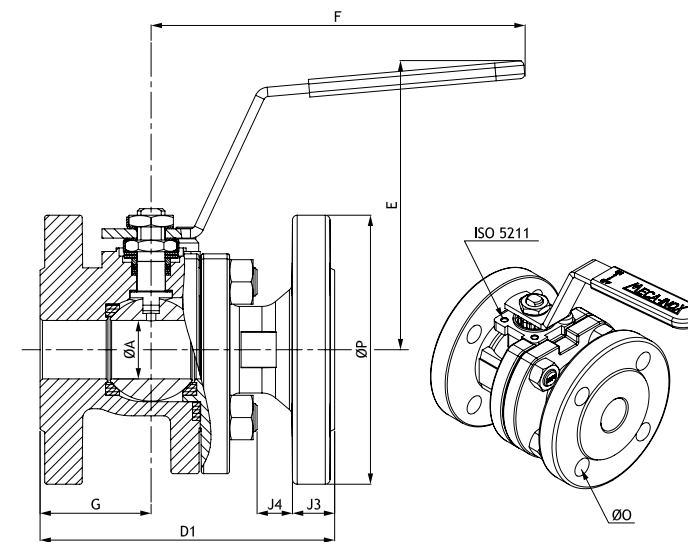

Version Court PN 40

DN Size	PN	ØA	D1	E	F	G	J3	J4	Ø0	ØP	ISO 5211	Poids (Kg) Weight (Kg)
15 1/2"	40	14	115	109	118	46	16	15.7	4xØ14 / Ø65	95	F03	2.710
20 3/4"	40	19	120	118	158	49.5	18	14	4xØ14 / Ø75	105	F04	3.880
25 1"	40	25	125	122	158	47.5	18	13.5	4xØ14 / Ø85	115	F04	5.190
32 1 1/4"	40	32	130	136	188	47	18	15.1	4xØ18 / Ø100	140	F05	7.200
40 1 1/2"	40	38	140	141	188	56	18	15.1	4xØ18 / Ø110	150	F05	8.400
50 2"	40	50	150	146	225	56.5	20	17.1	4xØ18 / Ø125	165	F07	12.455

Short pattern PN 40

DN Size	PN	ØA	D1	E	E1	F	G	J3	J4	Ø0	ØP	ISO 5211	Poids (Kg) Weight (Kg)
65 2 1/2"	40	64	170	173	155	370	67	24	21	8xØ18 / Ø145	185	F07	18.366
80 3"	40	76	180	183	165	370	76	24	21	8xØ18 / Ø160	200	F10	25.796
100 4"	40	100	190	210	190	505	81	24	19	8xØ22 / Ø190	235	F10	34.923

Version Court PN 16

DN Size	PN	ØA	D1	E	E1	F	G	J3	J4	Ø0	ØP	ISO 5211	Poids (Kg) Weight (Kg)
100 4"	16	100	190	210	190	505	91	20	18	8xØ18 / Ø180	220	F10	31.450
150 6"	16	150	350	270	242	700	129	22	-	8xØ22 / Ø240	285	F12	75.000

Short pattern PN 16

2-PCS

RACCORDEMENT
TYPE OF CONNECTION

R2 DIN court

DN 150 à 200 : PN 16
Passage intégral

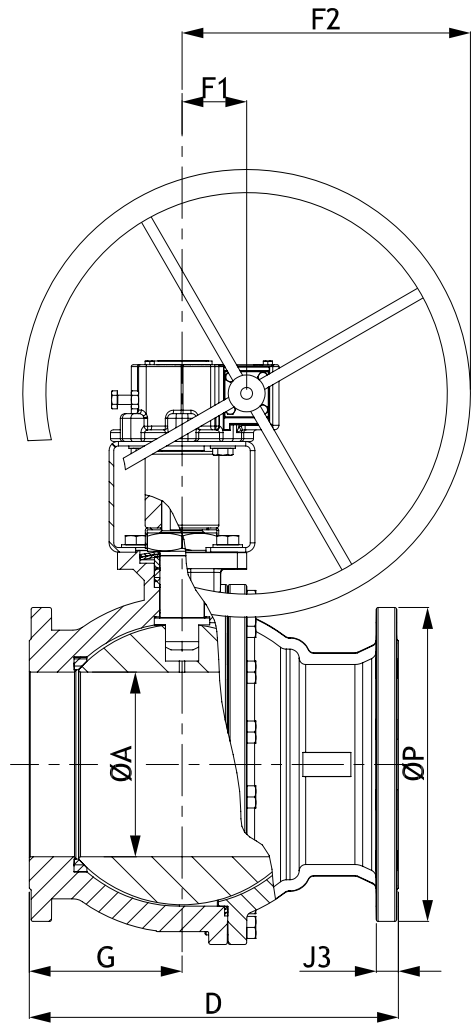

R2 DIN short pattern

Size 6" to 8" : PN 16
Full Bore

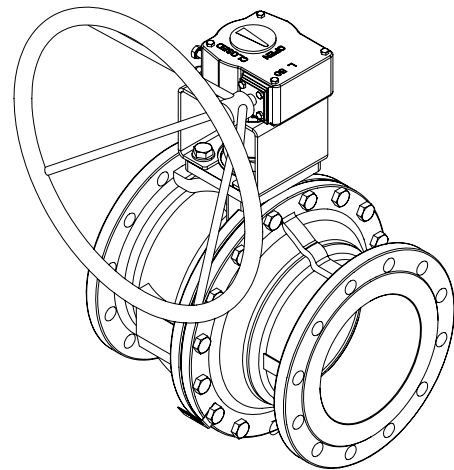
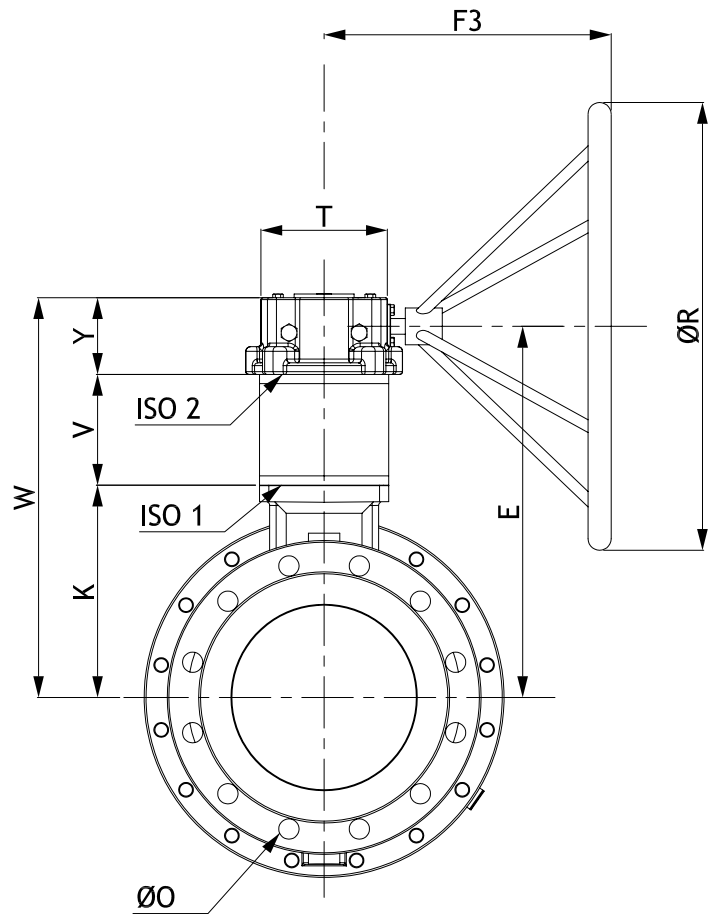

DN Size	PN	ØA	D	K	E	F1	F2	F3	G	J3	Ø0	ØP	T	ISO 1 5211	ISO 2 5211	V	ØR	W	Y	Poids (Kg) Weight (Kg)	
150	6"	16	150	350	180	330	70	312.5	310	129	22	8 x Ø22 / Ø240	285	140	F12	F12	99.5	485	363	83	86.000
200	8"	16	200	400	230	400	70	312.5	310	165.5	24	12 x Ø22 / Ø295	340	140	F14	F12	120	485	433	83	135.000

RACCORDEMENT
TYPE OF CONNECTION

R2 DIN long

DN 15 à 50 : PN 40
Passage intégral

R2 DIN long pattern

Size 1/2" to 2" : PN 40
Full bore

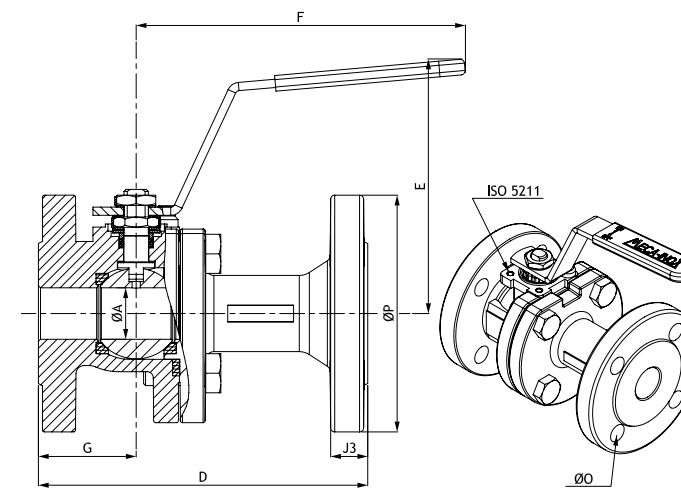

R2 DIN long

DN 65 à 100 : PN 40
DN 100 : PN 16
Passage intégral

R2 DIN long pattern

Size 2" 1/2 to 4" : PN 40
Size 4" : PN 16
Full bore

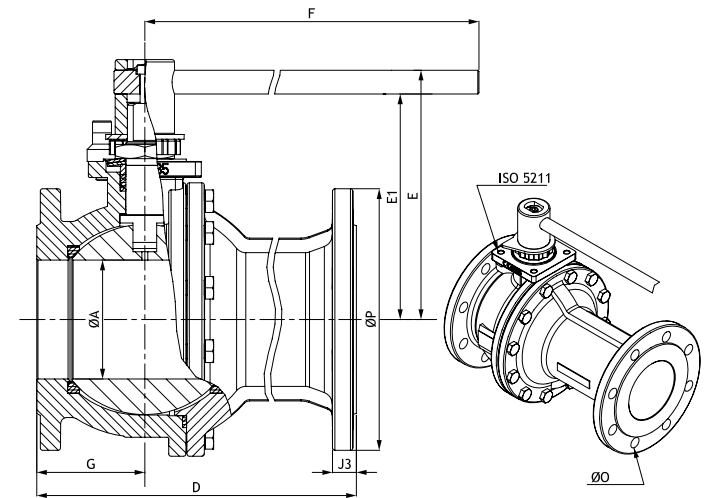

Version Long PN 40

DN Size	PN	ØA	D	E	F	G	J3	Ø0	ØP	ISO 5211	Poids (Kg) Weight (Kg)
15	1/2"	40	14	130	109	118	46	16	4xØ14 / Ø65	F03	2.770
20	3/4"	40	19	150	118	158	49.5	18	4xØ14 / Ø75	F04	4.200
25	1"	40	25	160	122	158	47.5	18	4xØ14 / Ø85	F04	5.230
32	1" 1/4	40	32	180	136	188	47	18	4xØ18 / Ø100	F05	7.650
40	1" 1/2	40	38	200	141	188	56	18	4xØ18 / Ø110	F05	8.935
50	2"	40	50	230	146	225	56.5	20	4xØ18 / Ø125	F07	13.355

Long pattern PN 40

DN Size	PN	ØA	D	E	E1	F	G	J3	Ø0	ØP	ISO 5211	Poids (Kg) Weight (Kg)
65	2" 1/2	40	64	290	173	155	370	67	8xØ18 / Ø145	185	F07	19.453
80	3"	40	76	310	183	165	370	76	8xØ18 / Ø160	200	F10	27.361
100	4"	40	100	350	210	190	505	81	8xØ22 / Ø190	235	F10	37.360

Version Long PN 16

DN Size	PN	ØA	D	E	E1	F	G	J3	Ø0	ØP	ISO 5211	Poids (Kg) Weight (Kg)
100	4"	16	100	350	210	190	505	81	8xØ18 / Ø180	220	F10	35.790

2-PCS

**MOTORISATION PNEUMATIQUE
PNEUMATIC ACTUATION**

Nomenclature R2 Motorisée

DN 15 à 50

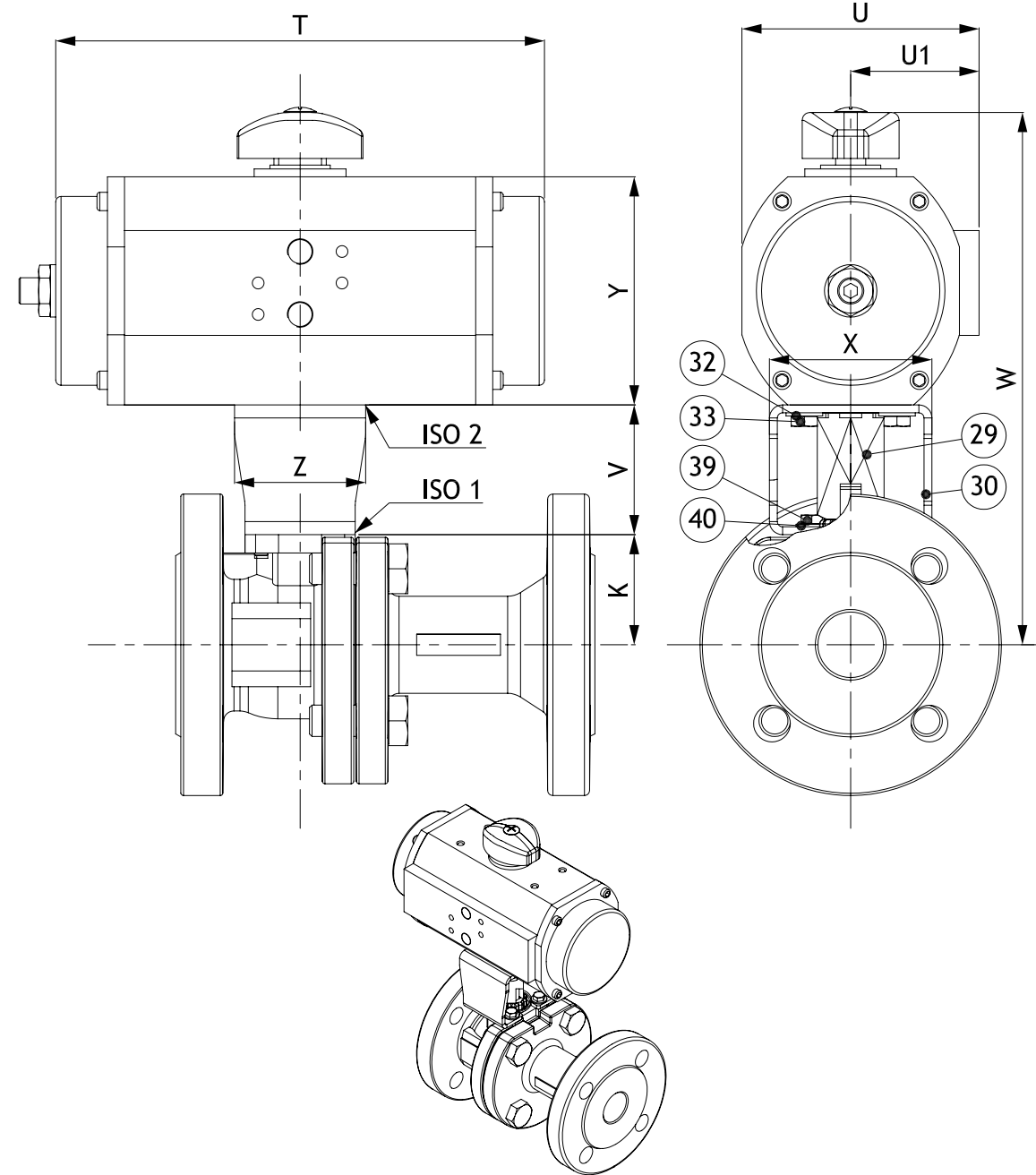

R2 actuated components

Size 1/2" to 2"

DN 15 à 50

Size 1/2" to 2"

N°	Nb	Description	Matière (EN)
29	1	Entraîneur	1.4307
30	1	Arcade	1.4307
32	4	Rondelle plate coté actionneur	1.4301
33	4	Vis TH coté actionneur	1.4301
39	4	Vis TH coté robinet	1.4301
40	4	Rondelle plate coté robinet	1.4301

Item	Qty	Description	Material (ASTM)
29	1	Coupling	304L
30	1	Bracket	304L
32	4	Ring (actuator side)	304
33	4	Screw (actuator side)	304
39	4	Screw (valve side)	304
40	4	Ring (valve side)	304

**MOTORISATION PNEUMATIQUE
PNEUMATIC ACTUATION**

R2S/R2H Motorisée

DN 15 à 50

R2S/R2H actuated

Size 1/2" to 2"

Modèle TRUTORQ Simple Effet sur R2S/R2H Spring Return TRUTORQ type on R2S/R2H

DN Size	K	ISO 1	TRUTORQ	ISO 2	T	U	U1	V	W	X	Y	Z
15	1/2"	F03	TSR003	F04	149.5	69.5	38	47	168	52	70	42
20	3/4"	F04	TSR005	F05	186.5	90.5	49	49.5	194.4	52	87	42
25	1"	F04	TSR008	F05	186.5	90.5	49	49.5	198.5	62	87	50
32	1 1/4"	F05	TSR008	F05	162	105	57	49.5	232.5	62	109	50
40	1 1/2"	F05	TSR012	F07	194	121	67	49.5	247	82	118.5	69
50	2"	F07	TSR012	F07	194	121	67	79.5	301	85	118.5	69

Données pour pression de service à : ΔP 7 bars max. et 6 bars d'air comprimé / Values given for service pressure at: ΔP 7 bars max. and 6 bars air supply.

Modèle TRUTORQ Double Effet sur R2S/R2H Double Acting TRUTORQ type on R2S/R2H

DN Size	K	ISO 1	TRUTORQ	ISO 2	T	U	U1	V	W	X	Y	Z
15	1/2"	F03	TDA003	F04	149.5	69.5	38	47	168	52	70	36
20	3/4"	F04	TDA003	F04	149.5	69.5	38	49.5	177.4	52	70	42
25	1"	F04	TDA003	F04	149.5	69.5	38	49.5	181.5	52	70	42
32	1 1/4"	F05	TDA005	F05	186.5	90.5	49	49.5	210.5	62	87	50
40	1 1/2"	F05	TDA005	F05	186.5	90.5	49	49.5	215.5	62	87	50
50	2"	F07	TDA005	F05	186.5	90.5	49	79.5	269.5	85	87	69

Données pour pression de service à : ΔP 7 bars max. et 6 bars d'air comprimé / Values given for service pressure at: ΔP 7 bars max. and 6 bars air supply.

R2S/R2H ΔP: 7 bars

DN	Air Moteur (Bar)	Double Effet Double acting Code	Simple Effet Spring return Code
15 F03	6	KPNI410 0411 2TDA003	KPNI410 0411 2TSR003 N66
20 F04	6	KPNI420 0411 2TDA003	KPNI420 0514 2TSR005 N66
25 F04	6	KPNI420 0411 2TDA003	KPNI420 0514 2TSR008 N44
32 F05	6	KPNI432 0514 2TDA005	KPNI432 0514 2TSR008 N44
40 F05	6	KPNI432 0514 2TDA005	KPNI432 0717 2TSR012 N44
50 F07	6	KPNI450 0514 2TDA005	KPNI450 0717 2TSR012 N44

MOTORISATION PNEUMATIQUE
PNEUMATIC ACTUATION

R2Z Motorisée

DN 15 à 50

R2Z actuated

Size 1/2" to 2"

Modèle TRUTORQ Simple Effet sur R2Z *Spring Return TRUTORQ type on R2Z*

DN Size	K	ISO 1	TRUTORQ	ISO 2	T	U	U1	V	W	X	Y	Z
15	1/2"	F03	TSR005	F05	186.5	90.5	38	47	185	62	87	50
20	3/4"	F04	TSR008	F05	162	105	57	49.5	216.4	62	109	50
25	1"	F04	TSR008	F05	162	109	57	49.5	220.5	62	109	50
32	1 1/4"	F05	TSR012	F07	194	121	67	49.5	242	82	118.5	69
40	1 1/2"	F05	TSR012	F07	194	121	67	49.5	247	82	118.5	69
50	2"	F07	TSR020	F07	218	136.5	72	79.5	323	82	140.5	69

Données pour pression de service à : ΔP 7 bars max. et 6 bars d'air comprimé / Values given for service pressure at: ΔP 7 bars max. and 6 bars air supply.

Modèle TRUTORQ Double Effet sur R2Z *Double Acting TRUTORQ type on R2Z*

DN Size	K	ISO 1	TRUTORQ	ISO 2	T	U	U1	V	W	X	Y	Z
15	1/2"	F03	TDA003	F04	149.5	69.5	38	47	168	52	70	36
20	3/4"	F04	TDA003	F04	149.5	69.5	38	49.5	177.4	52	70	42
25	1"	F04	TDA005	F05	186.5	90.5	49	49.5	198.5	62	87	50
32	1 1/4"	F05	TDA005	F05	186.5	90.5	49	49.5	210.5	62	87	50
40	1 1/2"	F05	TDA005	F05	186.5	90.5	49	49.5	215.5	62	87	50
50	2"	F07	TDA005	F05	186.5	90.5	49	79.5	269.5	85	87	69

Données pour pression de service à : ΔP 7 bars max. et 6 bars d'air comprimé / Values given for service pressure at: ΔP 7 bars max. and 6 bars air supply.

R2Z ΔP: 7 bars

DN	Air Moteur (Bar)	Double Effet Double acting Code	Simple Effet Spring return Code
15 F03	6	KPNI410 0411 2TDA003	KPNI410 0514 2TSR005 N66
20 F04	6	KPNI420 0411 2TDA003	KPNI420 0514 2TSR008 N44
25 F04	6	KPNI420 0514 2TDA005	KPNI420 0514 2TSR008 N44
32 F05	6	KPNI432 0514 2TDA005	KPNI432 0717 2TSR012 N44
40 F05	6	KPNI432 0514 2TDA005	KPNI432 0717 2TSR012 N44
50 F07	6	KPNI450 0514 2TDA005	KPNI450 0717 2TSR020 N44

MOTORISATION PNEUMATIQUE
PNEUMATIC ACTUATION

Nomenclature R2 Motorisée

DN 65 à 200

R2 actuated components

Size 2" 1/2 to 8"

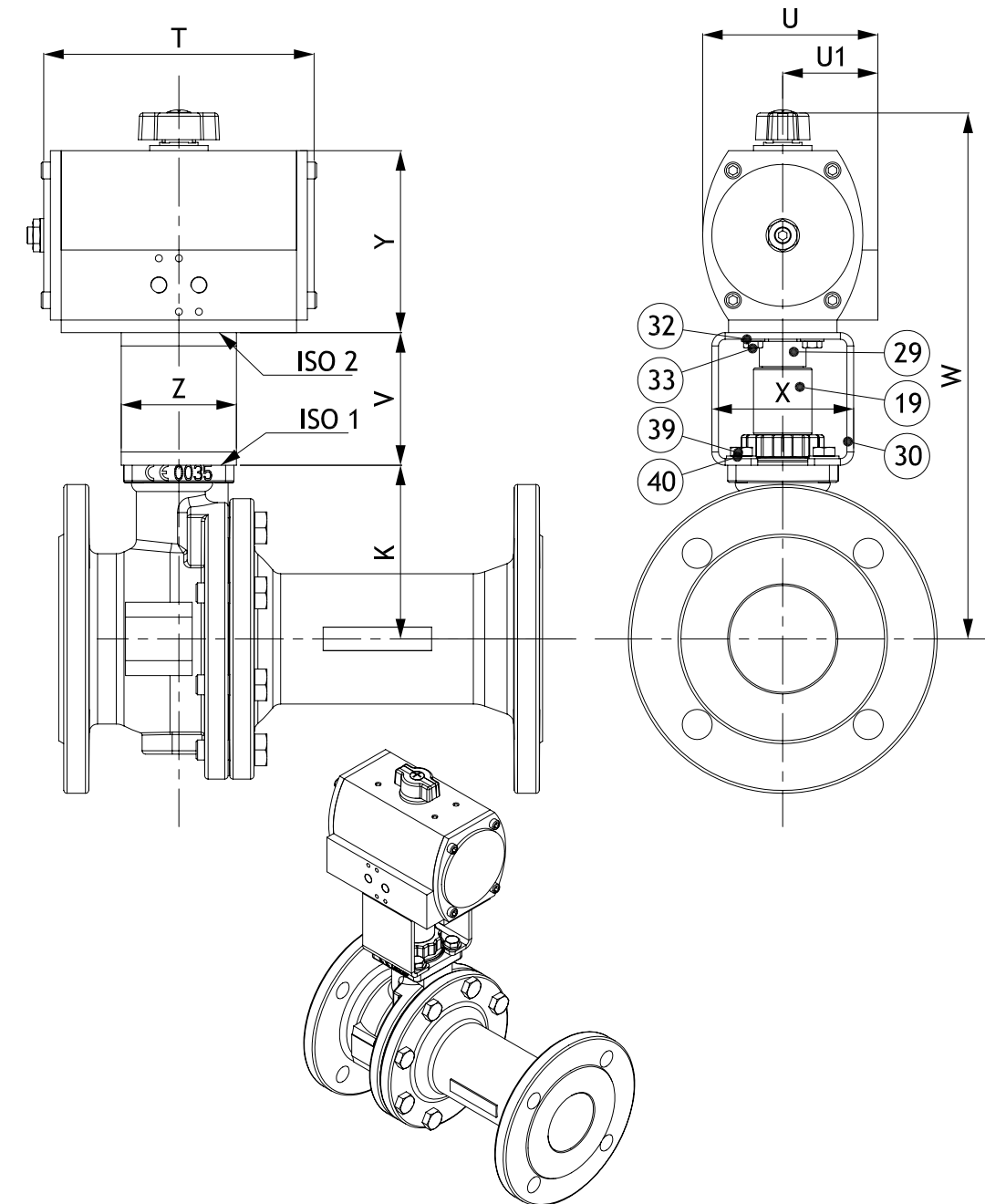

DN 65 à 200

N°	Nb	Description	Matière (EN)
19	1	Noix de manœuvre	1.4305
29	1	Entraîneur	1.4307
30	1	Arcade	1.4307
32	4	Rondelle plate coté actionneur	1.4301
33	4	Vis TH coté actionneur	1.4301
39	4	Vis TH coté robinet	1.4301
40	4	Rondelle plate coté robinet	1.4301

DN 2" 1/2 to 8"

Item	Qty	Description	Material (ASTM)
19	1	Handle adaptator	303
29	1	Coupling	304L
30	1	Bracket	304L
32	4	Ring (actuator side)	304
33	4	Screw (actuator side)	304
39	4	Screw (valve side)	304
40	4	Ring (valve side)	304

2-PCS

MOTORISATION PNEUMATIQUE PNEUMATIC ACTUATION

R2S/R2H Motorisée

DN 65 à 200

R2S/R2H actuated

Size 2" 1/2 to 8"

Modèle TRUTORQ Simple Effet sur R2S/R2H *Spring Return TRUTORQ type on R2S/R2H*

DN Size	K	ISO 1	TRUTORQ	ISO 2	T	U	U1	V	W	X	Y	Z	
65	2"1/2	104	F07	TSR035	F10	266	156	78	79.5	370	120	166.5	105
80	3"	114	F10	TSR035	F10	266	156	78	79.5	380	120	166.5	95
100	4"	133	F10	TSR035	F10	266	156	78	79.5	399	120	166.5	95
150	6"	180	F12	TSR100	F14	361	227	113.5	99.5	559.5	158	250	140
200	8"	230	F14	TSR150	F14	390	280	140	120	680	158	300	140

Données pour pression de service à : ΔP 7 bars max. et 6 bars d'air comprimé / Values given for service pressure at: ΔP 7 bars max. and 6 bars air supply.

Modèle TRUTORQ Double Effet sur R2S/R2H *Double Acting TRUTORQ type on R2S/R2H*

DN Size	K	ISO 1	TRUTORQ	ISO 2	T	U	U1	V	W	X	Y	Z	
65	2"1/2	104	F07	TDA008	F07	162	105	57	79.5	312.5	85	109	69
80	3"	114	F10	TDA008	F07	162	105	57	79.5	322.5	120	109	105
100	4"	133	F10	TDA012	F07	194	121	67	79.5	351	120	118.5	105
150	6"	180	F12	TDA055	F12	312	191	95.5	99.5	507	144	207.5	118
200	8"	230	F14	TDA055	F12	312	191	95.5	120	577.5	144	207.5	118

Données pour pression de service à : ΔP 7 bars max. et 6 bars d'air comprimé / Values given for service pressure at: ΔP 7 bars max. and 6 bars air supply.

R2S/R2H ΔP : 7 bars

DN	Air Moteur (Bar)	Double Effet Double acting Code	Simple Effet Spring return Code
65 F07	6	KPNI2P065 0714 2TDA008	KPNI2P065 1022 2TSR035 N44
80 F10	6	KPNI2P080 0714 2TDA008	KPNI2P080 1022 2TSR035 N44
100 F10	6	KPNI2P100 0717 2TDA012	KPNI2P100 1022 2TSR035 N44
150 F12	6	KPNI2P125 1227 2TDA055	KPNI2P125 1436 2TSR100 N44
200 F14	6	KPNI2P200 1227 2TDA055	KPNI2P200 1436 2TSR150 N44

MOTORISATION PNEUMATIQUE PNEUMATIC ACTUATION

R2Z Motorisée

DN 65 à 150

R2Z actuated

Size 2" 1/2 to 6"

Modèle TRUTORQ Simple Effet sur R2Z *Spring Return TRUTORQ type on R2Z*

DN Size	K	ISO 1	TRUTORQ	ISO 2	T	U	U1	V	W	X	Y	Z	
65	2"1/2	104	F07	TSR035	F10	266	156	78	79.5	370	120	166.5	105
80	3"	114	F10	TSR035	F10	266	156	78	79.5	380	120	166.5	95
100	4"	133	F10	TSR035	F10	266	156	78	79.5	399	120	166.5	95
150	6"	180	F12	TSR150	F14	390	280	140	99.5	609.5	158	300	140

Données pour pression de service à : ΔP 7 bars max. et 6 bars d'air comprimé / Values given for service pressure at: ΔP 7 bars max. and 6 bars air supply.

Modèle TRUTORQ Double Effet sur R2Z *Double Acting TRUTORQ type on R2Z*

DN Size	K	ISO 1	TRUTORQ	ISO 2	T	U	U1	V	W	X	Y	Z	
65	2"1/2	104	F07	TDA008	F07	162	105	57	79.5	312.5	85	109	69
80	3"	114	F10	TDA012	F07	194	121	67	79.5	332	120	118.5	105
100	4"	133	F10	TDA012	F07	194	121	67	79.5	351	120	118.5	105
150	6"	180	F12	TDA055	F12	312	191	95.5	99.5	507	144	207.5	118

Données pour pression de service à : ΔP 7 bars max. et 6 bars d'air comprimé / Values given for service pressure at: ΔP 7 bars max. and 6 bars air supply.

R2Z ΔP : 7 bars

DN	Air Moteur (Bar)	Double Effet Double acting Code	Simple Effet Spring return Code
65 F07	6	KPNI2P065 0714 2TDA008	KPNI2P065 1022 2TSR035 N44
80 F10	6	KPNI2P080 0717 2TDA012	KPNI2P080 1022 2TSR035 N44
100 F10	6	KPNI2P100 0717 2TDA012	KPNI2P100 1022 2TSR035 N44
150 F12	6	KPNI2P125 1227 2TDA055	KPNI2P125 1436 2TSR150 N44

DN 08 à 200

- Vanne fluide propre
- Vanne usinée
- Vanne v-ball
- Vanne fond de cuve
- Vanne prise échantillon
- Vanne isolement & purge
- Vanne enveloppe thermique
- Clapet, viseur, filtre
- Vanne économique



Vanne sanitaire
Sanitary valve

Size 1/4" to 8"

- Clean fluid valve*
- Machined valve*
- V-ball valve*
- Tank bottom valve*
- Sampling ball valve*
- Double block and bleed*
- Steam jacketed valve*
- Check valve, sight glass, filter*
- Economic valve*



Vanne isolement & purge
Double block and bleed



Vanne prise échantillon
Sampling ball valve



Fond de Cuve
Tank bottom valve

VANNE FLUIDE PROPRE
CLEAN FLUID VALVE

PN4 | Soudure orbitale

DN 08 à 50

PN4 | Orbital welding

Size 1/4" to 2"



En standard :
Passage intégral
Tube ISO
Levier inox cadennassable
Boule & embouts en Ra 0,4 µm

Sur demande :
Nettoyé et conditionné en sachet plastique individuel
Entretoise en inox
Autres dimensions
Embouts en 1.4435 (bas taux de ferrite)
Version "true bore" (passage total)

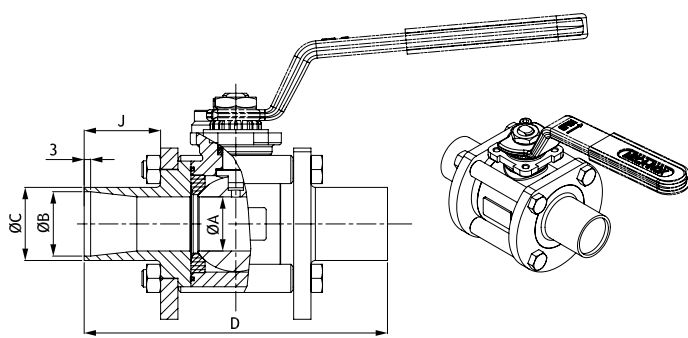

PN4 | Soudure orbitale

DN 65 à 150

PN4 | Orbital welding

Size 2"1/2 to 6"

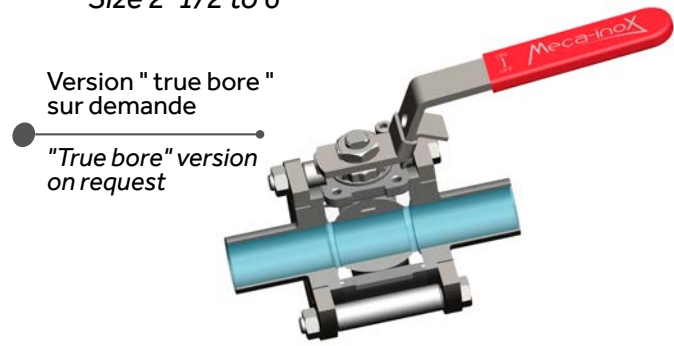

Version "true bore" sur demande
"True bore" version on request

Standard:
Full bore
ISO pipe
Stainless steel lockable handle
Ball & ends polished inside to surface finishing 0,4µm

On request:
Cleaned and packed in individual plastic bag
Distance piece in stainless steel
Other sizes available
Ends in 1.4435 (BN2 low ferrite)
"True bore" version

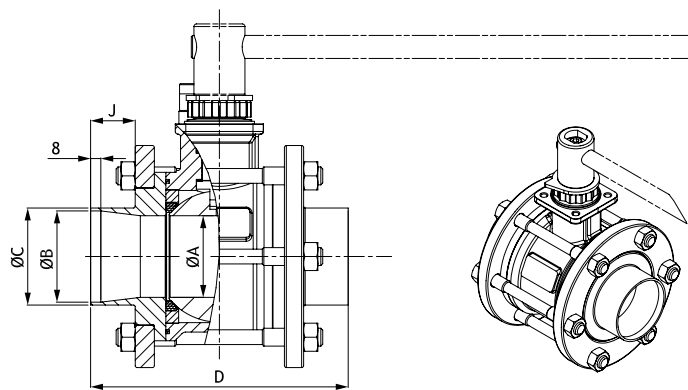

DN Size	PN	Ø A	Ø B (ISO)	Ø C Std	D	J	
65	2"1/2	40	64	70.3	76.1	202	35
80	3"	40	76	83.1	88.9	228	35
100	4"	25	100	107.9	114.3	256	35
125	5"	25	125	133.7	139.7	291	35
150	6"	16	150	162.3	168.3	323	35

VANNE USINÉE
MACHINED BALL VALVE

MS4 | MY4 | A souder en bout BW

DN 08 à 50

MS4 | MY4 | Butt Weld ends BW

Size 1/4" to 2"



MS4 avec embouts libres à soudure orbitale

MS4 with loose end orbital welding

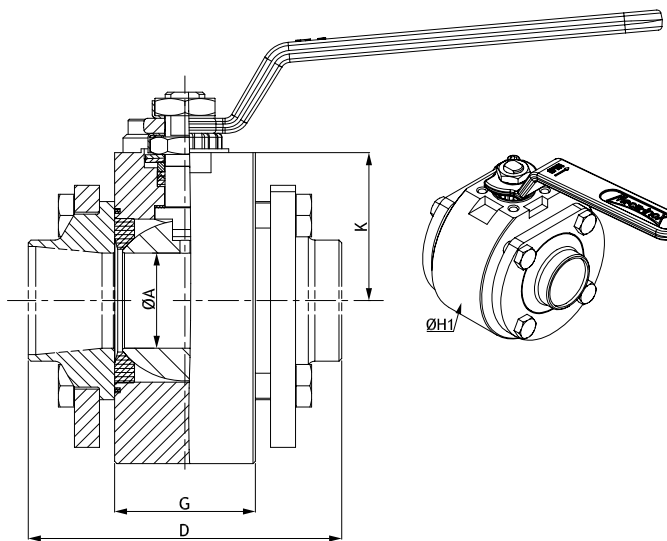

DN Size	Ø A	D	G	ØH1	K	
08/10	1/4 - 3/8"	11.1	70	24.4	65	31
15	1/2"	14	70	24.4	65	31
20	3/4"	19	85	31.6	85	37.9
25	1"	25	100	41.4	95	42
32	1"1/4	32	110	48.2	120	54
40	1"1/2	38	125	56.2	130	59
50	2"	50	150	71	160	73

MS4 | MY4 | A souder en bout BW

DN 65 à 100

MS4 | MY4 | Butt Weld ends BW

Size 2"1/2 to 4"



MY4 certifié DNV avec embouts fixes

MY4 CY DNV certified with fixed end

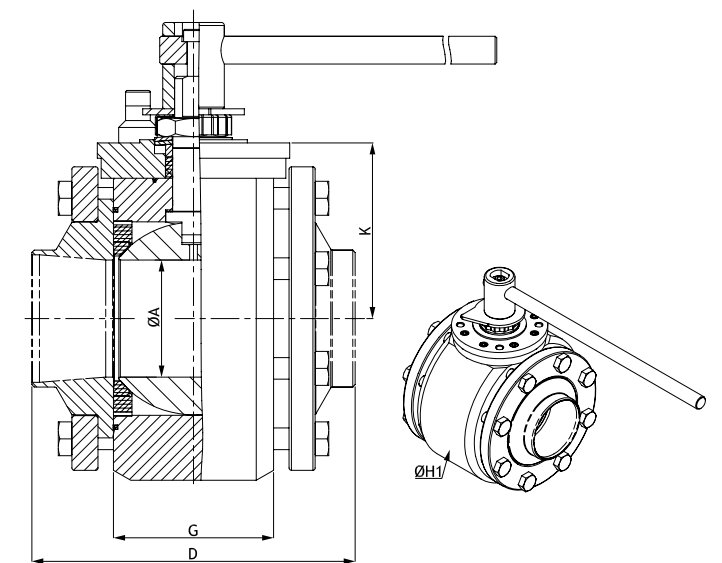

DN Size	Ø A	D	G	ØH1	K	
65	2"1/2	64	180	84	190	104
80	3"	76	210	104	210	114
100	4"	100	230	130	265	133

Sur demande

Version Cryogénie avec certification DNV (MY4 CY)
Rules for steel Ships January 2011 Part 5, Chap.5.sect.6-C800.
Embouts fixes
Autres matériaux
Autres types de raccordement

On request

Cryogenic version with DNV certification (MY4 CY)
Rules for steel Ships January 2011 Part 5, Chap.5.sect.6-C800.
Fixed end
Other materials
Other type of connections

**VANNE V-BALL
V-BALL VALVE**

PZ4 V-BALL | DN 15 à 50

Sièges PTFE + 20 % PEEK

PZ4 V-BALL | Size 1/2" to 2"

20% PEEK PTFE seats

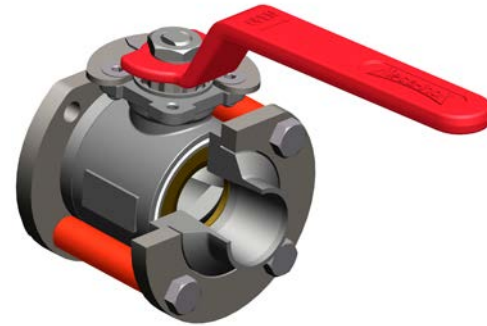

Courbes des débits (Kv en m³/h) en fonction de l'ouverture de la vanne
Flow rate diagrams: KV (m³/h) versus opening angle

Exemple de lecture : robinet DN 25, boisseau en V 60°, ouverture à 50°, Kv = 2,87 m³/h
Reading example: valve 1", V60 ball port, opening angle 50°, Kv = 2,87 m³/h

DN Size	Type de boule Ball type	Débit (Kv en m ³ /h) par degré d'ouverture / Flow rate (Kv m ³ /h) per degree of rotation																	
		5°	10°	15°	20°	25°	30°	35°	40°	45°	50°	55°	60°	65°	70°	75°	80°	85°	90°
15	standard	0.00	0.00	0.00	0.12	0.31	0.54	0.81	1.16	1.60	2.14	2.82	3.80	5.09	7.00	10.05	12.18	14.19	15.67
	V60	0.00	0.00	0.00	0.00	0.03	0.11	0.22	0.37	0.57	0.83	1.15	1.57	2.12	2.84	3.70	4.65	5.64	6.19
	V30	0.00	0.00	0.00	0.00	0.02	0.06	0.13	0.22	0.33	0.47	0.64	0.84	1.09	1.38	1.71	2.05	2.42	2.55
20	standard	0.00	0.00	0.00	0.10	0.39	0.76	1.23	1.84	2.62	3.54	4.86	6.52	8.78	12.64	16.57	23.22	27.71	31.55
	V60	0.00	0.00	0.00	0.01	0.04	0.17	0.35	0.62	0.99	1.46	2.07	2.85	3.86	5.15	6.79	8.60	10.46	11.23
	V30	0.00	0.00	0.00	0.00	0.02	0.09	0.20	0.35	0.56	0.81	1.12	1.50	1.94	2.46	3.06	3.71	4.39	4.71
25	standard	0.00	0.00	0.00	0.39	0.95	1.62	2.49	3.60	4.94	6.59	8.86	11.90	15.96	21.51	29.40	41.17	49.22	53.48
	V60	0.00	0.00	0.00	0.05	0.16	0.42	0.80	1.32	1.99	2.87	3.97	5.34	7.07	9.31	12.11	15.29	18.37	20.10
	V30	0.00	0.00	0.00	0.01	0.08	0.23	0.45	0.74	1.11	1.56	2.11	2.77	3.54	4.44	5.43	6.60	7.69	8.60
40	standard	0.00	0.00	0.80	1.60	2.95	4.58	6.61	8.95	12.20	16.30	22.13	28.71	37.62	50.81	69.54	99.93	119.26	132.37
	V60	0.00	0.00	0.05	0.25	0.71	1.41	2.39	3.74	5.46	7.54	10.12	13.33	17.23	22.10	28.11	35.38	42.13	44.70
	V30	0.00	0.00	0.00	0.12	0.38	0.77	1.31	2.02	2.89	3.96	5.53	6.76	8.52	10.50	12.75	15.17	17.56	19.01
50	standard	0.00	0.00	1.20	3.08	5.50	8.45	12.17	16.63	22.04	28.98	38.83	50.96	67.51	89.82	124.96	172.06	209.85	231.05
	V60	0.00	0.00	0.10	0.55	1.40	2.63	4.33	6.55	9.33	12.76	17.00	22.20	28.84	36.73	47.18	58.42	68.75	76.51
	V30	0.00	0.00	0.10	0.31	0.80	1.51	2.45	3.65	5.11	6.96	9.05	11.53	14.49	17.87	21.76	25.93	29.92	31.90

Courbes des débits (Kv en m³/h) en fonction de l'ouverture de la vanne
Flow rate diagrams: KV (m³/h) versus opening angle

Exemple : robinet DN 25 Example: valve size 1"

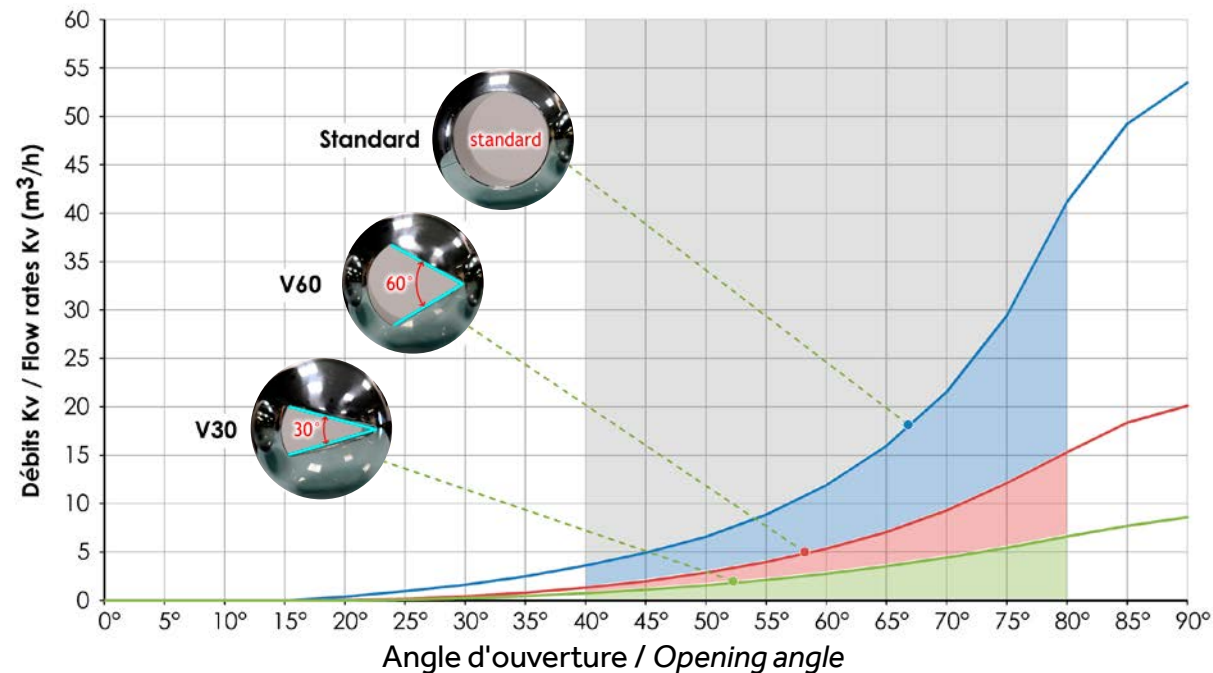

**VANNE FOND DE CUVE
TANK BOTTOM VALVE**

PS4 FC | Vanne fond de cuve

DN 10 à 25

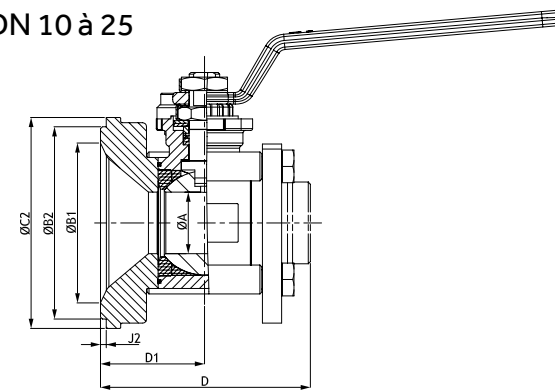

PS4 FC | Tank bottom valve

Size 3/8" to 1"

DN Size	ØA	ØB1	ØB2	ØC2	D	D1	J2
08/10 3/8"	11.1	43	54.8	64.5	65	32.5	3
15 1/2"	14	50	64.8	74.5	69.5	34.5	3
20 3/4"	19	63	74.8	84.5	82.5	40	3
25 1"	25	71	84.8	94.5	95	45	3

PS4 FCSZ | Vanne fond de cuve sans zone de rétention

DN 32 à 50

Équipé en standard de 1/2 Coquilles

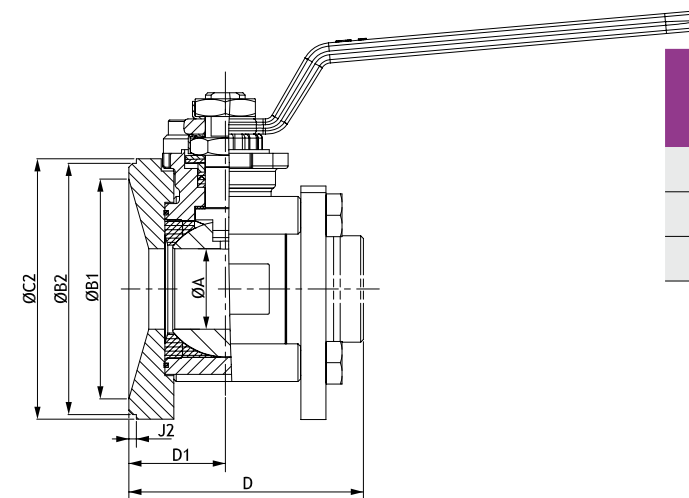

PS4 FCSZ | Tank bottom valve without retention area

Size 1 1/4 to 2"

Valve mounted with cavity fillers

DN Size	ØA	ØB1	ØB2	ØC2	D	D1	J2
32 1 1/4"	32	87.5	100	103.7	93.4	38.4	3
40 1 1/2"	38	98	110	117	99.5	42.4	4
50 2"	50	126	138	148	124.5	49.5	6

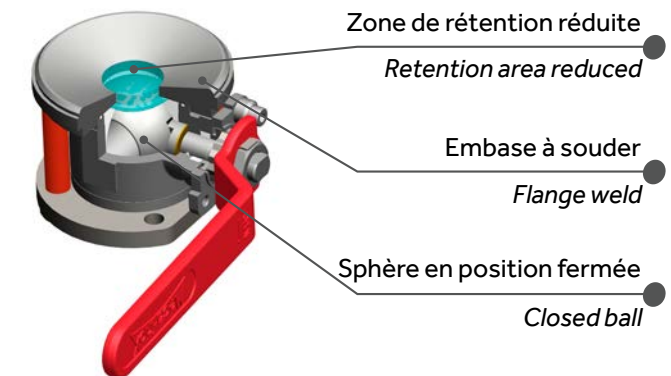

DN 65 à 100

Équipé en standard de 1/2 Coquilles

Size 2 1/2 to 4"

Valve mounted with cavity fillers

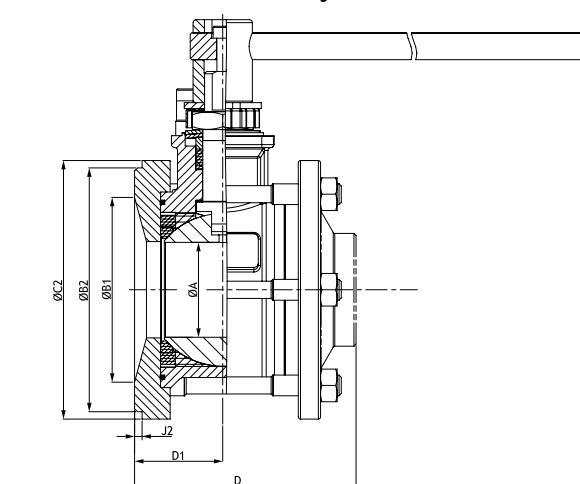

Une vanne PS4 FCSZ présente un volume de rétention 10 fois moins important qu'une vanne classique avec raccord clamp et piquage sur le fond de la cuve. Exemple : pour un DN de sortie = 32 mm, le volume de rétention n'est que de 4 ml.

The volume retention of a PS4 FCSZ valve is 10 times smaller than a standard valve with tank bottom T piping. Example: the DN 32 volume retention is only 4 ml.

DN Size	ØA	ØB1	ØB2	ØC2	D	D1	J2
65 2 1/2"	64	125	164.5	174.5	149.5	59.5	5
80 3"	76	167	190	198	170	65	4
100 4"	100	180	227	237	194	79	5

**VANNE AFFLEURANTE
FLUSH BALL VALVE**

Pour tube DN 80 à 200

Position horizontale ou verticale

Robinet avec embase à souder sur canalisation de 80 à 200 mm. Une simple découpe sur la canalisation ou sur la virole permet d'insérer l'embase qui, après soudure, fera partie intégrante de la canalisation ou du réservoir.

Le volume de rétention du PS4 DR est 7 fois plus réduite qu'une vanne classique avec raccord clamp et piquage sur la canalisation.

Exemple: pour un DN de sortie = 25 mm, le volume de rétention (vanne fermée) n'est que de 6 ml.

For pipe size 3" to 8"

Horizontal or vertical position

The PS4 DR design includes flange for direct pipe welding. It allows fitting to production lines from 80 to 200mm.

The volume retention of a PS4 DR valve 12 times smaller than a standard valve with clamp fitting and T piping.

Example: the DN 25 volume retention is only 6ml.

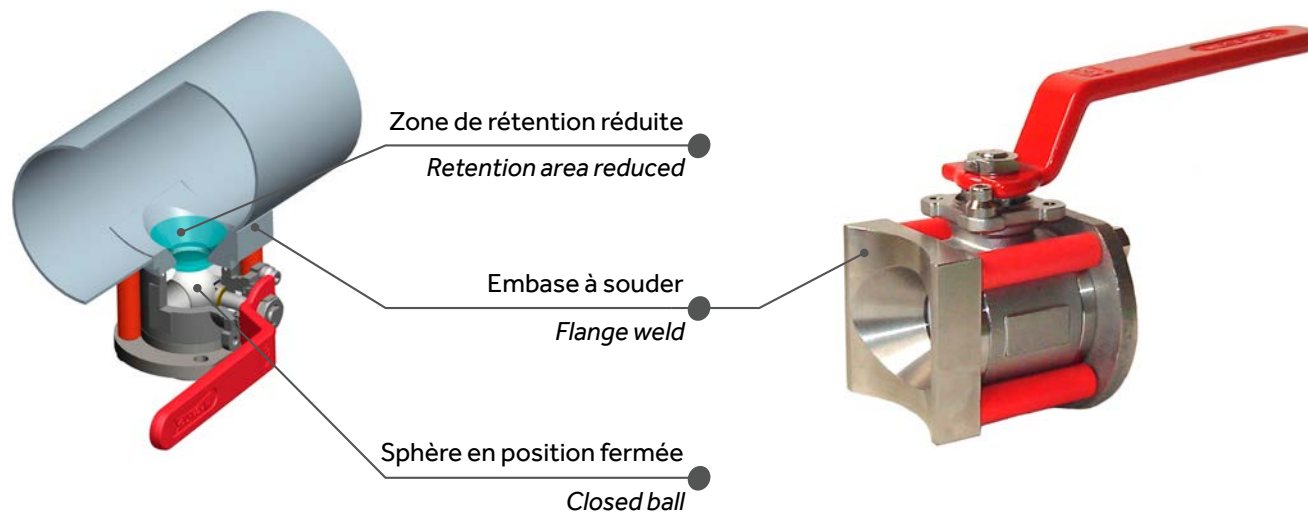
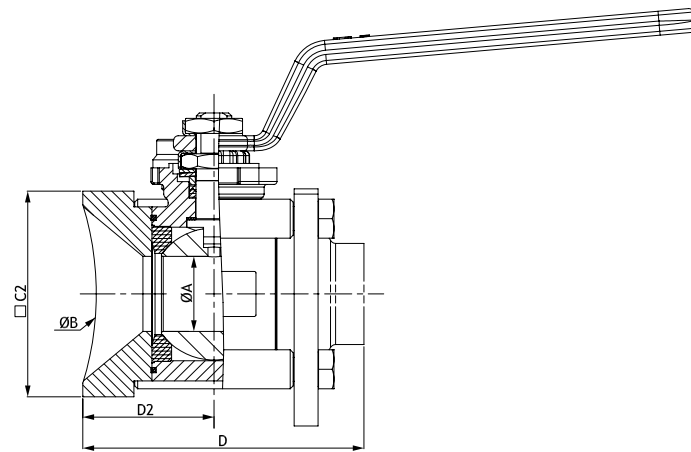

DN Size	ØA	ØB	Ø Canalisation				□C2	D	D2	
25	1"	25	100	80	100	125	150	68.5	93.7	43.7
25	1"	25	200	200				68.5	93.7	43.7

**VANNE AFFLEURANTE
FLUSH BALL VALVE**

Version 2 voies

Dimensions de tube sur demande

2-way version

Pipe dimension on request

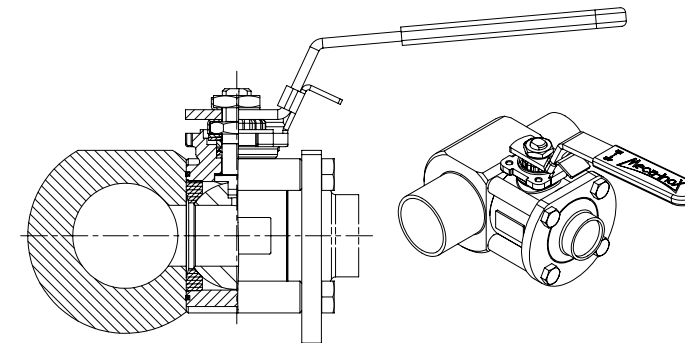

Version 3 voies

Dimensions de tube sur demande

3-way version

Pipe dimension on request

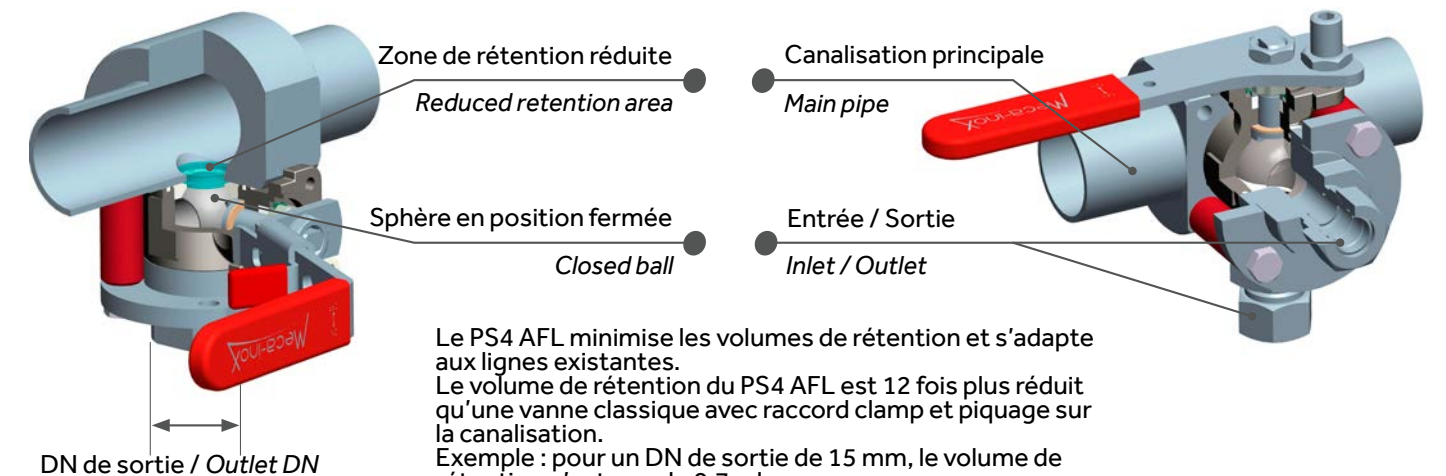
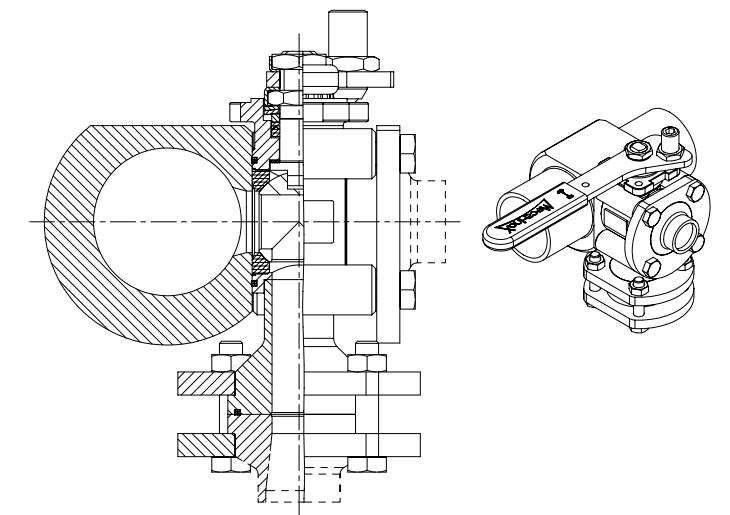

Le PS4 AFL minimise les volumes de rétention et s'adapte aux lignes existantes. Le volume de rétention du PS4 AFL est 12 fois plus réduit qu'une vanne classique avec raccord clamp et piquage sur la canalisation. Exemple : pour un DN de sortie de 15 mm, le volume de rétention n'est que de 0,7 ml.

PS4 AFL minimizes the volume retention while enabling adaptation to existing lines. The volume retention of a PS4 AFL is 12 times smaller than a standard valve with clamp fitting and T piping. Example: The DN 15 volume retention is only 0,7ml.

En standard :
Sphère affleurante
Version " True bore " raclable

Sur demande :
Dimensions et raccords suivant besoins clients
Sièges ½ coquilles

On standard:
Flush ball
"True bore" piggable version

On request:
Dimensions & type of connections according to customer needs
Cavity fillers

VANNE PRISE ÉCHANTILLON
SAMPLING BALL VALVE

Dimensions et raccords

suivant besoins clients

En standard :
Levier cadenassable
Anti-goutte
Choix du volume à prélever
Choix du flacon
Ligne principale étanche durant la manœuvre

Sur demande :
Porte échantillon
Clapet d'isolement
Autres matériaux
1/2 Coquilles
Version ATEX

Dimensions & type of connection

according to customer needs

On standard:
Lockable handle
Anti-drip
Choice of the sampled volume
Choice of bottle
Main line sealed during operation

On request:
Sample holder
Isolating check valve
Other materials
Cavity fillers
ATEX version

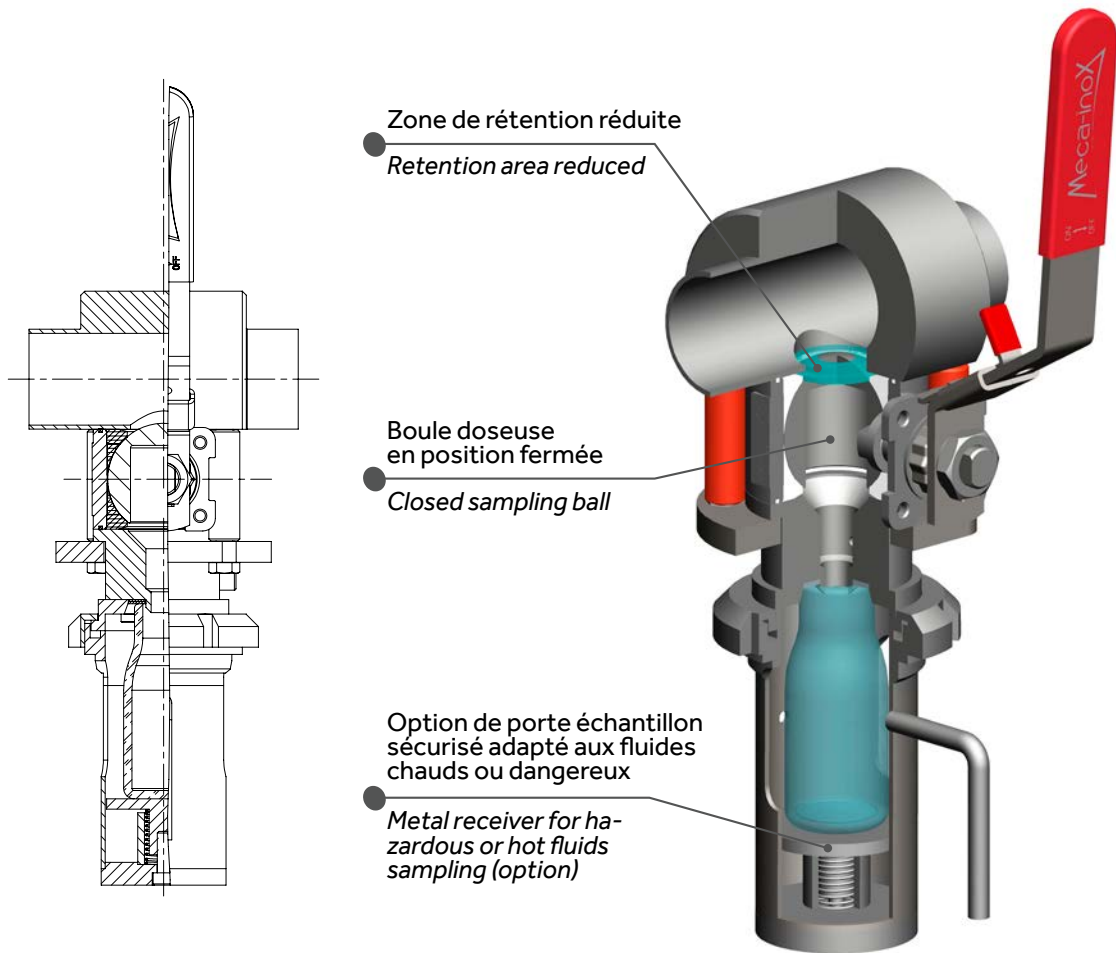

Le robinet PS4 PE (adaptation de la vanne PS4 AFL) a une zone "morte" 10 fois plus réduite qu'une vanne classique avec raccord clamp et piquage. Exemple : pour un DN sortie = 25 mm, le volume de rétention (vanne fermée) n'est que de 2 ml. Le prélèvement est sécurisé par l'absence de communication entre la canalisation principale et la sortie de l'échantillon. La boule doseuse garantit un volume prélevé constant, différents volumes sont disponibles : 15, 30, 50 et 100 cc.

The volume retention of a PS4 PE valve is 10 times smaller than a standard valve with clamp fitting and T piping. Example: the DN 25 volume retention is only 2ml. Constant tightness between pressurised pipe and sampling outlet ensures fully safe operation. Several sampling ball volume are available: 15, 30, 50 & 100cc.

VANNE ISOLEMENT & PURGE
DOUBLE BLOCK AND BLEED

DN 15 à 50 | Size 1/2" to 2"

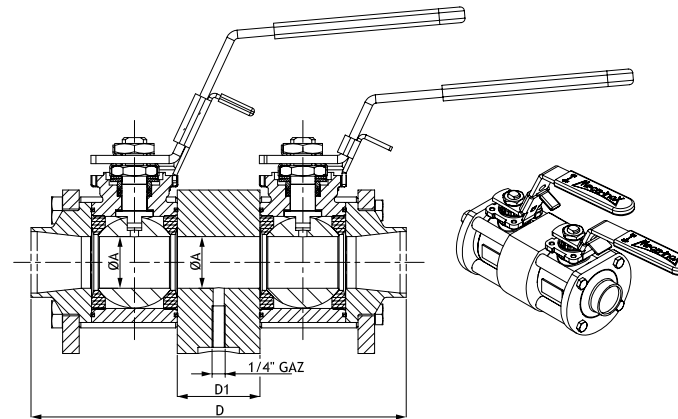

Dimensions et raccords
suivant besoins clients

Sur demande :
Autres matériaux
1/2 Coquilles
Version ATEX
Robinet de purge
Version motorisée (mixte possible)

Sécurisation de l'isolement de lignes lors des opérations de maintenance

DN 65 à 100 | Size 2" 1/2 to 4"

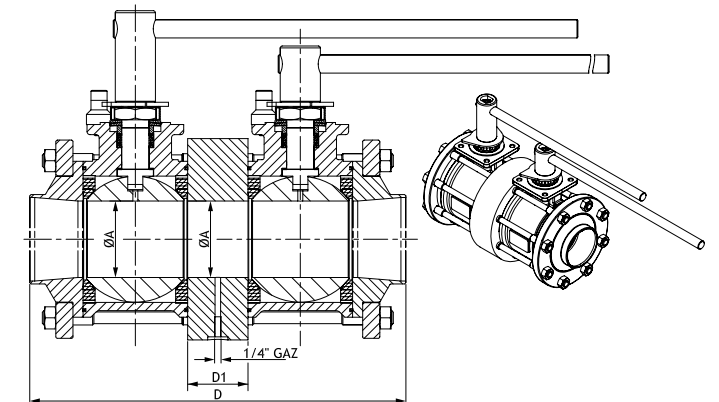

Dimensions & type of connection
according to customer needs

On request:
Other materials
Cavity fillers
ATEX version
Bleed valve
Actuated version (mixed possible)

Provides safe isolation of lines during maintenance

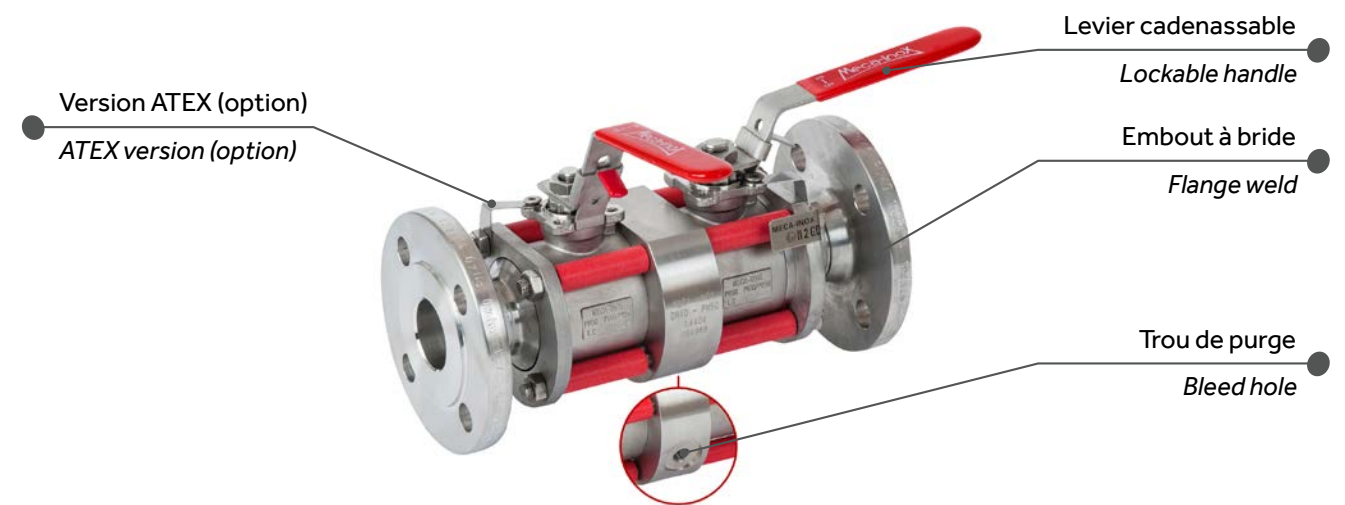

DN Size	ØA	D	D1
15	1/2"	14	124.4
20	3/4"	19	151.6
25	1"	25	181.4
32	1"1/4	32	198.2
40	1"1/2	38	213.8
50	2"	50	281

DN Size	ØA	D	D1
65	2"1/2	64	324
80	3"	76	374
100	4"	100	415

VANNE ENVELOPPE THERMIQUE
STEAM JACKETED BALL VALVE

DN 08 à 50 | Size 1/4" to 2"

DN 65 à 150 | Size 2 1/2" to 6"

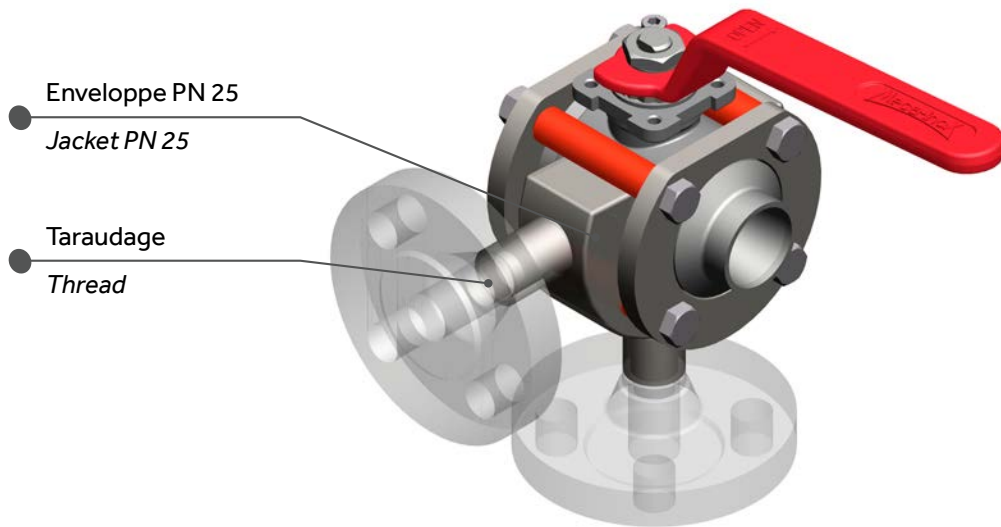
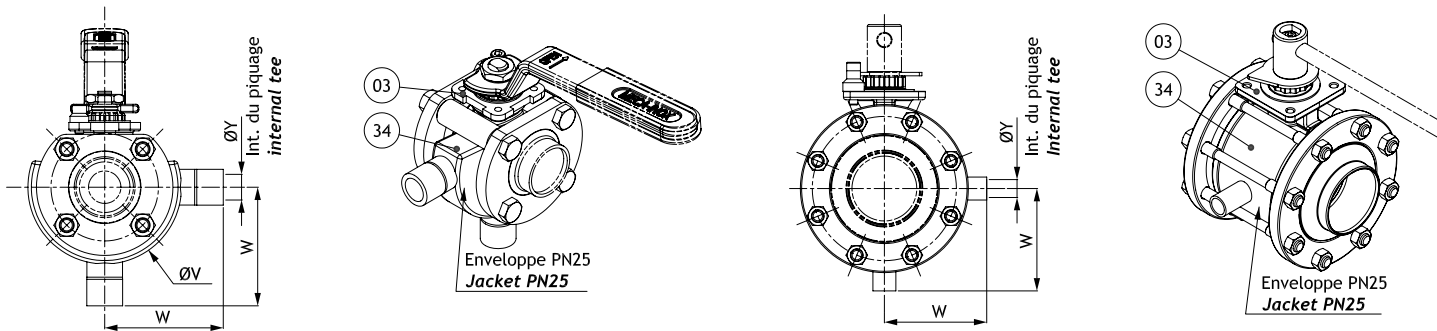

N°	Nb	Description	Matière (EN)
03	1	Corps	1.4409
34	1	Double enveloppe thermique	1.4404

Item	Qty	Description	Material (ASTM)
03	1	Body	CF-3M
34	1	Steam jacket	316L

DN Size	PN	ØV	W	ØY	Volume enveloppe thermique Volume steam jacket
08-12	100	70	67	3/8"	9 cm ³
15	100	70	72	3/8"	23 cm ³
20	100	90	75	3/8"	48 cm ³
25	70	90	74	3/8"	76 cm ³
32	70	97	79	3/8"	102 cm ³
40	50	107	89	3/8"	184 cm ³
50	50	127	106	1/2"	289 cm ³
65	40	-	100	1/2"	110 cm ³
80	40	-	120	1/2"	114 cm ³
100	25	-	130	1/2"	211 cm ³
125	25	-	150	3/4"	407 cm ³
150	16	-	170	3/4"	527 cm ³

CLAPET
CHECK VALVE

DN 08 à 50

Size 1/4" to 2"

PN 80

Un montage vertical est préconisé sur un écoulement ascendant.
Marquage directionnel sur le corps.
Dans le cas d'un montage horizontal, la différence de pression minimum aval/amont pour assurer l'étanchéité est de 1 bar.

Sur demande :

Version ATEX II2GD
Version dégraissée pour application oxygène
Version cryogénique
Version 304L / 904L (UB6) / Alloy 22
Marquage π suivant la directive 2010/35/UE
TPED : certification ADR § 1.8.7.6

PN 80

Vertical mounting is advised on an upward flow.
Arrow marked on the body.
In case of a horizontal mounting, the pressure difference between downstream and upstream to ensure sealing should be at least 1 bar.

On request:

ATEX II2GD
Degreased version for oxygen application
Cryogenics applications
Alloy 22 / 304L / 904L version
π marking according to 2010/35/UE TPED: certification ADR §1.8.7.6

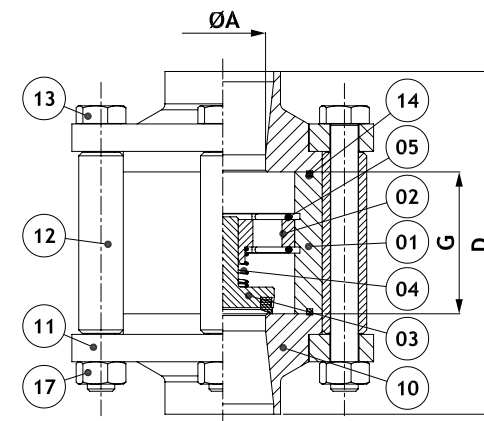
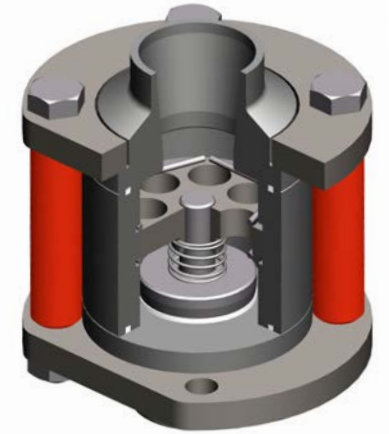

Pression de décollement 0.4 à 0.6 bar Opening pressure 6 to 9 psi

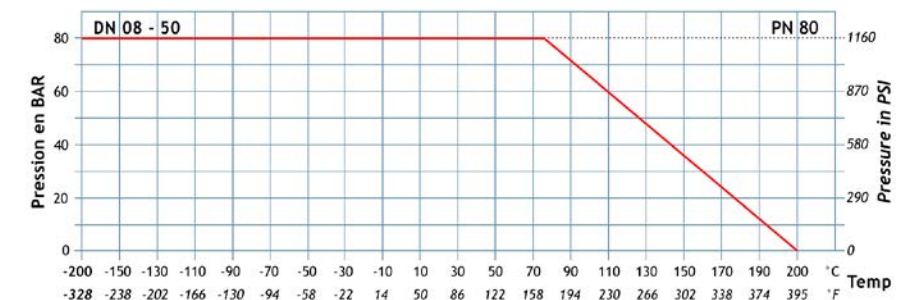

N°	Nb	Description	Matière (EN)
01	1	Corps	1.4404
02	1	Guide de clapet	1.4404
03	1	Disque	1.4404 + PTFE
04	1	Ressort de clapet	1.4401
05	2	Jonc CERCLAM	1.4401
10	2	Emboutis libres	1.4404
11	2	Brides tournantes	1.4307
12	4	Entretoises	PTFE
13	4	Vis TH	1.4301
14	2	Joints de corps	PTFE
17	4	Écrous de serrage	1.4301

Item	Qty	Description	Material (ASTM)
01	1	Body	316L
02	1	Plate guide	316L
03	1	Disc	316L + PTFE
04	1	Spring	316
05	2	Circlip CERCLAM	316
10	2	Loose end	316L
11	2	Body flange	304L
12	4	Distance piece	PTFE
13	4	Screw TH	304
14	2	Body seal	PTFE
17	4	Nut screw	304

Nominal	DN / Size				PN	Ø A	D	G
	N	V	Standard	Reduced				
08-12	1/4"-3/8"	15	1/2"	80	11	65	20.4	
15	1/2"	20	3/4"	80	14.2	70	24.4	
20	3/4"	25	1"	80	21	85	31.6	
25	1"	32	1 1/4"	80	25	100	41.4	
32	1 1/4"	40	1 1/2"	80	32	110	48.2	
40	1 1/2"	50	2"	80	38	125	56.2	
50	2"	65	2 1/2"	80	50	150	71.0	

WISEUR
SIGHT GLASS

DN 08 à 50

Cartouche précontrainte
Protection du tube en verre
(pare-éclats en acier inoxydable)
Anti-gouttes évitant les projections sur la paroi
Autre matériaux sur demande

Size 1/4" to 2"

Pre-stressed cartridge
Efficient glass protection
(glass protector in stainless steel)
Drip avoiding the projection of drops on the walls
Others materials on request

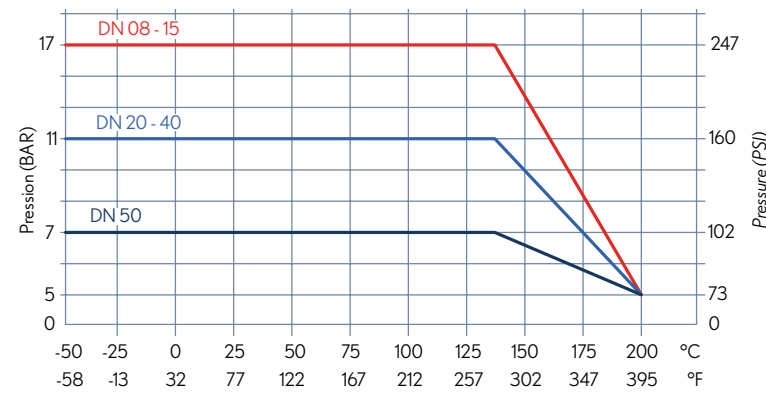
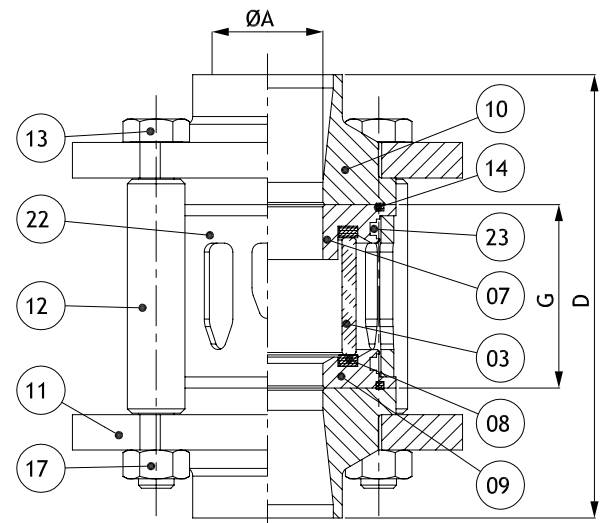
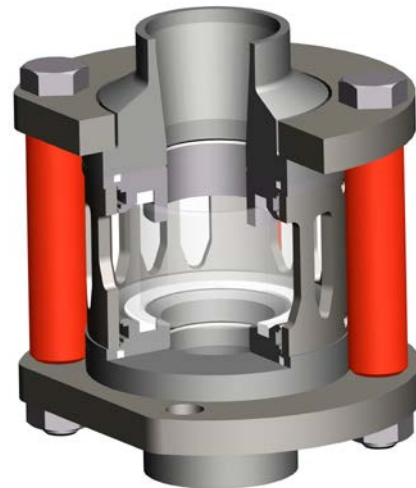

Nominal	DN / Size			PN	Ø A	D	G	PS bars
	N	Full	V					
08-12	1/4"-3/8"	15	1/2"	17	10.5	65	20.4	17
15	1/2"	20	3/4"	17	14	70	24.4	17
20	3/4"	25	1"	11	19	85	31.6	11
25	1"	32	1"1/4	11	25	100	41.4	11
32	1"1/4	40	1"1/2	12	32	110	48.2	12
40	1"1/2	50	2"	11	38	125	56.2	11
50	2"	65	2"1/2	7.5	50	150	71.0	7.5

N°	Nb	Description	Matière (EN)
03	1	Verre	PYREX
07	1	Flasque supérieur	1.4404
08	2	Joint de verre	PTFE Microcellulaire
09	1	Flasque inférieur	1.4404
10	2	Embouts libres	1.4404
11	2	Brides tournantes	1.4307
12	4	Entretoises	PTFE
13	4	Vis TH	1.4301
14	2	Joints de corps	PTFE
17	4	Écrous de serrage	1.4301
22	1	Pare éclats	1.4404
23	8	Vis HC	1.4301

Item	Qty	Description	Material (ASTM)
03	1	Glass	PYREX
07	1	Seal holder	316L
08	2	Glassseal	Microcellular PTFE
09	1	Upper seal holder	316L
10	2	Loose end	316L
11	2	Body flange	304L
12	4	Distance piece	PTFE
13	4	Screw TH	304
14	2	Body seal	PTFE
17	4	Nut screw	304
22	1	Protector	316L
23	8	Screw HC	304

FILTRE
FILTER

DN 08 à 50

Seuil de filtration
0.45 mm pour DN 10 à 20
0.8 mm pour DN 25 à 50
Autres seuils de filtration sur demande.

Size 1/4" to 2"

Filtering grade
0.45mm for size 1/4" to 3/4"
0.8mm for size 1" to 2"
Other filtering grade on request.

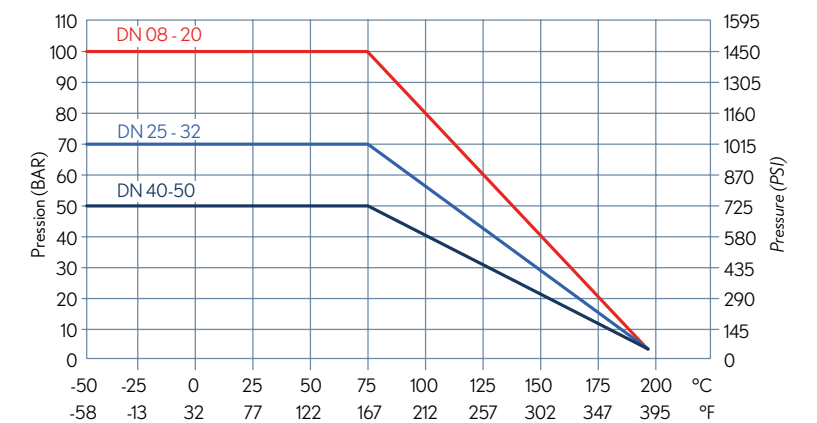
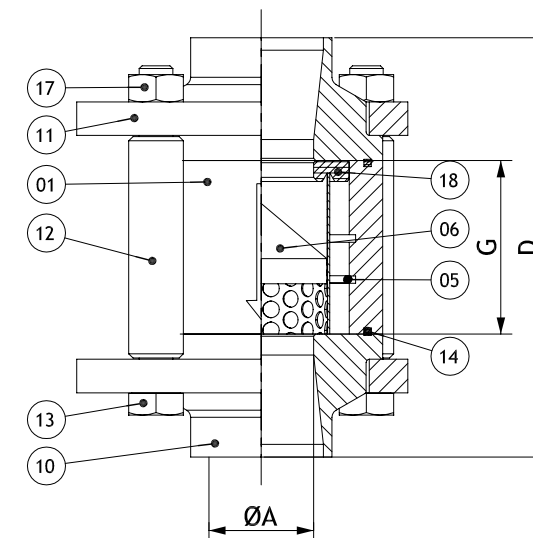
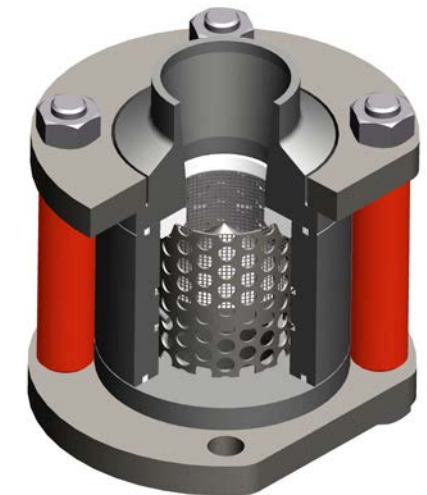

Nominal	DN			PN	Ø A	D	G
	N	Full	V				
08-12	1/4"-3/8"	15	1/2"	100	11.1	65	20.4
15	1/2"	20	3/4"	100	14	70	24.4
20	3/4"	25	1"	100	19	85	31.6
25	1"	32	1"1/4	70	25	100	41.4
32	1"1/4	40	1"1/2	70	32	110	48.2
40	1"1/2	50	2"	50	38	125	56.2
50	2"	65	2"1/2	50	50	150	71.0

N°	Nb	Description	Matière (EN) Inox
01	1	Corps	1.4404
05	1	Jonc CERCLAM	1.4401
06	1	Cartouche filtrante DN10 à 20 : 0.45 mm DN25 à 50 : 0.80 mm	1.4404
10	2	Embouts libres	1.4404
11	2	Brides tournantes	1.4307
12	4	Entretoises	PTFE
13	4	Vis TH	1.4301
14	2	Joints de corps	PTFE
17	4	Écrous de serrage	1.4301
18	1	Joint de cartouche	PTFE

Item	Qty	Description	Material (ASTM) S.steel
01	1	Body	316L
05	1	Circlip CERCLAM	316L
06	1	Filter element DN10 à 20 : 0.45 mm DN25 à 50 : 0.80 mm	316L
10	2	Loose end	316L
11	2	Body flange	304L
12	4	Distance piece	PTFE
13	4	Screw TH	304
14	2	Body seal	PTFE
17	4	Nut screw	304
18	1	Filter seal	PTFE

VANNE ÉCONOMIQUE
ECONOMIC VALVE

DN 08 à 80

Taraudé gaz & à souder en bout
Passage intégral
Liaison antistatique

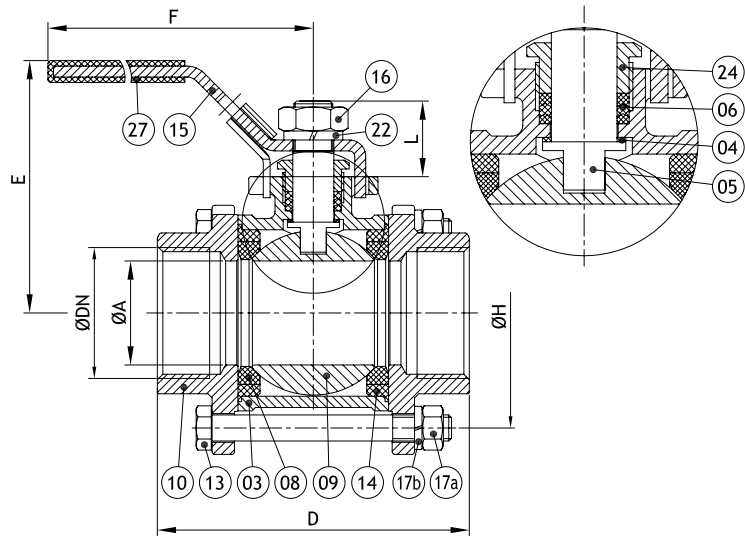

Size 1/4" to 3"

BSP thread & Butt welding
Full bore
Antistatic device

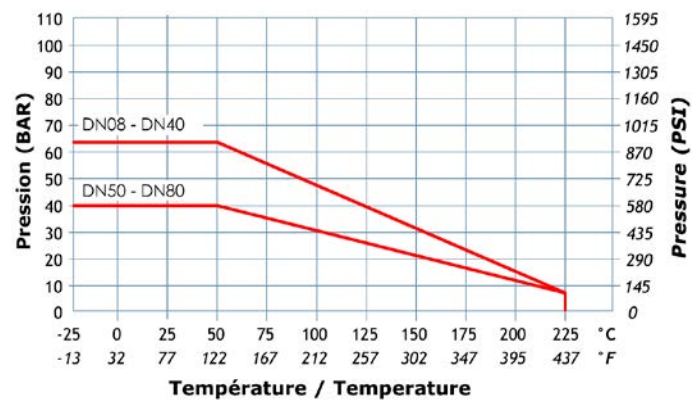

N°	Nb	Description	Matière (EN) Inox
03	1	Corps monobloc ISO	1.4408
04	1	Rondelle de friction	PTFE + 25% Carbone
05	1	Tige de manœuvre	1.4401
06	1	Garniture	PTFE + 25% Carbone
08	2	Sièges	PTFE + 25% Carbone
09	1	Tournant sphérique	1.4408
10	2	Embout de raccordement	1.4408
13	4	Vis TH DN08 à DN65	1.4301
	6	Vis TH DN80 à DN100	1.4301
14	2	Joints de corps	PTFE + 25% Carbone
15	1	Levier	1.4301
16	1	Ecrou de levier	1.4301
17a	4	Écrous de serrage DN08 à DN65	1.4301
	6	Écrous de serrage DN80 à DN100	1.4301
17b	4	Rondelle Grower DN08 à DN65	1.4301
	6	Rondelle Grower DN80 à DN100	1.4301
22	1	Rondelle Grower	1.4301
24	1	Presse etoupe	1.4301
27	1	Manchon de levier	Plastic

Item	Qty	Description	Material (ASTM) S.steel
03	1	Body	CF8M
04	1	Stem thrust seal	PTFE + 25% Carbon
05	1	Stem	316
06	3	Stem packing	PTFE + 25% Carbon
08	2	Seat	PTFE + 25% Carbon
09	1	Ball	CF8M
10	2	Cap	CF8M
13	4	Bolt DN 1/4" to 2"1/2	304
	6	Bolt DN 3" to 4"	304
14	2	Gasket	PTFE + 25% Carbon
15	1	Handle	304
16	1	Stem nut	304
17a	4	Nut screw DN 1/4" to 2"1/2	304
	6	Nut screw DN 3" to 4"	304
17b	4	Bolt washer DN 1/4" to 2"1/2	304
	6	Bolt washer DN 3" to 4"	304
22	1	Spring Washer	304
24	1	Gland	304
27	1	Plastic Cover	Plastic

DN Size	ØA	D	E	F	ØH	L	M	ISO 5211	Poids (Kg) Weight (Kg)
8	1/4"	11.6	58	56	102	15	5	F03	0.400
12	3/8"	12.7	58	56	102	15	5	F03	0.400
15	1/2"	15	63	65	123	16	6.5	F03	0.550
20	3/4"	20	73	67	123	16	6.5	F03	0.700
25	1"	25	85	79	153	21	8	F04	1.050
32	1"1/4	32	96	84	153	21	8	F04	1.600
40	1"1/2	38	114	92	183	25	9.5	F05	2.250
50	2"	50	134	99	183	29	9.5	F05	3.400
65	2"1/2	65	180	136	246	40	12	F07	-
80	3"	80	200	146	246	48	12	F07	-

VANNE MONOBLOC
1-PIECE BALL VALVE

Size 1/4" to 2"

BSP thread
Full bore - PN 63
ATEX with antistatic device
Silicone free
Packaged in individual plastic bag

DN 08 à 50

Taraudé gaz
Passage intégral - PN 63
ATEX avec liaison antistatique
Sans trace de silicone
Emballé dans un sachet plastique individuel

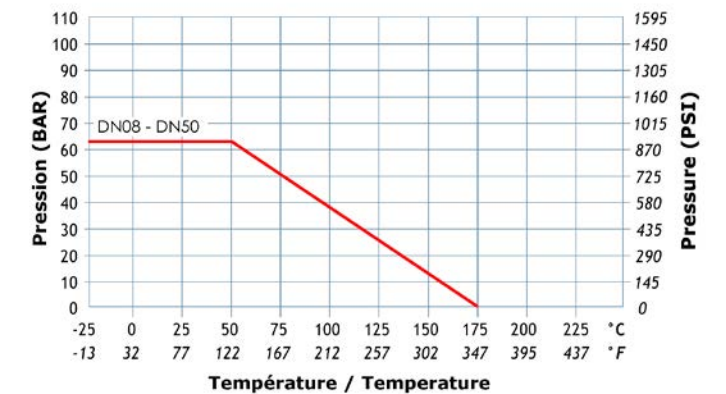
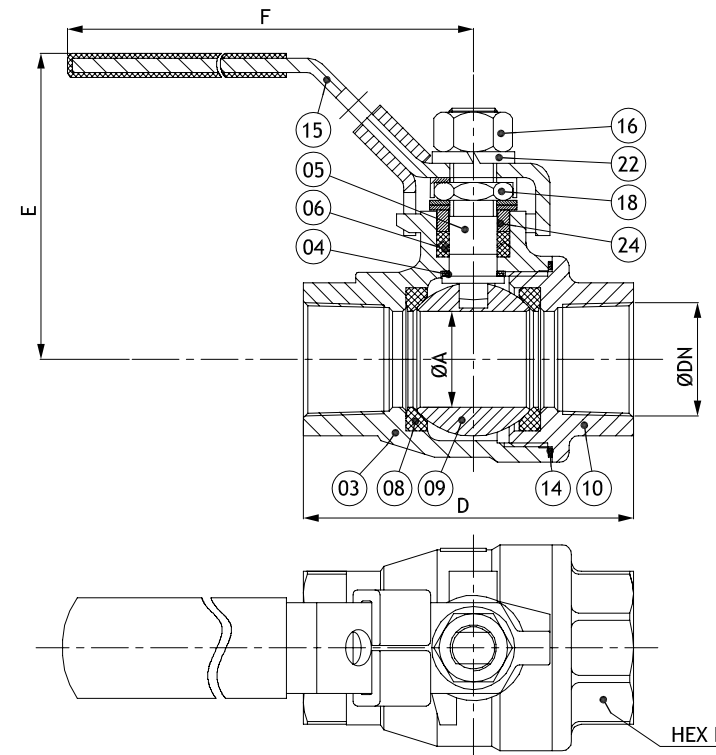

N°	Nb	Description	Matière (EN) Inox
03	1	Corps monobloc ISO	1.4408
04	1	Rondelle de friction	PTFE
05	1	Tige de manœuvre	1.4401
06	1	Garniture Chevron	PTFE
08	2	Sièges	PTFE
09	1	Boisseau	1.4408
10	1	Embout de raccordement	1.4408
14	1	Joints de corps	PTFE
15	1	Levier	1.4301
16	1	Ecrou de levier	1.4305
22	1	Rondelle Grower	1.4301
18	1	Ecrou de Presse étoupe	1.4305
24	1	Fouloir	1.4301

Item	Qty	Description	Material (ASTM) S.steel
03	1	Body	A351 CF 8 M
04	1	Stem thrust seal	PTFE
05	1	Stem	A276 316
06	3	V Stem packing	PTFE
08	2	Seat	PTFE
09	1	Ball	A351 CF 8 M
10	1	Body connector	A351 CF 8 M
14	1	Body seal	PTFE
15	1	Handle	304
18	1	Lever nut	A194-8
22	1	Stem washer	304
18	1	Gland nut	A194-8
24	1	Gland	304

DN Size	ØA	D	E	F	HEX B	Poids (Kg) Weight (Kg)
8	1/4"	10.6	58	59	100	0.235
12	3/8"	12	58	59	100	0.305
15	1/2"	15	75	59	100	0.385
20	3/4"	20	80	65.5	129	0.490
25	1"	25	90	78.8	156	0.835
32	1"1/4	32	110	85.5	156	1.240
40	1"1/2	38	120	98	182	1.885
50	2"	50	140	106.5	182	2.865

Version pneumatique

Simple ou double effet
Type " C "
Type " E "
Type " CNi "

Pneumatic version

Spring return or double acting
C-Type
E-Type
CNi-Type

Version électrique

Double effet
Type " EZ "

Electric version

Double acting
EZ-Type



Motorisation pneumatique Type " S "
"S" Type pneumatic actuation



Motorisation pneumatique Type " C "
"C" Type pneumatic actuation



Motorisation électrique Type " EZ4 - EZ15 "
"EZ4-EZ15" Type electric actuation



Motorisation électrique Type " EZ25 - EZ60 "
"EZ25-EZ60" Type electric actuation

ACT | ACC

**MOTORISATION PNEUMATIQUE
PNEUMATIC ACTUATION**

Présentation

Lors de ses recherches, l'objectif de Trutorq a été de conférer à son actionneur un des meilleurs rendements du marché afin de :

- minimiser les consommations d'air moteur,
- assurer un dimensionnement justement proportionné de l'actionneur sur le robinet.

Pour que ce soit SIMPLE, FIABLE et REACTIF, Meca-Inox a mis en place des moyens optimums pour réaliser une large variété de configurations de motorisation.

SIMPLE : Meca-inox assure la livraison d'ensembles motorisés sécurisés et garantis suivant les données techniques de vos spécifications.

FIABLE : les composants utilisés ont été spécialement conçus pour être soumis aux contraintes inhérentes à la motorisation. Les essais unitaires accompagnent chaque assemblage.

REACTIF : la spécialisation et la coordination de nos équipes techniques et commerciales, permettent une réactivité maximum dans le traitement de vos demandes dans ce domaine.

TYPE - C

Une version qui comprend l'essentiel. Ce système pignon / crémaillère se distingue par des innovations en matière de guidage, d'entraînement, et d'étanchéité qui assurent la fiabilité et la longévité requises dans les environnements industriels.



TYPE - E

En plus des caractéristiques du type C, le type E comprend une platine amovible permettant la motorisation directe sans autre élément de liaison. La platine est pourvue de doubles butées offrant une possibilité de réglage précis en ouverture ou fermeture en toute sécurité sans être en contact avec les parties mobiles.



TYPE - CNI

Applicable aux deux versions précédentes, le CNI, procédé unique, est un revêtement de nickel imprégné qui permet une utilisation dans les conditions de corrosion les plus agressives. Ce revêtement améliore la fiabilité de l'actionneur, par l'augmentation de la dureté ainsi que l'optimisation des frottements entre les joints de pistons et le corps.



**MOTORISATION PNEUMATIQUE
PNEUMATIC ACTUATION**

Introduction

During the design phase, TRUTORQ's purpose was to create an actuator range with the best performance in the market in order to:

- minimize air consumption,
- guarantee the appropriate sizing of the actuator for each size of ball valve.

To make it SIMPLE, RELIABLE and FLEXIBLE, MECA-INOX has implemented optimal resources to offer a wide range of actuator configuration.

SIMPLE: MECA-INOX delivers complete assemblies of motorized ball valves with a full manufacturer guarantee according customers specifications.

RELIABLE: Components have been designed to support stresses usually met in case of motorization.

FLEXIBLE: The technical experience of our teams ensures a quick reactivity to fulfill your enquiries and specifications.

C-TYPE

This version includes main features. This "Rack and Pignon System" has unique benefits in term of guiding, driving, and sealing with ensure the reliability and the lifetime required in industrial processes.



E-TYPE

In addition of the C-TYPE features, the E-TYPE includes a removable Body Adaptor Kit (B.A.K.) for a direct mounting of the actuator on the valve. This adaptor offers two stops for a better set up of the rotation in both Open and Close positions. This set up is done in secured conditions as the operator does not interfere on parts in movement.



CNI-TYPE

Available in both above versions, CNI®, unique surface treatment, is a nickel impregnation coating. This coating improves the reliability of the actuator, due to a higher hardness and the optimisation of the contact between pistons seals and the body.



**MOTORISATION PNEUMATIQUE
PNEUMATIC ACTUATION**

Avantages

- **INDICATEUR TRUVISION (option)**
Indicateur visuel de position. Utilisable également comme came pour détecteurs de proximité.
- **GUIDES DE PISTON**
Système unique de guides qui absorbent les efforts latéraux exercés sur l'axe (dûs aux ressorts). Maintient les pistons en alignement optimal pour faciliter le mouvement.
- **JOINT ARRIERE**
Augmente la durée de vie du joint de piston. Réduit la friction entre les pistons et le corps de l'actionneur.
- **AXE ET CAMES**
L'axe et les cames de réglage sont usinés dans la barre.
Les cames permettent un ajustement de 2,5 ° dans chaque sens de rotation. La profondeur de l'axe permet l'utilisation de tout type d'entraîneur ou tige de manœuvre pour flasquage direct.
- **BOITIER D'ADAPTATION ET DE CAMES (B.A.K.), en option**
Incorporé dans le corps de l'actionneur, le B.A.K. est usiné et taraudé suivant norme ISO / DIN ou platine spécifique de robinetterie pour le flasquage direct.
Le B.A.K. est aussi équipé d'un système de cames de réglage et vis de verrouillage.

- **TRIPLE GUIDAGE DE L'AXE**
Elimine les contacts métal-métal. Absorbe l'effort latéral dû à l'arrêt en rotation exercé par le système de came.
- **PATINS DE GUIDAGE**
Le double patin encastré absorbe les efforts de déplacement latéral. Ces patins évitent le contact métal-métal et améliorent le glissement.
- **RESSORTS**
Conception unique brevetée. Les ressorts sont situés dans les alésages des pistons. Les versions simple effet "TSR" utilisent les mêmes capots que les versions double effet "TDA".
Les ressorts sont fabriqués en SiCr. avec certificat 3.1 b sur demande. La longueur de la boulonnerie est calculée afin d'assurer la détente complète des ressorts évitant l'éjection des capots.
- **INSERT D'ACCOUPEMENT**
Usiné dans la barre, il peut être utilisé avec des carrés dans l'axe de la tuyauterie ou décalés à 45 °.
Des versions correspondant à la plupart des sorties d'axe sont disponibles.
L'insert est maintenu dans son logement par une clavette.

**MOTORISATION PNEUMATIQUE
PNEUMATIC ACTUATION**

Features & benefits

- **TRUVISION INDICATOR (optional)**
Local visual indicator and positioners or as a puck for proximity sensors (optional extra).
- **TWIN GUIDE BARS**
Unique twin guide bars absorb adverse side loading from rack at the start of each stroke and maintains even engagement between rack & pinion for smooth operation.
- **BACK UP BEARING**
Increases life span of the piston "O" seal and improves and reduces friction travel.
- **DRIVESHAFT & CAM**
The shaft and adjustment cam are machined from solid bar material. The cam mechanism allows for 2.5° overtravel in both directions. The inner depth of the driveshaft allow for total engagement of any valve shaft height for direct mount.
- **BODY ADAPTOR KIT & STOP ADJUSTMENTS on request**
Recessed into the actuator's main body, the "B.A.K" is drilled in accordance to DIN/ISO standards or valve topworks, for direct mounting options. The "B.A.K" is also fitted with our unique open & closed stop end adjustment and locking screws.

- **TRIPLE SHAFT BEARINGS**
Eliminates metal to metal contact and absorbs the impact load on the stop cam drive mechanism.
- **PISTON WEAR PADS**
The dual encapsulated wear pads absorb the adverse side loading at start of each stroke. The 4 off encapsulated wear pads also ensure no metal to metal contact thus providing low friction travel.
- **SPRINGS**
Unique patented spring design, located inside piston rack.
"TSR" units utilise the same end caps as "TDA". Springs are manufactured from SiCr in compliance to EN 10204 and available with 3.1 certificate on request.
Long bolting is a standard feature in order to fully relax springs.
- **INSERT SLEEVE**
Manufactured from stainless steel bar, it can be rotated for cross & parallel mounting and suit most valve shafts.
The insert is held inside the driveshaft by means of a circlip.

**MOTORISATION PNEUMATIQUE
PNEUMATIC ACTUATION**

Actionneur CNI

Le revêtement " CNI " des actionneurs Trutorq est un procédé unique de Nickel imprégné. Différente des actionneurs revêtus en nickelage classique " ENP ", l'imprégnation de nickel chimique assurent un revêtement qui :

- ne se détache pas,
- ne se fissure pas,
- ne s'écaille pas.

Particularités de l'actionneur CNI

- Toutes les surfaces étant trempées dans une solution, l'épaisseur du dépôt est uniforme et vérifiée au micron près.

Définition du bain de nickel

La solution du bain est composée d'un alliage dense de nickel et de phosphate.

Définition du procédé autocatalytique

Lors du procédé de dépôt, une couche de nickel se forme sur la surface primaire, cette couche et les suivantes deviennent catalyseur assurant l'uniformité de l'épaisseur.

Critères de développement du CNI

1. Résistance à la corrosion
2. Réduction des frictions
3. Dureté
4. Pouvoir lubrifiant
5. Dépôt uniforme malgré les géométries
6. Alliage nickel non magnétique
7. Aucune émission d'étincelle
8. L'état de surface est d'environ Ra 0.4 µm

Revêtement " CNI "

Coating Nickel Impregnated.

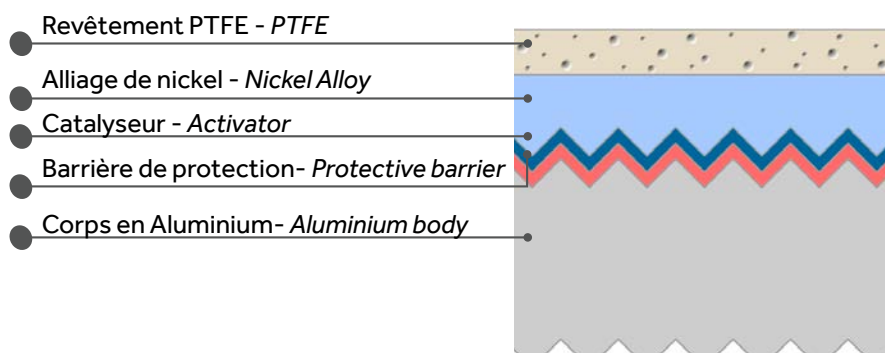

CNI Actuator

CNI coating used on Trutorq actuators is a unique process of Nickel Impregnation. In opposition of usual nickeling "ENP", impregnation of chemical Nickel ensures to the coating:

- no risk to detach
- no risk to fissure
- no risk to flack off

Features of CNI actuators

- All surfaces have been wetted in a appropriate bath providing a uniform thickness, controlled to Ra 1µm precision.

Definition of the nickel bath

The liquid is based of nickel alloy and phosphate.

Definition of the catalysis process

During the coating process, a nickel coat is formed on the surface. This coat and the others become catalyst to ensure the regular thickness.

Reasons to develop the CNI design

1. Corrosion resistance
2. Decreasing of frictions
3. Hardness
4. Lubrication property
5. Regular coating although multiple surfaces
6. The Nickel is non-magnetic
7. No spark source
8. Surface roughness is about Ra 0.4µm

**MOTORISATION PNEUMATIQUE
PNEUMATIC ACTUATION**

Caractéristiques de fonctionnement

TDA = Double effet
 Orifice " A " = Entrée d'air pour ouverture (sens anti-horaire)
 Orifice " B " = Entrée d'air pour fermeture (sens horaire)
 TSR = Simple effet
 Orifice " A " = Entrée d'air pour ouverture (sens anti-horaire et compression des ressorts)
 Orifice " B " = Fermeture par ressorts
 Pression d'alimentation maximum = 10 bars
 Fonctionnement Ouverture par manque d'air :
 Sortir les pistons du corps de l'actionneur
 Tourner les pistons 180 ° autour de leur axe
 Remonter les pistons dans le corps de l'actionneur.
 Fluide moteur :
 Air (sec ou lubrifié), gaz non corrosifs, huile hydraulique.
 Température :
 O-ring Buna+Nitrile : -40 °C à 100 °C (en standard)

Basic operating details

*TDA = Double acting
 Port "A"= Air to open (Anti-clockwise)
 Port "B" = Air to Close (Clockwise)
 TSR = Simple acting (Spring Return)
 Port "A" = Air to open (Anti-clockwise compressing springs)
 Port "B" =Springs to close (Clockwise)
 Maximum air pressure = 10 bars
 Fail Safe Open:
 Remove pistons and rotate them 180° about their axis
 Reinstall pistons according reverse procedure
 Drive medium:
 Air (dry or lubricated), non-corrosive gas, light hydraulic oil
 Temperature:
 Buna+Nitrile O-ring: -40°C à 100°C*

Temps de manœuvre maximum en seconde (5.5 bars/ 80 psi) *Maximum operating time per second (5.5 bars / 80 psi)*

Type Actionneur Actuator	3	5	8	12	20	35	55	70	100	150
Double Effet ouvert DA open	<1	<1	<1	1.5	2	2.5	3.5	4	4.5	5
Double Effet fermé DA close	<1	<1	<1	1.5	2	2.5	3.5	4	4.5	5
Simple Effet ouvert SR open	<1	<1	<1	1.5	2	2.5	3.5	4	5.5	7
Simple Effet fermé SR close	<1	<1	<1	1	1.5	2	3	3	3	4

Consommation d'air (en litres) *Air consumption per stroke (liters)*

Type Actionneur Actuator	3	5	8	12	20	35	55	70	100	150
Orifice " A " pour ouvrir Port "A" to open	0.09	0.18	0.34	0.49	0.90	1.69	2.80	3.05	5.52	7.60
Orifice " B " pour fermer Port "B" to close	0.12	0.24	0.41	0.64	1.00	1.90	3.40	3.70	5.90	9.60

Poids de l'actionneur (en Kg) *Overall actuator weight (Kg)*

Type Actionneur Actuator	3	5	8	12	20	35	55	70	100	150
Double Effet - DA	1.0	1.8	3.1	4.5	6.9	11.5	20.0	22.4	31.2	44.4
Simple Effet - SR	1.1	1.9	3.4	5.2	7.7	13.2	22.7	26.5	35.8	52.8

**MOTORISATION PNEUMATIQUE
PNEUMATIC ACTUATION**

Normes & certifications

Normes de raccordement des actionneurs
- Platine et carré d'entraînement suivant les normes ISO 5211 , DIN 3337
- Montage des interfaces de pilotage et de contrôle suivant les spécifications techniques Namur VDI/ VDE 3845

Directive Européenne
Les actionneurs Trutorq répondent aux exigences essentielles de sécurité et de santé des travailleurs selon les Directives de la Communauté Européenne :
- Directive 94/9/CE dite Atex : Marquage des équipements pour une utilisation en surface de catégorie de risque de niveau 2 en atmosphère gazeuse ou poussière :
- Directive 97 /23/CE DESP
- Directive 89 /392/CE annexe IIB et ses amendements



Couples de manœuvre double effet Double acting operating torques

Actionneur Actuator	Pression d'alimentation - Air supply					
	3 bars	4 bars	5 bars	5.5 bars	6 bars	7 bars
TDA 3	11.8 Nm	15.8 Nm	19.7 Nm	21.7 Nm	23.7 Nm	27.6 Nm
TDA 5	25.4 Nm	33.8 Nm	42.3 Nm	46.5 Nm	50.7 Nm	59.2 Nm
TDA 8	45.0 Nm	60.0 Nm	75.0 Nm	82.5 Nm	90.0 Nm	105.0 Nm
TDA 12	61.3 Nm	81.7 Nm	102.1 Nm	112.3 Nm	122.5 Nm	142.9 Nm
TDA 20	101.0 Nm	134.6 Nm	168.3 Nm	185.1 Nm	201.9 Nm	235.6 Nm
TDA 35	187.0 Nm	249.4 Nm	311.7 Nm	342.9 Nm	374.1 Nm	436.4 Nm
TDA 55	292.3 Nm	389.7 Nm	487.1 Nm	535.8 Nm	584.5 Nm	681.9 Nm
TDA 70	412 Nm	550 Nm	687 Nm	756 Nm	824 Nm	962 Nm
TDA 100	561 Nm	748 Nm	935 Nm	1029 Nm	1122 Nm	1309 Nm
TDA 150	827 Nm	1103 Nm	1379 Nm	1517 Nm	1665 Nm	1931 Nm
TDA 250	1324 Nm	1765 Nm	2206 Nm	2427 Nm	2648 Nm	3089 Nm
TDA 400	2402 Nm	3202 Nm	4003 Nm	4403 Nm	4803 Nm	5604 Nm

Standard & approvals

Attachment standard of actuators:
- ISO flange and drive square according ISO5211;
DIN 3337
- Attachments for the solenoid valve and the limit switch box according Namur standard VDI/VDE 3845

European Directives:
Trutorq actuators are fulfill main requirements of safety and health for workers according European Directives:
- ATEX 94/9/CE: Marking for use in risk level 2 in gaseous or dust atmosphere.
- Directive 97 /23/CE PED
- Directive 89/392/CE and its addendum

Couples de manœuvre simple effet Spring return operating torques

Taille Actionneur MODELE Model	Nb Ressort Springs		Courbe ressort Spring stroke		Pression d'Alimentation (bar) - Air supply (bar)											
	Ext	Int	Début Start	Fin End	3 bars		4 bars		5 bars		5.5 bars		6 bars		7 bars	
TSR 3	1	1	2.6	1.3	10.5	9.2	14.4	13.2	18.4	17.1	20.4	19.1	22.3	21.1	26.3	25.0
	2	2	5.2	2.7	9.2	6.6	13.1	10.5	17.0	14.5	19.0	16.5	21.0	18.4	24.9	22.4
	3	3	7.9	4.0	7.8	4.0	11.8	7.9	15.7	11.9	17.7	13.8	19.7	15.8	23.6	19.8
	4	4	10.5	5.4	6.5	1.4	10.4	5.3	14.4	9.2	16.3	11.2	18.3	13.2	22.3	17.1
	5	5	13.1	6.7	5.1	-	9.1	2.7	13.0	6.6	15.0	8.6	17.0	10.6	20.9	14.5
TSR 5	6	6	15.7	8.0	3.8	-	7.7	0.1	11.7	4.0	13.7	6.0	15.6	8.0	19.6	11.9
	1	1	5.4	3.0	22.4	19.9	30.8	28.4	39.3	36.8	43.5	41.1	47.7	45.3	56.2	53.7
	2	2	10.9	6.0	19.4	14.5	27.8	22.9	36.3	31.4	40.5	35.6	44.7	39.8	53.2	48.3
	3	3	16.3	9.0	16.4	9.0	24.8	17.5	33.3	26.0	37.5	30.2	41.7	34.4	50.2	42.9
	4	4	21.8	12.0	13.4	3.6	21.8	12.1	30.3	20.5	34.5	24.7	38.7	29.0	47.2	37.4
	5	5	27.2	15.0	10.4	-	18.8	6.6	27.3	15.1	31.5	19.3	35.7	23.5	44.2	32.0
TSR 8	6	6	32.6	18.0	7.4	-	15.8	1.2	24.3	9.6	28.5	13.9	32.7	18.1	41.2	26.5
	4	0	38.4	21.1	23.9	6.6	28.9	21.6	53.9	36.6	61.4	44.1	68.9	51.6	83.9	66.6
	4	1	43.2	23.8	21.2	1.8	36.2	16.8	51.2	31.8	58.7	39.3	66.2	46.8	81.2	61.8
	4	2	48.0	26.4	-	-	33.6	12.0	48.6	27.0	56.1	34.5	63.6	42.0	78.6	57.0
TSR 12	4	3	52.8	29.0	-	-	21.0	7.2	46.0	22.2	53.5	29.7	61.0	37.2	76.0	52.2
	4	4	57.6	31.7	-	-	28.3	2.4	43.3	17.4	50.8	24.9	58.3	32.4	73.3	47.4
	4	0	52.4	28.8	32.5	8.9	52.9	29.3	73.3	49.7	83.5	59.9	93.7	70.1	114.1	90.5
	4	1	59.0	32.4	28.9	2.3	49.3	22.7	69.7	43.1	79.9	53.4	90.1	63.6	110.5	84.0
TSR 20	4	2	65.5	36.0	-	-	45.7	16.2	66.1	36.6	76.3	46.8	86.5	57.0	106.9	77.4
	4	3	72.1	39.6	-	-	42.1	9.6	62.5	30.0	72.7	40.3	82.9	50.5	103.3	70.9
	4	4	78.6	43.2	-	-	38.5	3.1	58.9	23.5	69.1	33.7	79.3	43.9	99.7	64.3
	4	0	86.8	47.7	53.2	14.2	86.9	47.8	120.6	81.5	137.4	98.3	154.2	115.1	187.9	148.8
TSR 35	4	1	97.7	53.7	47.3	3.3	80.9	37.0	114.6	70.6	131.4	87.5	148.2	104.3	181.9	137.9
	4	2	108.5	59.7	-	-	75.0	26.1	108.6	59.8	125.4	76.6	142.3	93.4	175.9	127.1
	4	3	119.4	65.6	-	-	69.0	15.3	102.6	48.9	119.5	65.8	136.3	82.6	170.0	116.2
	4	4	130.2	71.6	-	-	63.0	4.4	96.7	38.1	113.5	54.9	130.3	71.7	164.0	105.4
TSR 55	4	0	160.8	88.4	98.6	26.2	160.9	88.6	223.3	150.9	254.5	182.1	285.6	213.3	348.0	275.6
	4	1	180.9	99.5	87.5	6.1	149.9	68.5	212.2	130.8	243.4	162.0	274.6	193.2	336.9	255.5
	4	2	201.0	110.5	-	-	138.8	48.4	201.2	110.7	232.4	141.9	263.5	173.1	325.9	235.4
	4	3	221.1	121.6	-	-	127.8	28.3	190.1	90.6	221.3	121.8	252.5	153.0	314.8	215.3
TSR 70	4	4	241.2	132.6	-	-	116.7	8.2	179.1	70.5	210.3	101.7	241.4	132.9	303.8	195.2
	4	0	256.4	141.0	157.4	42.0	256.8	141.4	356.3	240.9	406.0	290.6	455.7	340.3	555.2	439.8
	4	1	288.5	158.6	139.7	9.9	239.2	109.4	338.6	208.8	388.4	258.6	438.1	308.3	537.6	407.7
	4	2	320.5	176.3	-	-	221.6	77.3	321.0	176.8	370.7	226.5	420.5	276.2	519.9	375.7
TSR 100	4	3	352.6	193.9	-	-	203.9	45.3	303.4	144.7	353.1	194.5	402.8	244.2	502.3	343.6
	4	4	384.6	221.5	-	-	186.3	13.2	285.8	112.7	335.5	162.4	385.2	212.1	484.7	311.6
	4	0	354.0	194.7	217.7	58.4	355.1	195.8	492.6	333.3	561.3	402.0	630.0	470.7	767.5	608.2
	4	1	398.3	219.0	193.3	14.1	330.8	151.6	468.3	289.0	537.0	357.8	605.7	426.5	743.2	563.9
TSR 150	4	2	442.5	243.4	-	-	306.5	107.3	443.9	244.8	512.6	313.5	581.4	382.2	718.8	519.7
	4	3	486.8	267.7	-	-	282.1	63.1	419.6	200.5	488.3	269.3	557.0	338.0	694.5	475.4
	4	4	531.0	292.0	-	-	257.8	18.8	395.2	156.3	464.0	225.0	532.7	293.7	670.1	431.2
	4	0	482.0	265.1	296.0	79.1	483.1	266.1	670.1	453.2	763.6	546.7	857.1	640.2	1044.2	827.3
TSR 250	4	1	542.3	298.2	262.9	18.9	449.9	205.9	637.0	392.9	730.5	486.5	824.0	580.0	1011.0	767.0
	4	2	602.5	331.4	-	-	416.8	145.6	603.8	332.7	697.3	426.2	790.9	519.7	977.9	706.8
	4	3	662.8	364.5	-	-	383.6	85.4	570.7	272.4	664.2	366.0	757.7	459.5	944.8	646.5
	4	4	723.0	397.6	-	-	350.5	25.1	537.5	212.2	631.1	305.7	724.6	399.2	911.6	586.3
TSR 400	4	0	710.8	390.9	436.5	116.7	712.4	392.5	988.2	668.3	1126.1	806.2	1264.0	944.1	1539.8	1219.9
	4	1	799.7	439.8	387.7	27.8	663.5	303.6	939.3	579.4	1077.2	717.4	1215.1	855.3	1490.9	1131.1
	4	2	888.5	488.7	-	-	614.6	214.8	890.4	490.6	1028.3	628.5	1166.2	766.4	1442.1	1042.2
	4	3	977.4	537.5	-	-	565.7	125.9	841.6	401.7	979.5	539.7	1117.4	677.6	1393.2	953.4
TSR 250	4	4	1066.2	586.4	-	-	516.9	37.1	792.7	312.9	930.6	450.8	1068.5	588.7	1344.3	864.5
	2	0	312	202	1122	1012	1563	1453	2004	1894	2225	2115	2446	2336	2887	2777
	4	0	624	404	920	700	1361	1141	1802	1582	2023	1803	2244	2024	2685	2465
	6	0	936	606	718	388	1159	829	1600	1270	1821	1491	2042	1712	2483	2153
TSR 400	8	0	1248	808	-	-	957	517	1398	958	1619	1179	1840	1400	2281	1841
	10	0	1560	1010	-	-	-	-	1196	646	1417	867	1638	1088	2079	1529
	12	0	1872	1212	-	-	-	-	-	-	1215	555	1436	776	1877	1217
	8	0	1456	944	1458	946	2258	1746	3059	2547	3459	2947	3859	3347	4660	4148
TSR 400	10	0	1820	1180	1222	582	2022	1382	2823	2183	3223	2583	3623	2983	4424	3784
	12	0	2184	1416	-	-	1786	1018	2587	1819	2987	2219	3387	2619	4188	3420
	14	0	2548	1652	-	-	1550	654	2351	1455	2751	1855	3151	2255	3952	3056
	15	0	2730	1770	-	-	-	-	2233	1273	2633	1673	3033	2073	3834	2874
16	0	2912	1888	-	-	-	-	2115	1091	2515	1491	2915	1891	3716	2692	

ACT | ACC

**MOTORISATION PNEUMATIQUE
PNEUMATIC ACTUATION**

Couples de manœuvre simple effet Spring return operating torques

Taille Actionneur MODELE Model	Nb Ressort Springs		Courbe ressort Spring stroke		Pression d'Alimentation (bar) - Air supply (bar)											
	Ext	Int	Début Start	Fin End	3 bars		4 bars		5 bars		5.5 bars		6 bars		7 bars	
TSR 3	1	1	2.6	1.3	10.5	9.2	14.4	13.2	18.4	17.1	20.4	19.1	22.3	21.1	26.3	25.0
	2	2	5.2	2.7	9.2	6.6	13.1	10.5								

**MOTORISATION PNEUMATIQUE
PNEUMATIC ACTUATION**

Nomenclature Type "S" "S" Type Components

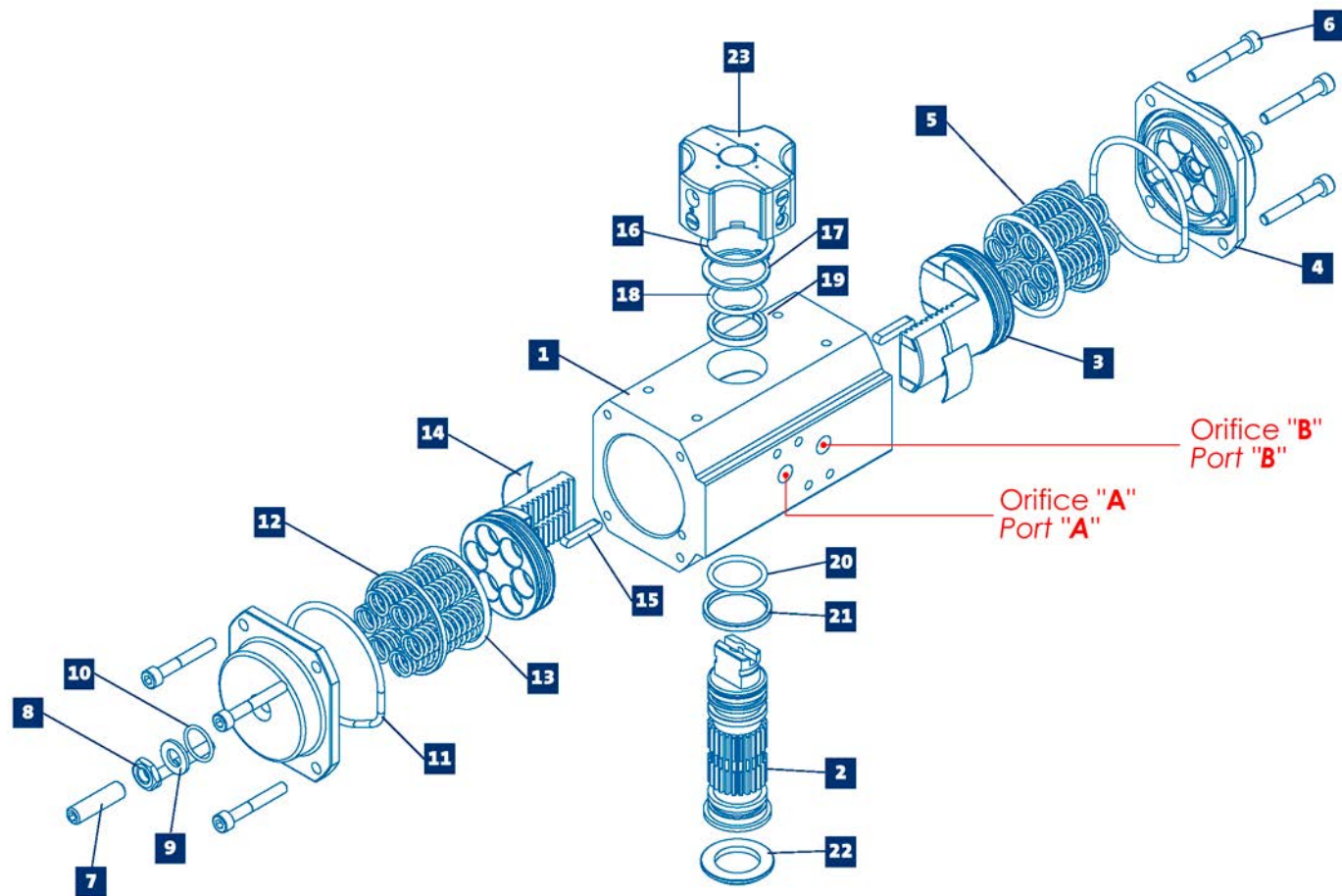

Ref	Description	Qt	Matière C et E	Matière CNI®	Description
1	Corps	1	Alum. Anodisé	Alum/CNI 530T	Cylinder
2	Axe	1	Acier / Steel	Acier inoxydable / S.S.	Driveshaft
3	Piston	2	Alum. Anodisé	Alum/CNI 425	Piston
4	Capot	1	Alum. Anodisé	Alum/CNI 530T	Endcap
5	Ressort	12 max		SiCr	Spring
6	Vis des capots	8	Acier inoxydable / Stainless Steel		Endcap bolt
7	Vis de butée	1	Acier haute tension / High tensile steel		Stop Adjustment Bolt
8	Ecrous de vis de butée	1	Acier haute tension / High tensile steel		Stop Adjustment Nut
9	Rondelle de vis de butée	1	Polyéthylène / Polyethylene		Stop Adjustment Washer
10	O-ring de vis de butée	1	Buna Nitrile		Stop Adjustment 'O' Ring
11*	O-ring des capots	2	Buna Nitrile		Endcap 'O' ring
12*	Joint arrière de piston	2	Delrin POM / POM Delrin		Piston Back-up Bearing
13*	O-ring des pistons	2	Buna Nitrile		Piston 'O' ring
14*	Patin de guidage du piston	2	Acier / Steel	Acier inoxydable / S.S.	Piston Wear Pad
15*	Barre de guidage de piston	2	Acier / Steel	Acier inoxydable / S.S.	Piston Guide bar
16*	Rondelle de guidage de tige	1	Polyéthylène / Polyethylene		Driveshaft Washer
17*	Circlip de tige	1	Acier / Steel	Acier inoxydable / S.S.	Driveshaft Circlip
18*	O-ring supérieur axe	1	Buna Nitrile		Driveshaft upper 'O' ring
19*	Guidage supérieur axe	1	Delrin POM / POM Delrin		Driveshaft upper bearing
20*	O-ring inférieur axe	1	Buna Nitrile		Driveshaft lower 'O' ring
21*	Guidage inférieur axe	1	Delrin POM / POM Delrin		Driveshaft lower bearing
22	Anneau de centrage	1	Delrin POM / POM Delrin		Centralization Ring
23	Indicateur de position	1	Nylon		Truvison Puck Indicator

* Articles inclus dans le kit de pièces de rechange / Items included in repair kits

**MOTORISATION PNEUMATIQUE
PNEUMATIC ACTUATION**

Dimensions actionneur type "S" Overall dimensions "S" type

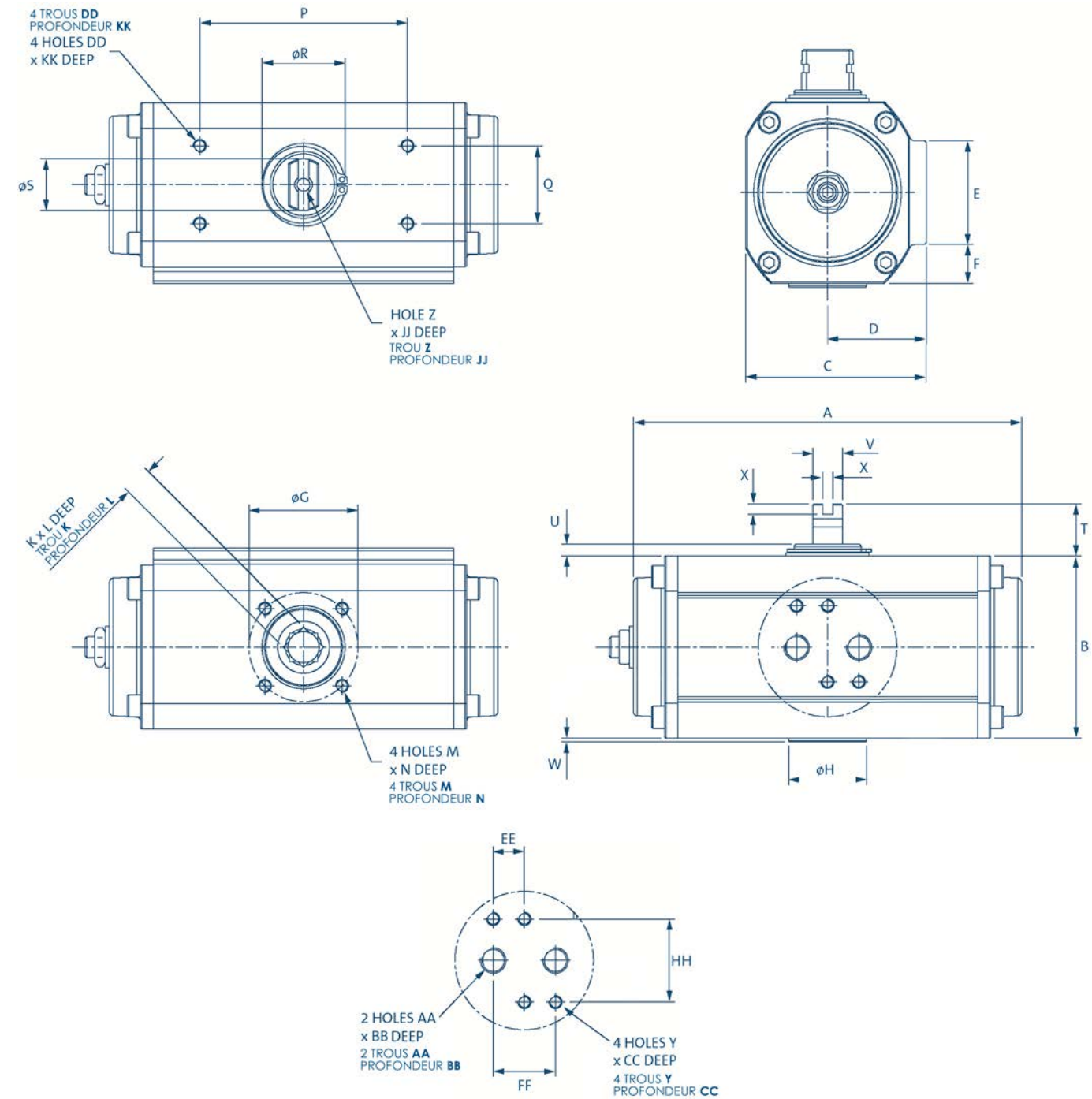

ISO 5211	A	B	C	D	E	F	ØG	H	J	K	L	M	N	P	Q	ØR	ØS
TT 3	F04	149.5	70.0	69.5	38.0	40.0	15.0	42.0	30.0	23.0	11.0	12.0	M5	8.0	80.0	30.0	20.0
TT 5	F05	186.5	87.0	90.5	49.0	40.0	26.5	50.0	35.0	34.5	14.0	15.0	M6	10.0	80.0	30.0	20.0

ISO 5211	T	U	V	W	X	Y	Z	AA	BB	CC	DD	EE	FF	GG	HH	JJ	KK	
TT 3	F04	20.0	4.5	11.5	1.5	4.0	M5	M6	G1/8"	10.0	8.0	M5	12.0	24.0	16.0	32.0	12.0	8.0
TT 5	F05	20.0	4.5	11.5	3.0	4.0	M5	M6	G1/8"	10.0	8.0	M5	12.0	24.0	16.0	32.0	12.0	8.0

ACT | ACC

**MOTORISATION PNEUMATIQUE
PNEUMATIC ACTUATION**

Nomenclature Type "E / C" "E/C" Type Components

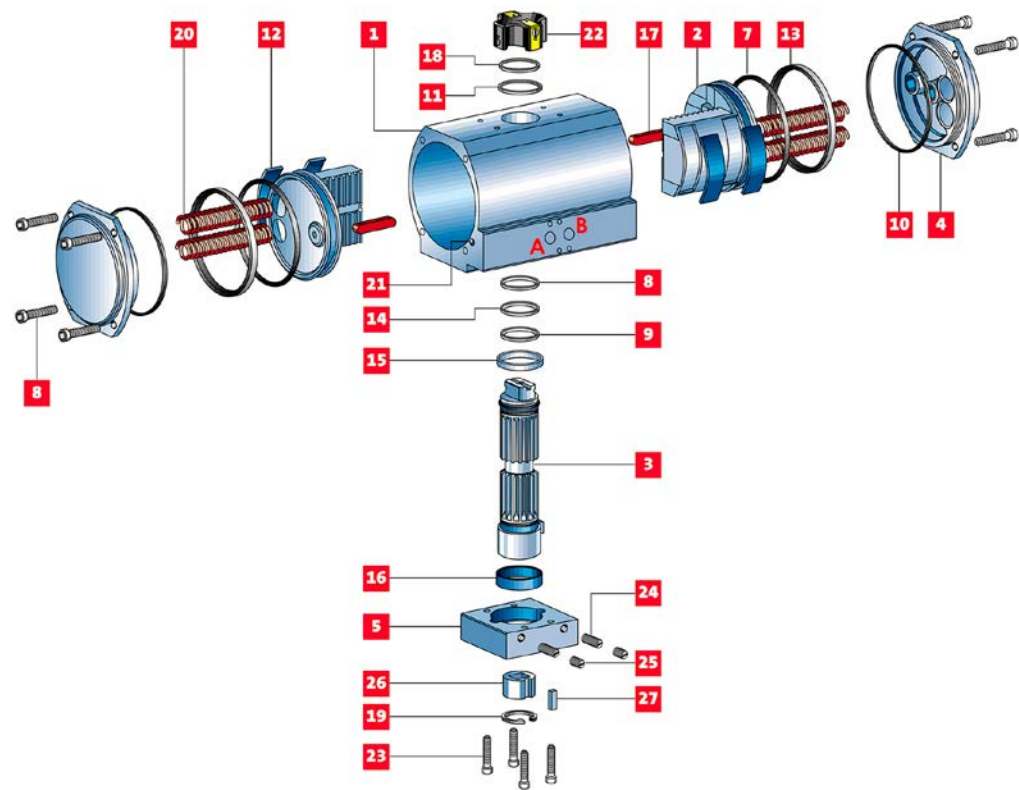

Ref	Description	Qt	Matière C et E	Matière CNI®	Description
1	Corps	1	Alum. Anodisé	Alum/CNI 530T	Cylinder
2	Piston	2	Alum. Anodisé	Alum/CNI 425	Piston
3	Axe	1	Acier / Steel	Acier inoxydable / S.S.	Driveshaft
4	Capot	2	Alum. Anodisé	Alum/CNI 530T	Endcap
5	Platine d'adaptation (BAK)	1	Alum. Anodisé	Alum/CNI 530T	Body adaptor
6	Vis des capots	8	Acier inoxydable / Stainless Steel		Endcap bolt
7*	O-ring des pistons	2	Buna Nitrile		Piston 'O' ring
8*	O-ring supérieur axe	1	Buna Nitrile		Driveshaft upper 'O' ring
9*	O-ring inférieur axe	1	Buna Nitrile		Driveshaft lower 'O' ring
10*	O-ring des capots	2	Buna Nitrile		Endcap 'O' ring
11*	Rondelle	1	Polyéthylène / Polyethylene		Washer
12*	Patin de guidage	4	Delrin POM / POM Delrin		Wear pads
13*	Rondelle de maintien	2	Delrin POM / POM Delrin		Backup bearing
14*	Guidage supérieur axe	1	Delrin POM / POM Delrin		Driveshaft upper bearing
15*	Guidage inférieur axe	1	Delrin POM / POM Delrin		Driveshaft lower bearing
16*	Guidage axe dans BAK	1	Delrin POM / POM Delrin		Body adaptor bearing
17*	Barre de guidage	2	Acier / Steel	Acier inoxydable / S.S.	Driveshaft Circlip
18*	Circlip supérieur	1	Acier / Steel	Acier inoxydable / S.S.	Guide bar
19	Circlip inférieur	1	Acier / Steel	Acier inoxydable / S.S.	Circlip upper
20	Ressort	4	SiCr		Spring
21*	Bille de contact	2	Composite		Ball bearing
22	Indicateur TruVision	1	Delrin POM / POM Delrin		TruVision indicator
23	Vis de la platine BAK	4	Acier inoxydable / Stainless Steel		Body adaptor bolt
24	Vis de réglage	2	Acier haute tension / High tensile steel		Stop adjustment screws
25	Vis de blocage	2	Acier / Steel		Lock screws
26	Insert d'adaptation	1	Acier inoxydable / Stainless Steel		Insert sleeve
27	Clavette de l'insert	1	Acier à clavette / Keysteel		Insert sleeve key

* Articles inclus dans le kit de pièces de rechange / Items included in repair kits

**MOTORISATION PNEUMATIQUE
PNEUMATIC ACTUATION**

Dimensions actionneur type "E" Overall dimensions "E" type

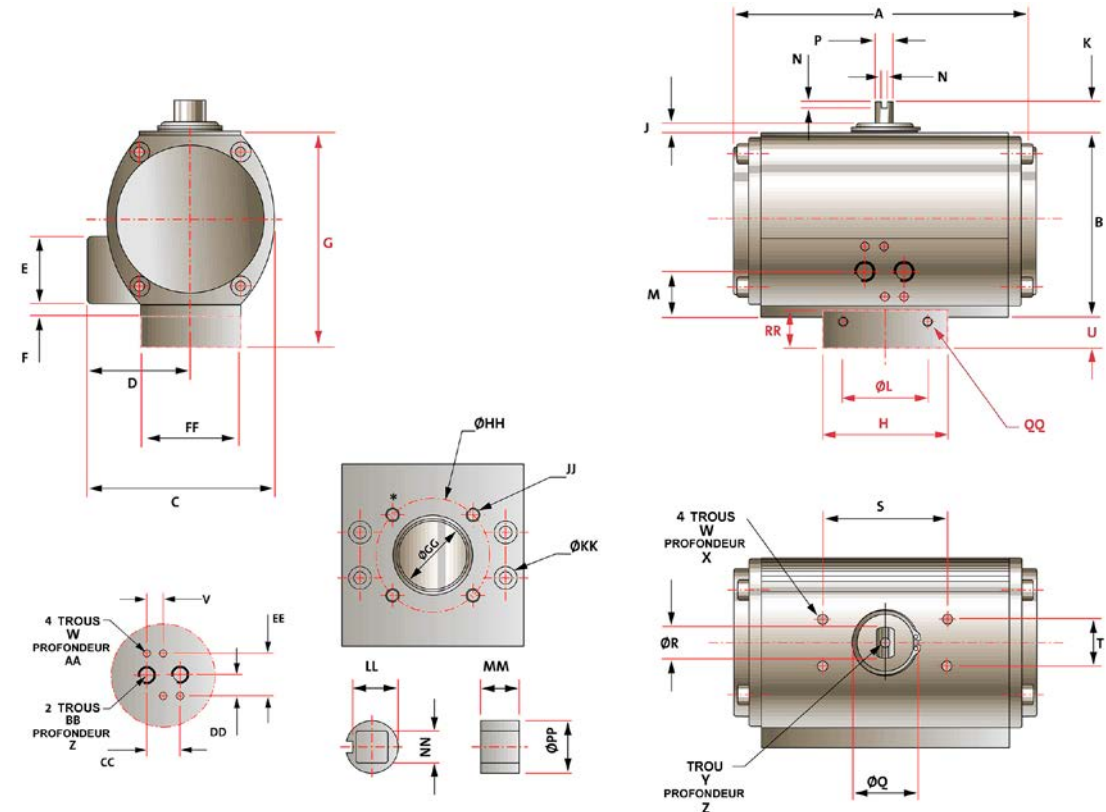

	ISO 5211	A	B	C	D	E	F	G	H	J	K	ØL	M	N	P	ØQ	ØR	S	T	U
TT 8	F05	162.0	109.0	105.0	57.0	42.0	7.5	127.0	80.0	5.0	20.0	35.0	27.0	4.0	11.5	35.0	20.0	80.0	30.0	18.0
TT 8	F07	162.0	109.0	105.0	57.0	42.0	7.5	127.0	80.0	5.0	20.0	35.0	27.0	4.0	11.5	35.0	20.0	80.0	30.0	18.0
TT 12	F05	194.0	118.5	121.0	67.0	43.0	8.0	138.5	80.0	5.5	20.0	35.0	29.5	4.0	11.5	46.0	20.0	80.0	30.0	20.0
TT 12	F07	194.0	118.5	121.0	67.0	43.0	8.0	138.5	80.0	5.5	20.0	35.0	29.5	4.0	11.5	46.0	20.0	80.0	30.0	20.0
TT 20	F07	218.0	140.5	136.5	72.0	43.0	8.0	164.5	90.0	6.5	20.0	55.0	29.5	4.0	19.0	50.0	32.0	80.0	30.0	24.0
TT 35	F07	266.0	166.5	156.0	78.0	43.0	8.5	196.7	120.0	7.0	30.0	55.0	30.0	4.0	19.0	61.0	32.0	80.0	30.0	30.2
TT 35	F10	266.0	166.5	156.0	78.0	43.0	8.5	196.7	120.0	7.0	30.0	55.0	30.0	4.0	19.0	61.0	32.0	80.0	30.0	30.2
TT 55	F10	312.0	207.5	191.0	95.5	43.0	20.5	242.5	140.0	7.5	30.0	85.0	42.0	4.0	25.4	61.0	40.0	130.0	30.0	35.0
TT 55	F12	312.0	207.5	191.0	95.5	43.0	20.5	242.5	140.0	7.5	30.0	85.0	42.0	4.0	25.4	61.0	40.0	130.0	30.0	35.0
TT 70	F10	340.0	211.0	191.0	95.5	43.0	20.5	247.0	140.0	7.0	30.0	85.0	42.0	4.0	25.4	72.0	40.0	130.0	30.0	36.0
TT 70	F12	340.0	211.0	191.0	95.5	43.0	20.5	247.0	140.0	7.0	30.0	85.0	42.0	4.0	25.4	72.0	40.0	130.0	30.0	36.0
TT 100	F14	361.0	253.3	227.0	113.5	43.0	39.5	303.0	160.0	7.0	30.0	100.1	61.0	4.0	25.4	78.0	40.0	130.0	30.0	49.8
TT 150	F14	390.0	302.0	280.0	140.0	43.0	56.5	351.0	160.0	7.0	30.0	100.1	78.0	4.0	25.4	78.0	40.0	130.0	30.0	49.0

	V	W	X	Y	Z	AA	BB	CC	DD	EE	FF	ØGG	ØHH	JJ	ØKK	LL	MM	NN	ØPP	QQ	RR
TT 8	12.0	M5	5.0	M6	12.0	8.0	G1/8"	24.0	16.0	32.0	79.9	30.0	50.0	M6	5.5	20.0	17.0	14.0	23.0	M5	22.0
TT 8	12.0	M5	5.0	M6	12.0	8.0	G1/8"	24.0	16.0	32.0	79.9	47.0	70.0	M8	5.5	29.5	17.0	17.0	33.0	M6	24.0
TT 12	12.0	M5	5.0	M6	12.0	8.0	G1/4"	24.0	16.0	32.0	79.9	30.0	50.0	M6	5.5	20.0	17.0	14.0	23.0	M5	22.0
TT 12	12.0	M5	5.0	M6	12.0	8.0	G1/4"	24.0	16.0	32.0	79.9	47.0	70.0	M8	5.5	29.5	17.0	17.0	33.0	M6	24.0
TT 20	12.0	M5	5.0	M6	12.0	8.0	G1/4"	24.0	16.0	32.0	89.9	46.0	70.0	M8	6.6	29.5	20.0	17.0	33.0	M8	28.0
TT 35	12.0	M5	5.0	M6	12.0	8.0	G1/4"	24.0	16.0	32.0	119.9	46.0	70.0	M8	9.0	29.5	20.0	17.0	33.0	M10	34.0
TT 35	12.0	M5	5.0	M6	12.0	8.0	G1/4"	24.0	16.0	32.0	119.9	61.0	70.0	M10	9.0	39.0	25.0	22.0	44.0	M10	34.0
TT 55	12.0	M5	5.0	M6	12.0	8.0	G1/4"	24.0	16.0	32.0	139.9	61.0	102.0	M10	11.0	39.0	25.0	22.0	44.0	M10	40.0
TT 55	12.0	M5	5.0	M6	12.0	8.0	G1/4"	24.0	16.0	32.0	139.9	75.0	125.0	M12	11.0	50.0	25.0	27.0	55.0	M10	40.0
TT 70	12.0	M5	5.0	M6	12.0	8.0	G1/4"	24.0	16.0	32.0	139.9	61.0	102.0	M10	11.0	39.0	25.0	22.0	44.0	M10	40.0
TT 70	12.0	M5	5.0	M6	12.0	8.0	G1/4"	24.0	16.0	32.0	139.9	75.0	125.0	M12	11.0	50.0	25.0	27.0	55.0	M10	40.0
TT 100	12.0	M5	5.0	M6	12.0	8.0	G1/4"	24.0	16.0	32.0	159.9	88.0	140.0	M16	14.0	62.5	35.0	36.0	68.0	M14	57.0
TT 150	12.0	M5	5.0	M6	12.0	8.0	G1/4"	24.0	16.0	32.0	159.9	88.0	140.0	M16	14.0	62.5	35.0	36.0	68.0	M14	57.0

MOTORISATION PNEUMATIQUE
PNEUMATIC ACTUATION

Dimensions actionneur type "C" "C" type Overall dimensions

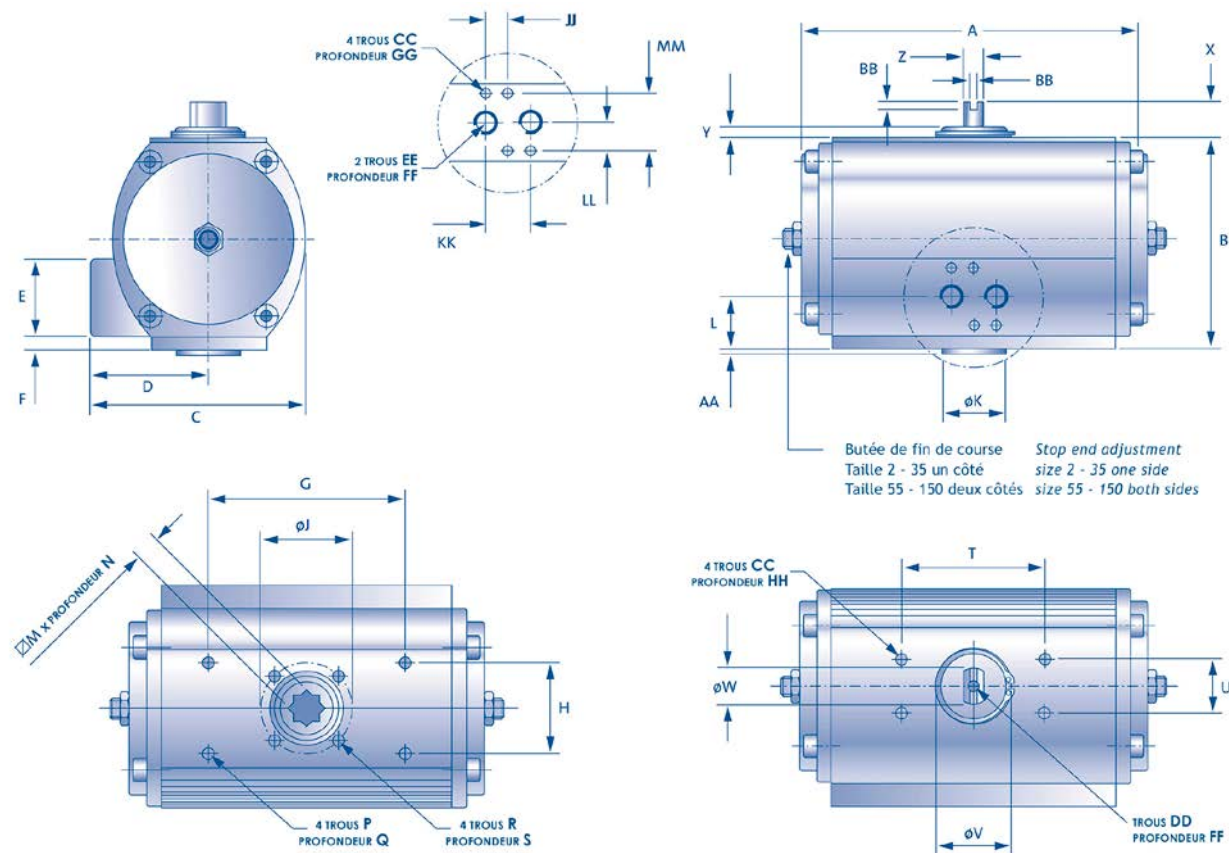

ISO 5211	A	B	C	D	E	F	G	H	ØJ	ØK	L	M	Nmin	P	Q	R	S	T	
TT 8	F05/F07	162.0	109.0	105.0	57.0	42.0	7.5	73.0	32.0	50.0	35.0	28.5	14.0	16.0	M6	10.0	M6	10.0	80.0
TT 12	F07	194.0	118.5	121.0	67.0	43.0	8.0	107.0	49.0	70.0	55.0	29.5	17.0	19.0	M6	10.0	M8	12.0	80.0
TT 20	F07	218.0	140.5	136.5	72.0	43.0	8.0	107.0	49.0	70.0	55.0	29.5	17.0	19.0	M6	10.0	M8	13.0	80.0
TT 35	F10	266.0	166.5	156.0	78.0	43.0	8.5	161.0	73.0	102.0	70.0	30.0	22.0	24.0	M6	12.0	M10	16.0	80.0
TT 55	F12	312.0	207.5	191.0	95.5	43.0	20.5	161.0	73.0	125.0	85.0	42.0	27.0	29.0	M8	15.0	M12	20.0	130.0

ISO 5211	U	ØV	ØW	X	Y	Z	AAmax	BB	CC	DD	EE	FF	GG	HH	JJ	KK	LL	MM	
TT 8	F05/F07	30.0	35.0	20.0	20.0	5.0	11.5	3.0	4.0	M5	M6	G1/8"	12.0	8	5	12	24	16	32
TT 12	F07	30.0	46.0	20.0	20.0	5.5	11.5	3.0	4.0	M5	M6	G1/4"	12.0	8	5	12	24	16	32
TT 20	F07	30.0	50.0	32.0	20.0	6.5	19.0	3.0	4.0	M5	M6	G1/4"	12.0	8	5	12	24	16	32
TT 35	F10	30.0	61.0	32.0	20.0	7.0	19.0	3.0	4.0	M5	M6	G1/4"	12.0	8	5	12	24	16	32
TT 55	F12	30.0	61.0	40.0	30.0	7.5	25.4	3.0	4.0	M5	M6	G1/4"	12.0	8	5	12	24	16	32

ISO 5211	A	B	C	D	E	F	G	H	ØJ	K	L	M	N	P	Q	R	S	T	
TT 250	F16	248.0	300.0	280.0	140.0	-	56.0	244.0	117.0	165.0	-	-	46.0	-	M12	22.0	M20	32.0	200.0

ISO 5211	U	ØV	ØW	ØX	Y	Z	AA	BB	CC	DD	EE	FF	GG	HH	JJ	KK	LL	MM	
TT 250	F16	90.0	120.0	60.0	50.0	14.0	36.0	-	4.0	M5	-	G1/4"	12.0	8	12	12	24	16	32

ISO 5211	A	B	C	D	E	F	G	H	ØJ	K	L	M	N	P	Q	R	S	T	
TT 400	F16	300.0	385.0	360.0	180.0	-	53.0	244.0	117.0	165.0	-	-	55.0	-	M12	22.0	M20	35.0	200.0

ISO 5211	U	ØV	ØW	ØX	Y	Z	AA	BB	CC	DD	EE	FF	GG	ØHH	JJ	KK	LL	MM	
TT 400	F16	90.0	120.0	60.0	60.0	20.0	36.0	-	4.0	M5	-	G1/4"	12.0	8	12	12	24	16	32

MOTORISATION ÉLECTRIQUE
ELECTRIC ACTUATION

Présentation EZ 4 à EZ 60

Couple 45 à 600 N.m

EZ 4 to EZ 60 presentation

Torque 45 to 600N.m

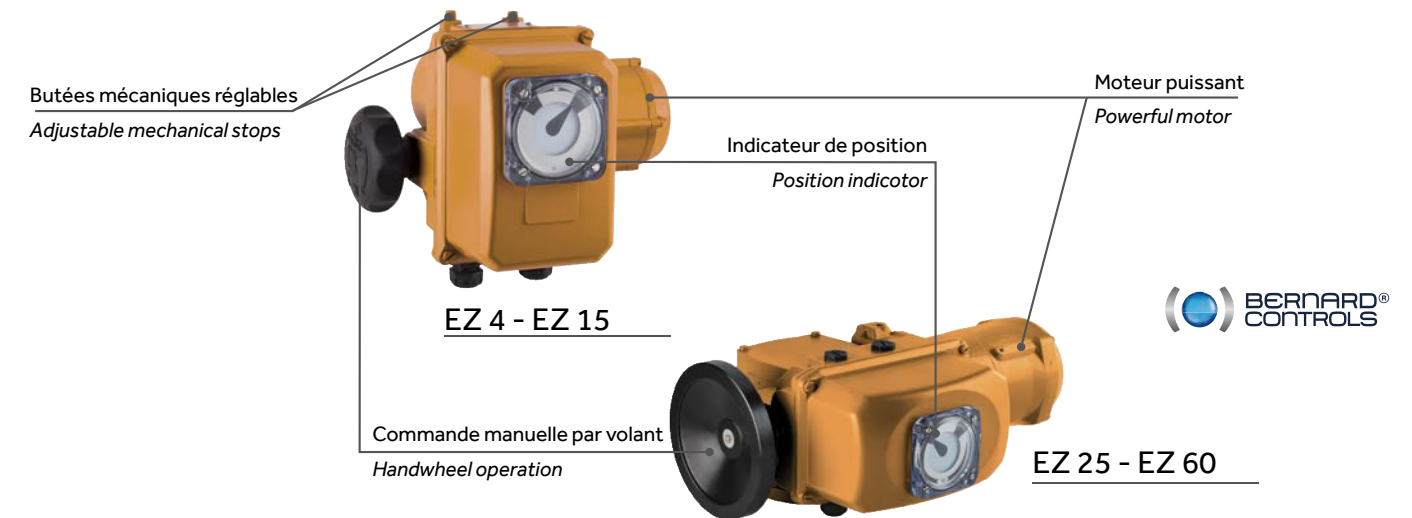

Spécifications générales	
Général	Les servomoteurs EZ intègrent un moteur avec protection thermique, une chaîne cinématique, une commande manuelle de secours, des contacts de fin de course et de limiteurs d'effort (sauf de EZ4 à EZ15) ainsi qu'une douille d'entraînement amovible
Chaîne cinématique	Les chaînes cinématiques sont mécaniquement irréversibles et sont lubrifiées pour toute la durée de vie du produit
Endurance	De EZ4 à EZ60 : 20 000 cycles (en tout ou rien) / 300 000 démarrages (positionnement) De EZ100 à EZ1000 : 10 000 cycles (en tout ou rien) / 200 000 démarrages (positionnement) Testé pour EN15714-2 classe A & B
Enveloppes	Carter en aluminium, cathaphorèse et peinture époxy RAL 1017 IP67
Technologie moteur	Moteur mono ou triphasé à cage d'écureuil de type totalement fermé, isolation classe F avec protection thermique incorporée
Facteur de marche moteur	S4-25 % suivant CEI 60034-1. 360 démarrages par heure au maximum
Plage de température	-20 °C à +60 °C / -4 °F à +140 °F
Indicateur de position	Indicateur de position mécanique pour une information continue de position, y compris en cas de coupure de l'alimentation électrique
Connexions électriques	Borniers à vis pour la commande et la puissance. Borne de masse interne
Entrées de câbles	2 M20 fermées par des bouchons
Conformités aux directives et standards	Les servomoteurs sont conformes aux directives CE 2004/108/EC, 2006/95/EC et aux standards EN 61000-6-4, EN 61000-6-2, EN 60034-1 et EN 60529

General specifications	
General	EZ actuators include motor with thermal protection, gear case, emergency handwheel, travel limit switches, torque switches (except EZ4 to EZ15) anti-condensation heater, and output drive with removable socket
Gear design	Gears are mechanically self-locking and are lubricated for product lifetime
Design life	EZ4 to EZ60: 20,000 cycles (On-Off) / 300,000 starts (Positioning) EZ100 to EZ1000: 10,000 cycles (On-Off) / 200,000 starts (Positioning) Tested to EN15714-2 Class A & B
Enclosures	Actuator housing in aluminium die casting, cathaphoresis & epoxy paint RAL 1017 IP67
Motor technology	Totally-enclosed, squirrel cage 3-phase or 1-phase motor, class F insulation with integral thermal overload protection.
Motor duty	S4-25% motor duty rating to IEC 60034-1. 360 starts/hour in peak
Temperature range	-20°C to +60°C / -4°F to +140°F
Position indication	Mechanical position indicator for a continuous indication even in the event of power supply loss
Electrical connection	Screw-type terminals for controls and power supply. Internal earth grounding post
Cable entries	2 x M20 sealed by caps
Compliance with Directives & Standards	Actuators comply with: EC directives 2004/108/EC, 2006/95/EC and standards EN 61000-6-4, EN 61000-6-2, EN 60034-1 and EN 60529

**MOTORISATION ÉLECTRIQUE
ELECTRIC ACTUATION**

Caractéristiques de fonctionnement

Basic operating details

Commande Tout ou Rien	
Système de fin de course	4 contacts SPDT ; 250 VAC-16 A / 48VDC-2.5 A max. (charge résistive)
Système de limitation de couple	Le système de limitation de couple donnent un contact de courte durée (sauf EZ4 à EZ15) 2 contacts SPDT ; 250 VAC-16 A / 48 VDC-2.5 A max. (charge résistive)
Indication de recopie de position (option)	Potentiomètre 1 000 Ohms, 0.3 W – courant curseur = max. 1 mA. Transmetteur de position " TAM " : 4-20 mA (12, 24 ou 32 V) pour une charge maximale admissible de 150, 750 ou 1050 Ohms

On-Off controls	
Travel limit system	4 SPDT contacts ; 250 VAC-16 A / 48 VDC-2.5 Amax. (resistive load)
Torque limiting system	The torque limit switch gives a short duration contact. (except EZ4 to EZ15) 2 contacts as standard ; SPDT ; 250VAC-16A / 48 VDC-2.5 Amax. (resistive load)
Remote position signal (option)	1000 Ohm potentiometer, 0.3 W - wiper current = max. 1 mA. "TAM" position transmitter: 4-20 mA (12, 24 or 32V) power supply for maximum permissible load of 150, 750 or 1050 Ohms

Positionnement avec les commandes intégrées Minigam	
Précision du positionnement	Mieux que 2 % Bande morte réglable par potentiomètre
Commande (consigne)	Signal d'entrée configurable (impédance): 4-20 mA (260 Ohms) / 0-20 mA (260 Ohms) / 0-10 V (10 K Ohms)
Information de retour de position	Signal sortant identique au signal entrant (i.e signal d'entrée : 4-20 mA – signal de sortie : 4-20 mA) 4-20 mA (300 Ohms max.) / 0-20 mA (300 Ohms max.) / 0-10 V (5 K Ohms min.) 2 contacts SPDT ; 250 VAC-16 A / 48 VDC-2.5 Amax. (charge résistive)
Protections intégrées	Protection par fusible - Protection thermique moteur - Protection par limiteur de couple (EZ25 et au-dessus)

Positioning with Minigam integrated controls	
Positioning precision	Better than 2%. Dead band adjustable by potentiometer
Command (set-point)	Configurable input signal (input impedance): 4-20 mA (260 Ohms) / 0-20 mA (260 Ohms) / 0-10 V (10 K Ohms)
Position feedback	Output signal identical to the input signal (i.e, input signal: 4-20 mA – output signal: 4-20 mA) 4-20 mA (300 Ohms max.) / 0-20 mA (300 Ohms max.) / 0-10 V (5 K Ohms min.) 2 SPDT contacts ; 250 VAC-16 A / 48 VDC-2.5 Amax. (resistive load)
Integrated protections	Fuse protection - Motor thermal protection - Torque limiter protection (EZ25 and above)

1x230 VAC 50 Hz								
						Moteur Service S4 – Service : 25 % Motor - S4 service - Duty rating: 25%		
Modèle	Couple max N.m	Disponible en version Minigam	Couple de positionnement	Temps de manoeuvre s / 90°	Bride ISO	Puissance kW	Courant nominal A	Courant démarrage A
Type	Max torque N.m	Available in Minigam version	Positioning torque	Operating time s / 90°	Flange ISO	Power kW	Current rated A	Current start A
EZ4	45	non	-	6	F05/F07	0.03	0.8	0.9
EZ6	60	non	-	6	F05/F07	0.03	0.6	0.9
EZ10	100	non	-	6	F05/F07	0.06	1.2	1.7
EZ10	100	oui	50 N.m	35	F05/F07	0.02	0.5	0.6
EZ15	150	oui	75 N.m	25	F05/F07	0.03	0.6	0.9
EZ25	250	oui	125 N.m	30	F07/F10	0.03	0.6	0.9
EZ60	600	oui	250 N.m	30	F07/F10	0.06	1.2	1.7
3x400 VAC 50 Hz								
EZ6	60	non	-	6	F05/F07	0.03	0.3	0.5
EZ10	100	non	-	6	F05/F07	0.1	0.6	1.1
EZ15	150	non	-	25	F05/F07	0.03	0.3	0.5
EZ25	250	non	-	30	F07/F10	0.03	0.3	0.5
EZ60	600	non	-	30	F07/F10	0.06	0.3	0.8

**MOTORISATION ÉLECTRIQUE
ELECTRIC ACTUATION**

Dimensions type "EZ"

Overall dimensions "EZ" type

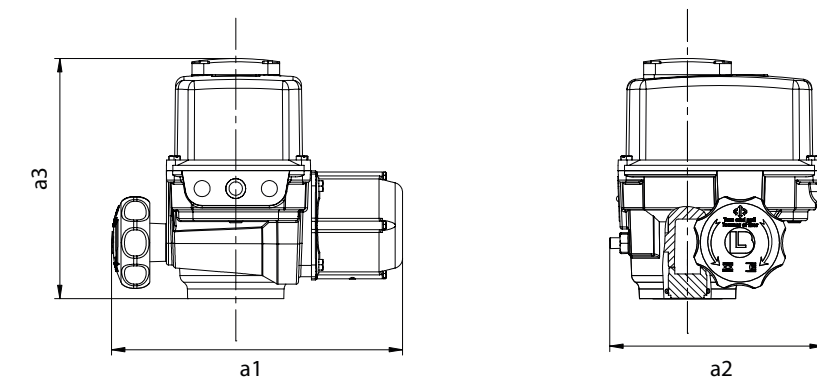

	Bride Flange ISO5211	Taille tige / Stem size (mm)		a1 max. (mm)	a2 (mm)	a3 (mm)	Poids Weight (kg)
		Alésage / Bore (max.)	Carré / Square (max.)				
EZ4	F05/F07	22	19	273	200	225	6
EZ6	F05/F07	22	19	319	200	225	7
EZ10	F05/F07	22	19	362	200	225	7
EZ15	F05/F07	22	19	362	200	225	7

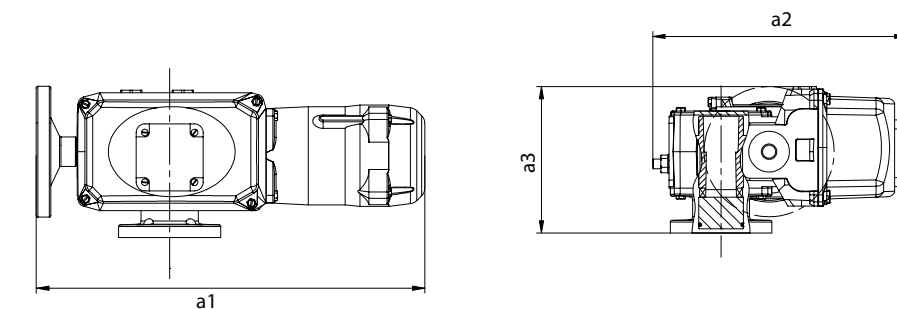

	Bride Flange ISO5211	Taille tige / Stem size (mm)		a1 max. (mm)	a2 (mm)	a3 (mm)	Poids Weight (kg)
		Alésage / Bore (max.)	Carré / Square (max.)				
EZ25	F07/F10	30	22	479	313	180	18
EZ60	F07/F10	32	27	528	313	180	20

Sur demande :
Autre tension
Version ATEX

On request:
Other voltage
ATEX version

Contacts fin de course / Electro distributeurs *Limit switches / Solenoid valves*

Classes de protection
IP 65 / IP66 / IP 67
Protection en Zone ATEX
Eex "ia"
Eex "ed"
Eex "em"
ATEX II2 G/D

Classes of protection
IP 65 / IP66 / IP 67
ATEX zone protection
Eex "ia"
Eex "ed"
Eex "em"
ATEX II2 G/D



Bloc détecteurs
Inductive sensors



Electrodistributeur Eex "ia"
Eex "ia" solenoid valve



Electrodistributeur Eex "em"
Eex "em" solenoid valve



Boîtier fin de course Eex "ed"
Eex "ed" limit switch box

ACT | ACC

**ZONE SAINE
SAFE AREA**

Boîtier fin de course | BML102



Protection
IP66

Boîtier
Polycarbonate avec console inox VDI/VDE 3845

Raccordement
Presse-étoupe M20 x 1.5 pour câble de diamètre 8 à 12 mm.
Second presse-étoupe pour raccordement électrovanne en option.

Signalisation
2 micro-rupteurs Crouzet SPDT (ouvert ou fermé)

Indication de position
Dôme sur boîtier (ouvert / fermé)

Données techniques
Tension d'alimentation : Maxi 250 V, 50 Hz
Intensité du courant : Maxi 16 A
T° d'utilisation : -20 °C à +90 °C

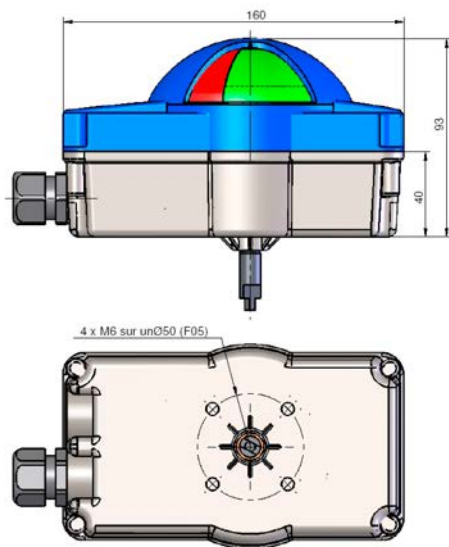

Limit switch box | BML102

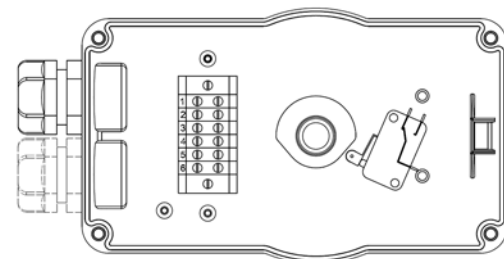

Protection
IP66

Housing
Polycarbonate and stainless steel bracket according
VDI/VDE 3845

Cabling
Gland entry M20x 1.5 for 8 to 12mm cable.
Second gland entry for solenoid cabling on request

Signaling
2 micro switches Crouzet SPDT (Open or Closed)

Position Indication
On the top of the box (Open/Closed)

Technical data
Voltage : 250V, 50Hz Maxi
Current : 16A Maxi
Temperature : -20°C à +90°C

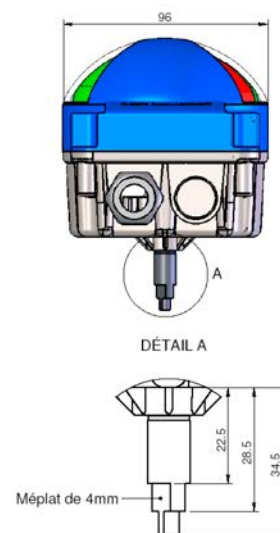

**ZONE SAINE
SAFE AREA**

Electrodistributeur ASCO | JCG551



Electrodistributeur Série G551
Distributeur 5/2-3/2 à tiroir
Corps en aluminium anodisé
Fluide moteur : air, gaz neutres filtrés
Pression d'alimentation : 2 à 10 bars
Débit d'air (Qv à 6 bars) : 700 L/min.
Température : -25 °C à +60 °C
Protection IP65
Commande manuelle de secours à vis

Pilote IP65
Type: SCG551A001 MS
Tensions : 24 VC, 24 VA, 115 VA, 230 VA 50 Hz
Presse-étoupe M20 x 1.5

Solenoid valve ASCO | JCG551

Solenoid valves G551 type
5/2-3/2 body
Body in anodized aluminium
Supply: air, neutral gaz (filtered)
Pressure: 2 to 10 bars
Air flowrate (Qv at 6 bars): 700L/min.
Temperature: -25°C to +60°C
Housing IP65
Manual override

IP65 pilot
Type: SCG551A001 MS
Voltages: 24VDC, 24VAC, 115VAC, 230VAC 50Hz
Gland entry M20 x 1.5

ZONE SAINE
SAFE AREA

Bloc détecteurs | IN5285



Protection
IP67

Capteurs
2 Capteurs surmoulés résistant aux chocs et vibrations
VDI/VDE 3845

Raccordement
Connecteur M 18

Signalisation
Deux détecteurs normalement ouverts avec came de détection

Indication de position
2 LED jaunes

Données techniques
Tension d'alimentation : 10 à 36 VDC
Courant de sortie : 250 mA
Température d'utilisation : -20 °C à +80 °C

Sur demande
Autres types de détecteurs IFM

Inductive sensors | IN5285



Protection
IP67

Sensors
2 sensors moulded in PBTP.
Shocks and vibrations resistant
VDI/VDE 3845

Cabling
M 18 connector

Signaling
2 inductive sensors normally open with target puck

Position Indication
2 yellow LED

Technical data
Voltage: 10 to 36 VDC
Current: 250mA
Temperature : -20°C to +80°C

On request
Other types of IFM sensors

ZONE ATEX
ATEX AREA

Eex"ia" Limit switch box | BVL430

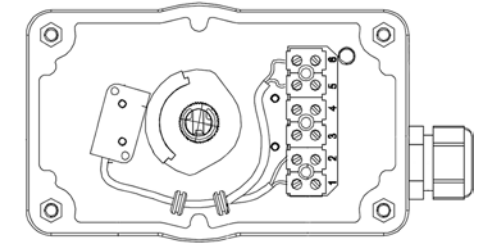

Protection
Intrinsically Safe: Eex "ia" II CT6
Enclosure: IP 66
ATEX compliance II 2 G

Housing
In Vestamid box with stainless steel bracket to VDI/VDE 3845

Cabling
Gland entry in ATEX polyamid, M20x 1.5 for cable of 8 to 12mm (other size upon request)
Second gland entry for solenoid valve Eex "i" cabling, upon request.

Signaling
2 inductive sensors IFM NS5002

Position Indication
On the top of the box (Open / Closed)

Technical data
Voltage: 8VDC
Current: NAMUR
Temperature: -20°C à + 40°C

Boîtier fin de course Eex"ia" | BVL430

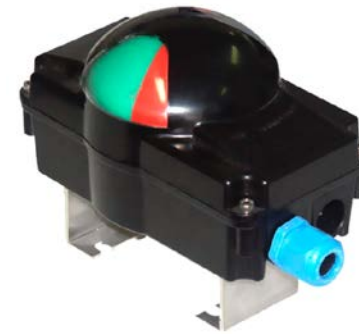

Protection
Sécurité intrinsèque: Eex " ia " II CT 6
Boîtier : IP 66
Conformité ATEX II 2 G

Boîtier
Vestamid avec console inox VDI/VDE 3845

Raccordement
Presse-étoupe : polyamide ATEX, M20 x 1.5 pour câble de 8 à 12 mm (autre sur demande).
Second Presse étoupe pour raccordement d'une électrovanne Eex " i " en option

Signalisation
2 détecteurs de proximité IFM type NS5002

Indication de position
Dôme sur boîtier (ouvert / fermé)

Données techniques
Tension alimentation : 8 VC
Intensité du courant : NAMUR
Température d'utilisation : -20 °C à +40 °C

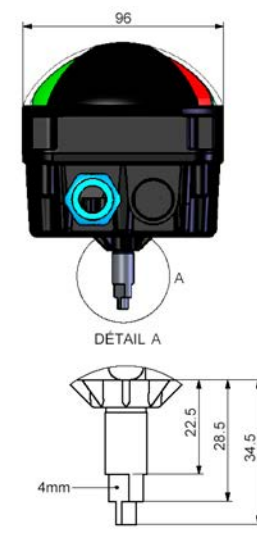
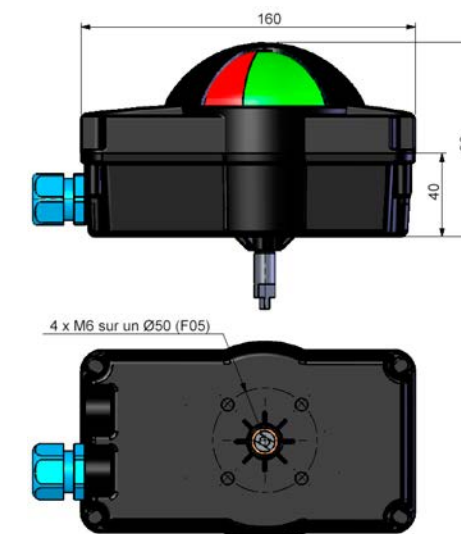

ZONE ATEX
ATEX AREA

Electrodistributeur Eex "ia" BÜRKERT



Electrodistributeur Série 6519
Distributeur 5/2-3/2 à clapet
Commande manuelle de secours à vis
Corps en polyamide
Fluide moteur : air, gaz neutres filtrés
Pression d'alimentation : 2 à 8 bars
Débit d'air (Qv à 6 bars) : 900 L/min.
Température : -20 °C à +55 °C
Protection IP65

Pilote Eex"ia"
ATEX 94/9/CE II2G Eex"ia" 2C T6
Tension : 24 VC
Presse-étoupe M20 x 1.5

Eex"ia" solenoid valve BÜRKERT

Solenoid valves 6519 type
5/2-3/2 body
Emergency operation with screw
Body in polyamid
Supply: air, neutral gaz (filtered)
Pressure: 2 to 8 bars
Air flowrate (Qv at 6 bars): 900L/min.
Temperature: -20°C to +55°C
Housing IP65

Eex"ia" pilot
ATEX 94/9/CE II2G Eex"ia" 2C T6
Voltage: 24VDC
Gland entry M20 x 1.5

ZONE ATEX
ATEX AREA

Bloc détecteurs Eex"ia" | NN5013



Protection
Sécurité intrinsèque Eex"ia" IICT6.
ATEX 94/9/CE II2GD
IP67 (projections eau, air, poussière)

Capteurs
2 Capteurs surmoulés résistant aux chocs et vibrations
VDI/VDE 3845

Raccordement
Connecteur M 18

Signalisation
Deux détecteurs normalement fermés avec came de détection

Indication de position
2 LED jaunes

Données techniques
Tension d'alimentation : 7.5 à 15 VC
Tension nominale : 8.2 VC (Namur)
Intensité du courant : < 1 mA (non commuté)
> 2.1 mA (commuté)
Température d'utilisation : -20 °C à +70 °C

Sur demande
Autres types de détecteurs IFM

Inductive sensors Eex"ia" | NN5013



Protection
Intrinsically safe Eex"ia" IICT6.
ATEX 94/9/CE II2GD
IP67 (splatters of water, air, dust)

Sensors
2 sensors moulded in PBTP.
Shocks and vibrations resistant VDI/VDE 3845

Cabling
M 18 connector

Signaling
2 inductive sensors normally close with target puck

Position Indication
2 yellow LED

Technical data
Voltage : 7.5 to 15 VDC
Nominal voltage: 8.2VDC (Namur)
Current: < 1mA (damped)
> 2.1mA (undamped)
Temperature : -20°C à +70°C

On request
Other types of IFM sensors

ZONE ATEX
ATEX AREA

Boîtier fin de course Eex" ed " | BVL730



Protection
Sécurité augmentée : Eex " ed " IIC T6
Boîtier : IP 66
Conformité ATEX II2 GD

Boîtier
Vestamid avec arcade inox VDI/VDE 3845

Raccordement
Presse-étoupe : M20 x 1.5 pour câble de 8 à 12 mm
Second Presse étoupe pour raccordement d'une élec-
trovanne en option

Signalisation
2 microinterrupteurs Crouzet SPDT Eex " d "

Indication de position
Dôme sur boîtier

Données techniques
Tension alimentation : Maxi 250 VA
Intensité du courant : 5 A max.
Température d'utilisation : -20 °C à +60 °C

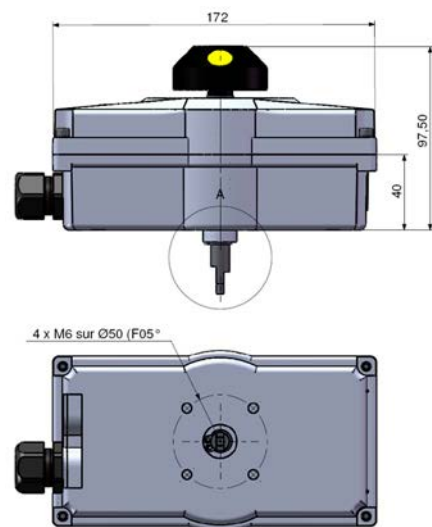

Eex"ed" Limit switch box | BVL730

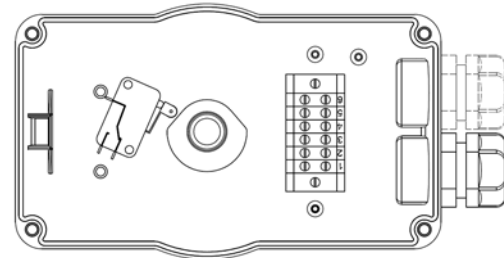

Protection
Explosionproof Eex "ed" IIC T6
Enclosure: IP 66
ATEX II2 GD compliance

Housing
In Vestamid box with stainless steel bracket to VDI/VDE
3845

Cabling
Gland entry: M20x 1.5 for cable of 8 to 12mm
Second gland entry for solenoid valve cabling, upon
request.

Signaling
2 micro switches Crouzet type SPDT Eex "d"

Position Indication
On the top of the box

Technical data
Voltage: 250VAC
Current: 5A max.
Temperature: -20°C à + 60°C

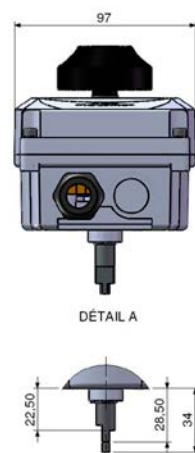

ZONE ATEX
ATEX AREA

Electrodistributeur Eex " em " BÜRKERT



Electrodistributeur Série 6519
Distributeur 5/2-3/2 à clapet
Commande manuelle de secours à vis
Corps en polyamide
Fluide moteur : air, gaz neutres filtrés
Pression d'alimentation: 2 à 8 bars
Débit d'air (Qv à 6 bars): 900 L/min.
Température : -20 °C à +55 °C
Protection IP65

Pilote Eex" em "
ATEX 94/9/CE II2GD Eex " em " T6
Tensions : 24 VC, 24 VA, 115 VA, 230 VA 50 Hz
Presse-étoupe M20 x 1.5

Eex"em" solenoid valve BÜRKERT

Solenoid valve 6519 type
5/2-3/2 function
Manual override
Body in polyamid
Supply: air, neutral gaz (filtered)
Pressure: 2 to 8 bars
Air flowrate (Qv at 6 bars): 900L/min.
Temperature: -20°C to +55°C
Housing IP65

Eex"em" pilot
ATEX 94/9/CE II2GD Eex"em" T6
Voltages: 24VDC, 24VAC, 115VAC, 230VAC 50Hz
Gland entry M20x1.5

ZONE ATEX
ATEX AREA

Électrodistributeur ASCO Eex "d"
G551LPKF



Electrodistributeur Asco G551 LPKF
Distributeur 5/2 ou 3/2
Commande manuelle de secours à vis
Corps et pilote en aluminium
Fluide moteur : air, gaz neutres filtrés
Pression d'alimentation : 2 à 10 bars
Débit d'air (Qv à 6 bars) : 900 L/min..
Température : -25 °C à +60 °C
Protection IP67
Conformité CEI 335

Pilote Eex "d"
Protections : II2G Ex d IIB+H2 Gb T6
Tensions (Puissance) :
Courant continu : 24 VC, 48 VC
Courant alternatif 50 Hz : 24 VA, 48 VA, 115 VA, 230 VA
Livré avec presse étoupe pour câble non armé diamètres :
6 à 12 mm

Eex"d" solenoid valve ASCO
G551LPKF

Spool valve Asco G551 LPKF
5/2 and 3/2 function
Manual override
Aluminium body and operator
Supply: air, neutral gaz (filtered)
Pressure: 2 to 10 bars
Air flowrate (Qv at 6 bars): 900L/min.
Temperature: -25°C to +60°C (-40°F to +140°F)
IP67 Housing
CEI 335

Eex "d" operator
Protections: II2G Ex d IIB+H2 Gb T6
Voltage (Power):
DC: 24VCC, 48VCC
AC 50Hz: 24VAC, 48VAC, 115VAC, 230VAC
Delivered with gland packing for unarmored cable
diameter: 6 - 12mm

Autres solutions sur demande

Others solutions on request



Exemple
Boîtier fin de course avec
électrodistributeur intégré

Exemple
Limit switch box
including spooling
valve

DN 08 à 200

Pour robinets 3-pièces type PS4
Pour robinets 2-pièces type R2

Size 1/4" to 8"

For 3-piece ball valves PS4 type
For 2-piece ball valves R2 type



Solution d'arrêt d'urgence
Emergency shut-off solution



Levier rehaussé
Extended handle



Rehausse
Stem extension



Volant inox
Stainless steel handwheel

Rehausse

DN 10 à 50

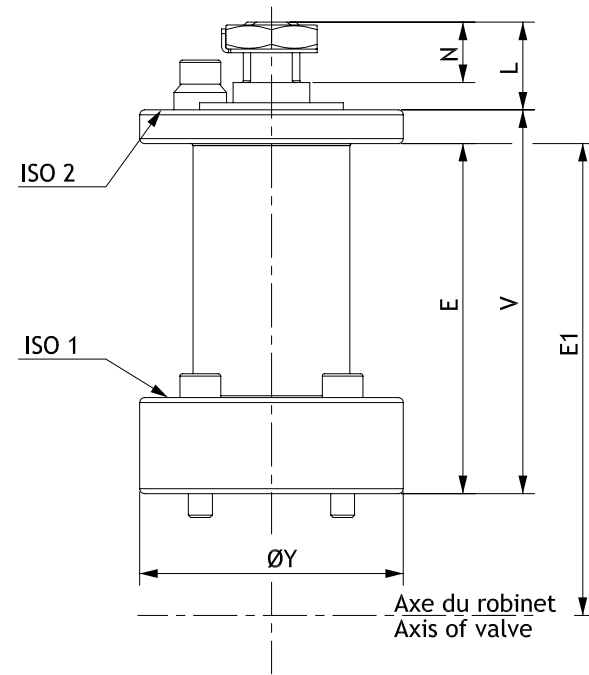

Stem extension

1/4" to 2"

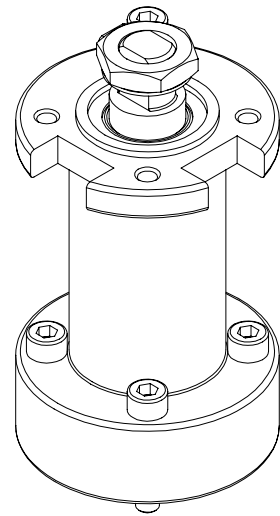

RH4 : Extension de tige en acier inoxydable sur laquelle, le calorifuge de tuyauterie peut être soudé. La platine supérieure reprend les dimensions ISO du robinet. Version pour montage de levier ou volant verrouillables.

RH4: Stainless steel stem extension on which pipe insulation, can be welded. Top of the extension similar to the valve ISO top flange. Lockable handwheel / lever

DN (PS4) Size (PS4)		DN (2P) Size (2P)		E	E1	L	N	V	ØY	ISO 1	ISO 2		
Nominal Full	Standard Reduced	Nominal Full	Standard Reduced										
10	1/4"-3/8"	15	1/2"	-	-	44	71.5	13.3	9.7	50	46	F03	F03
15	1/2"	20	3/4"	15	1/2"	44	75	13.3	9.7	50	46	F03	F03
20	3/4"	25	1"	20	3/4"	48	85.9	18.3	12.6	55	55	F04	F04
25	1"	32	1"1/4"	25	1/2"	48	90	18.3	12.6	55	55	F04	F04
32	1"1/4"	40	1"1/2"	32	1"1/4"	57	111	24.1	16.4	65	65	F05	F05
40	1"1/2"	50	2"	40	1"1/2"	57	116	24.1	16.4	65	65	F05	F05
50	2"	65	2"1/2"	50	2"	64	137	29.5	19	75	89.5	F07	F07

Rehausse

DN 10 à 150

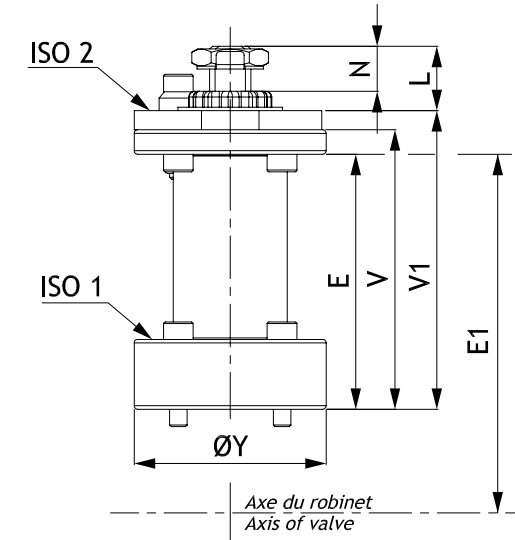

Stem extension

1/4" to 6"

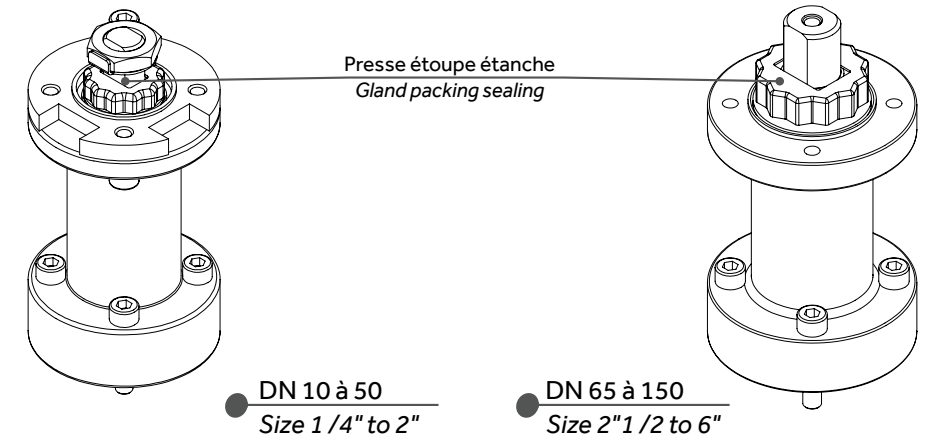

RHS : Version sans joint d'étanchéité entre la rehausse et le robinet.
RHT : Version avec joint d'étanchéité en PTFE entre la rehausse et le robinet.
RHJ : Version avec joint d'étanchéité par joint O-ring en fluorosilicone entre la rehausse et le robinet pour utilisation sur fluides thermiques.

RHS: without sealing between valve and extension.
RHT: PTFE sealing between valve and extension.
RHJ: Fluorosilicone O'ring sealing between valve and extension for thermal fluid.

PS4

DN - Size		E	E1	L	N	V	V1	ØY	ISO 1	ISO 2		
Nominal - Full	Standard - Reduced											
10	1/4"-3/8"	15	1/2"	74	101.5	13.4	8.7	80	85	46	F03	F03
15	1/2"	20	3/4"	74	105	13.4	8.7	80	85	46	F03	F03
20	3/4"	25	1"	73	110.9	18.4	12.6	80	85.5	55	F04	F04
25	1/2"	32	1"1/4"	73	115	18.4	12.6	80	85.5	55	F04	F04
32	1"1/4"	40	1"1/2"	92	146	24.2	16.2	100	109	65	F05	F05
40	1"1/2"	50	2"	92	151	24.2	16.2	100	109	65	F05	F05
50	2"	65	2"1/2"	89	162	29.6	19	100	108	90	F07	F07
65	2"1/2"	80	3"	105.5	209.5	43.2	25	120	-	90	F07	F07
80	3"	100	4"	105.5	219.5	43.2	25	120	-	125	F10	F10
100	4"	125	5"	102	235	48.7	30	120	-	125	F10	F10
125	5"	150	6"	136	297	58.2	32.5	150	-	150	F12	F12
150	6"	200	8"	136	316	58.2	32.5	150	-	150	F12	F12

R2

DN - Size		E	E1	L	N	V	V1	ØY	ISO 1	ISO 2
15	1/2"	74	105	13.4	8.7	80	85	46	F03	F03
20	3/4"	73	110.9	18.4	12.6	80	85.5	55	F04	F04
25	1"	73	115	18.4	12.6	80	85.5	55	F04	F04
32	1"1/4"	92	146	24.2	16.2	100	109	65	F05	F05
40	1"1/2"	92	151	24.2	16.2	100	109	65	F05	F05
50	2"	89	172	29.6	19	100	108	90	F07	F07
65	2"1/2"	105.5	209.5	43.2	25	120	-	90	F07	F07
80	3"	105.5	219.5	43.2	25	120	-	125	F10	F10
100	4"	102	235	48.7	30	120	-	125	F10	F10
150	6"	136	316	58.2	32.5	150	-	150	F12	F12

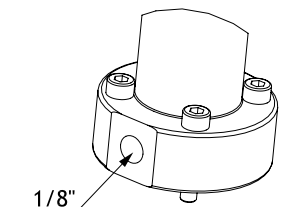

Option "D"
Trou taraudé en partie basse pour montage d'un manomètre. (détection de fuite)
Threaded hole to insert manometer. (leak detection)

Levier en inox cadenassable

DN 10 à 50

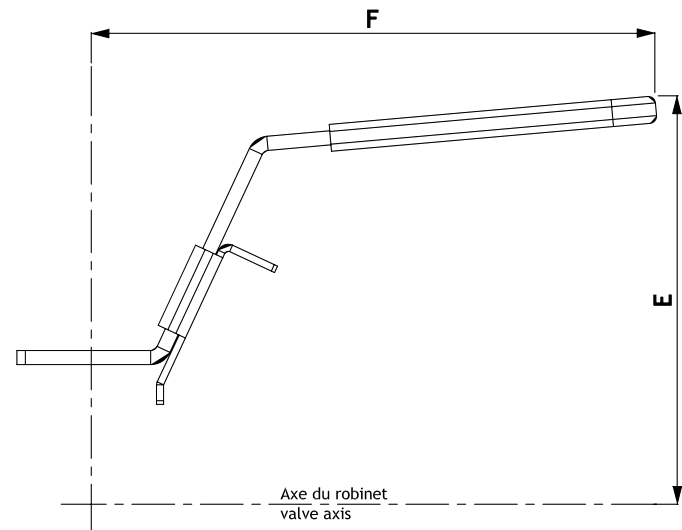

Stainless steel lockable handle

Size 1/4" to 2"

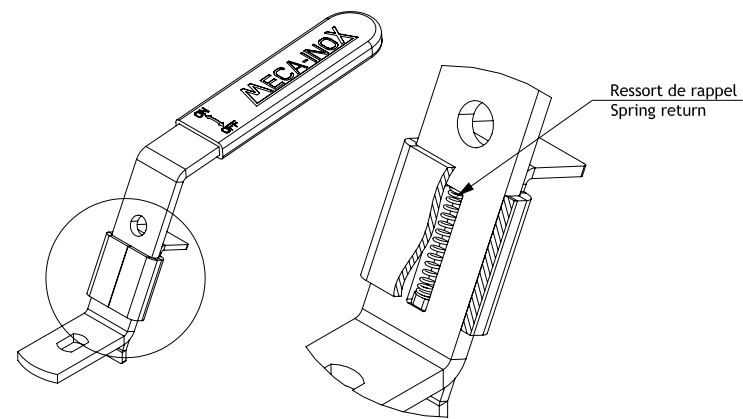

RR4NICV : Levier en inox 1.4301. Ce levier est équipé d'un système de verrouillage cadenassable avec ressort de rappel.

	DN - Size		BR4NICV PS4		RR4NICV PS4 - R2		
	Nominal Full	Standard Reduced	E	F	E	F	
10	1/4"-3/8"	15	1/2"	68	118	105.5 (PS4)	118
15	1/2"	20	3/4"	73	118	108.5	118
20	3/4"	25	1"	88	158	117.5	158
25	1"	32	1"1/4"	92	158	121.7	158
32	1"1/4"	40	1"1/2"	109	188	135.7	188
40	1"1/2"	50	2"	114	188	140.7	188
50	2"	65	2"1/2"	137	225	158.5 (PS4) 168.5 (R2)	225

RR4NICV: 304 stainless steel lever. Equipped with a spring lockable system.

BR4NICV: 304 stainless steel lever. Equipped with a lockable system. Mounting only for PS4 series.

Levier rehaussé

304L

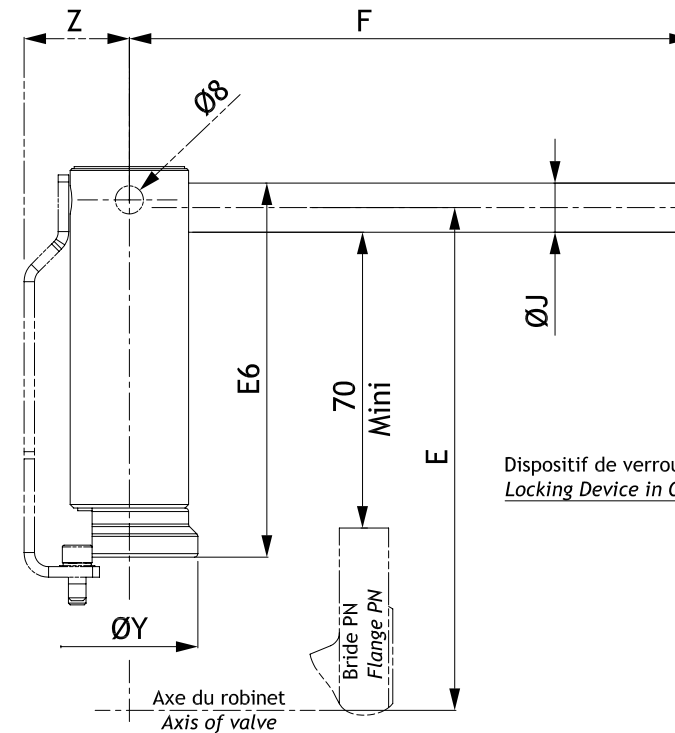

PLRJ4 : Levier rallongé en acier inoxydable utilisé sur les tuyauteries calorifugées.

Sur demande :
Version levier coulissant (PLRJ4 CL).
Dispositif de verrouillage (PLRJ4 CAD8).

Extended handle

304L

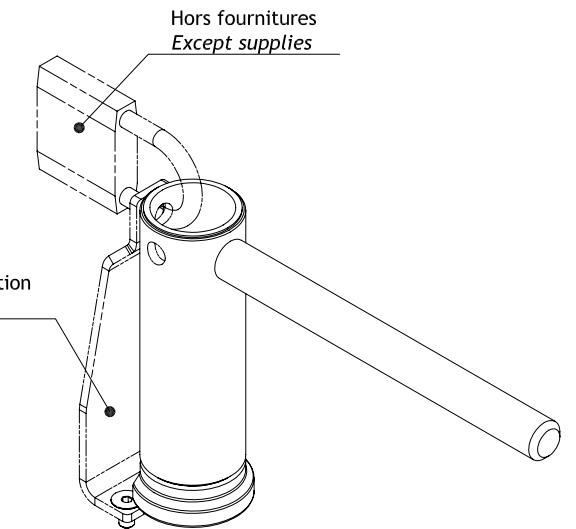

PLRJ4: Stainless steel extended lever for insulated pipes.

On request:
Sliding option (PLRJ4 CL).
Locking device (PLRJ4 CAD8).

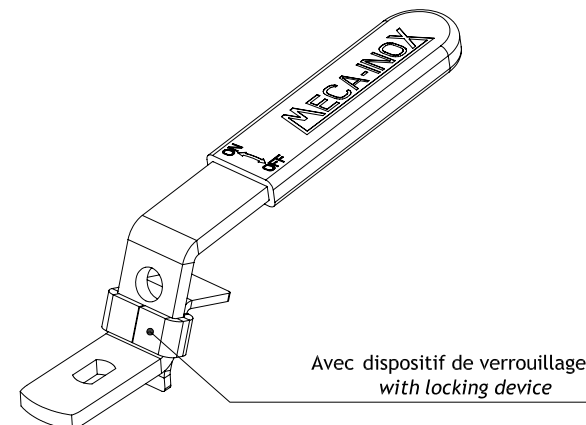
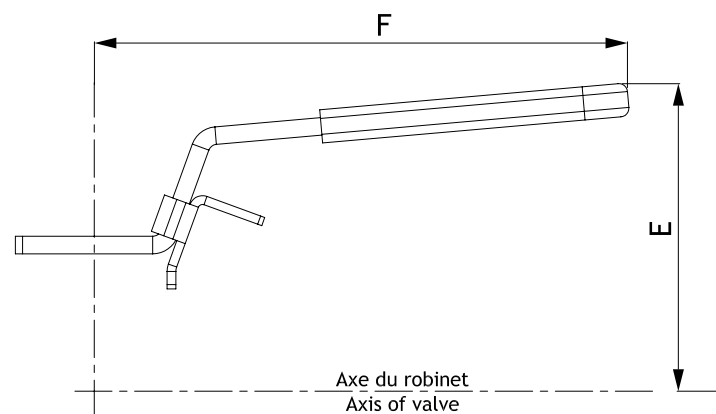

	DN Size		E		E6	F	ØJ	ØY	Z	
	Nominal Full	Standard Reduced	PS4	R2						
10	1/4"-3/8"	15	1/2"	128.9	-	104	120	12	37.5	27
15	1/2"	20	3/4"	133.7	133.7	104	120	12	37.5	27
20	3/4"	25	1"	143.2	143.2	106.5	160	14	39	30
25	1"	32	1"1/4"	147.3	147.3	106.5	160	14	39	30
32	1"1/4"	40	1"1/2"	156	156	102	190	16	47.5	33
40	1"1/2"	50	2"	161	161	102	190	16	48	33
50	2"	65	2"1/2"	180.6	190.6	106	224	18	64.5	46

Volant en inox

DN 10 à 50

RVONIRM / RVONICVRM

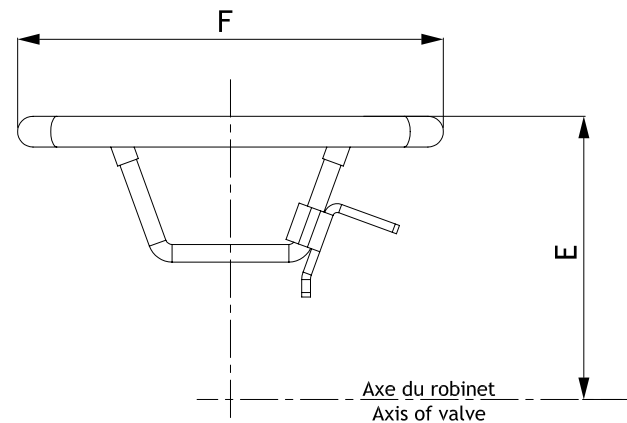

Stainless steel handwheel

Size 1/4" to 2"

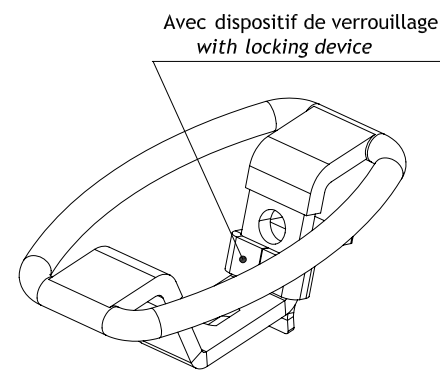

RVONIHM / RVONICVHM

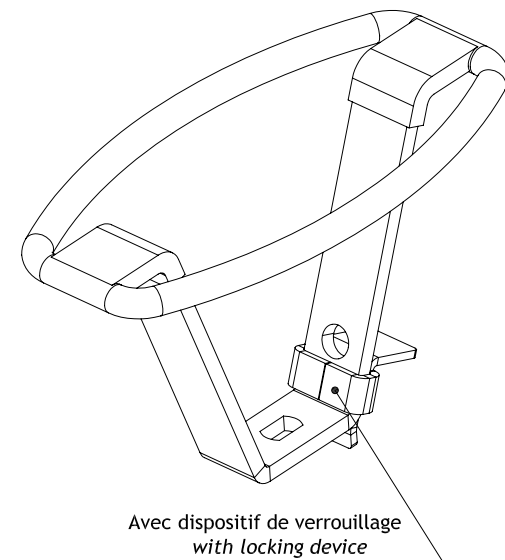
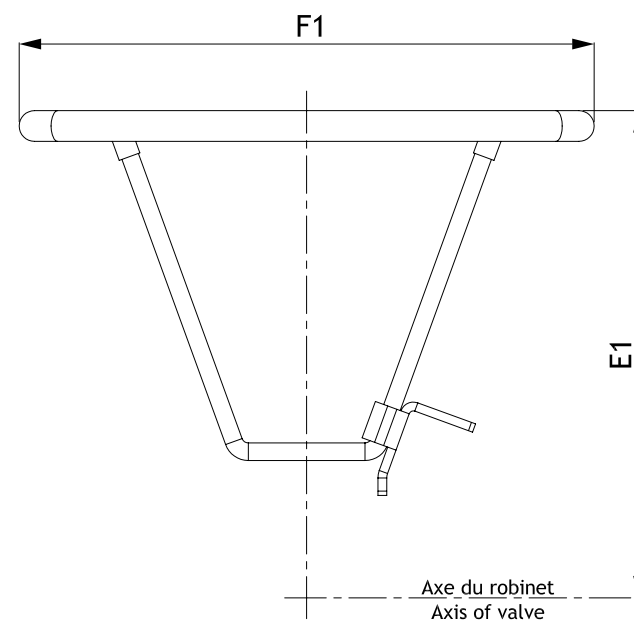

DN - Size				RVONIRM - RVONICVRM PS4 *		RVONIHM - RVONICVHM PS4		RVONIHM - RVONICVHM R2	
Nominal Full	Standard Reduced	E	F	E	F	E1	F1	E1	F1
10	1/4"-3/8"	15	1/2"	60	96 x 59	107	131 x 68	-	-
15	1/2"	20	3/4"	64	96 x 59	111	131 x 68	111	131 x 68
20	3/4"	25	1"	80	121 x 72	131	169 x 88	131	169 x 88
25	1"	32	1"1/4	85	121 x 72	135	169 x 88	135	169 x 88
32	1"1/4	40	1"1/2	-	-	156	209 x 109	156	209 x 109
40	1"1/2	50	2"	-	-	161	209 x 109	161	209 x 109
50	2"	65	2"1/2	-	-	174	243 x 148	184	243 x 148

*Pas de montage de volant version bas sur Rob 2P / No mounting on R2 ball valve

Levier rehaussé

P4NIRH

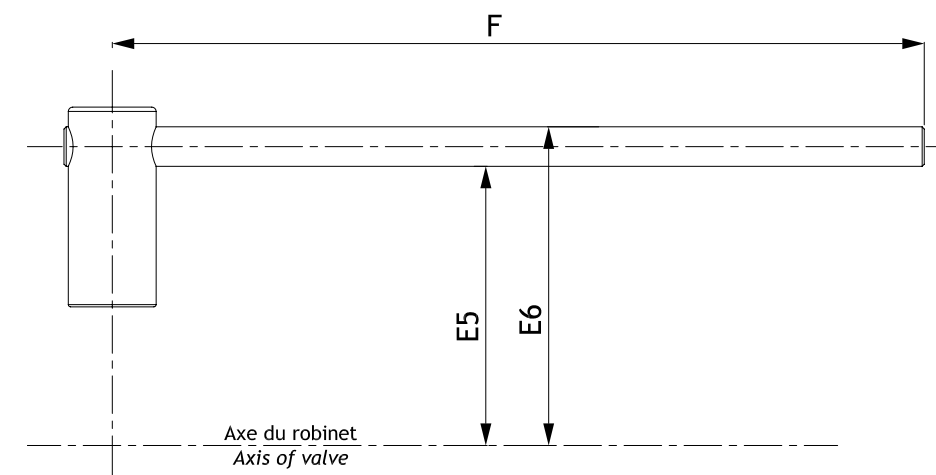

Extended handle

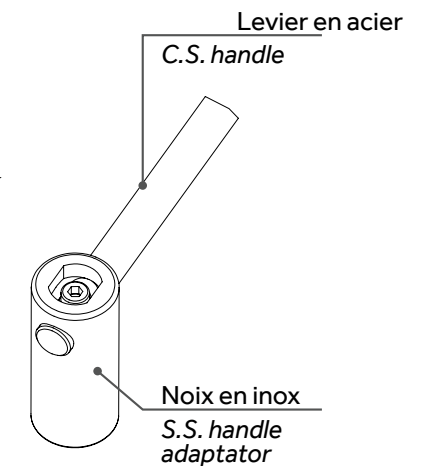

KCADI

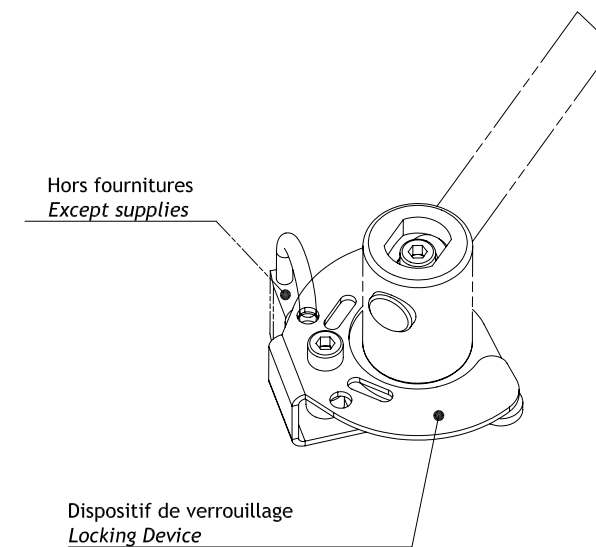

Dispositif de verrouillage pour levier P4NI et P4NIRH (inox)
Locking device for P4NI and P4NIRH handle (stainless steel)

DN - Size				P4NIRH					
Nominal Full	Standard Reduced	E5	E6	PS4		R2		F	
65	2"1/2	80	3"	194	212	370	194	212	370
80	3"	100	4"	204	222	440	204	222	440
100	4"	125	5"	235	255	505	235	255	505
125	5"	150	6"	263	290	700	-	-	-
150	6"	200	8"	282	309	700	282	309	700

SÉCURITÉ EN RETOUR DE POSITION
OPERATION SAFETY

Version manuelle

Manual version



Le levier avec ressort de rappel intégré, appelé "homme mort", apporte l'assurance d'une position de sécurité par défaut.

"Dead-man" lever ball valves: a spring box is assembled on the valve and switch the valve into safety position as soon as the operator releases the handle.

Version motorisation pneumatique

Pneumatic actuation version



Un actionneur simple effet à retour par ressort, fermera le robinet en l'absence d'air comprimé. L'option ABOP intègre un débrayage de l'actionneur et permet une manœuvre manuelle par levier sécurisé.

A spring return actuator closes the valve any case of air power shutdown. ABOP option included an actuator release to allow safe manual operating.

SOLUTION D'ARRÊT EN URGENCE
EMERGENCY SHUT-OFF SOLUTION

Sécurité de retour en position

Operation safety

Ferme le robinet en cas d'urgence de manière automatique en cas d'incendie ou par une action manuelle. Ensemble autonome en énergie (pas besoin d'air comprimé ni d'alimentation électrique). La vanne est tenue en position ouverte par l'intermédiaire d'un loquet maintenant un ressort comprimé. Une action manuelle ou la fonte d'un fusible thermique libère le loquet entraînant la fermeture immédiate de la vanne.

Close ball valve in case of emergency: automatically (Fire) or manually. Energy-independent (no compressed air, no power). Valve is always maintained in the open position. - A locker keeps a spring loaded. Triggering by manual emergency action or where the thermal fuse melts (fire). - Unloading spring allows valve closing.

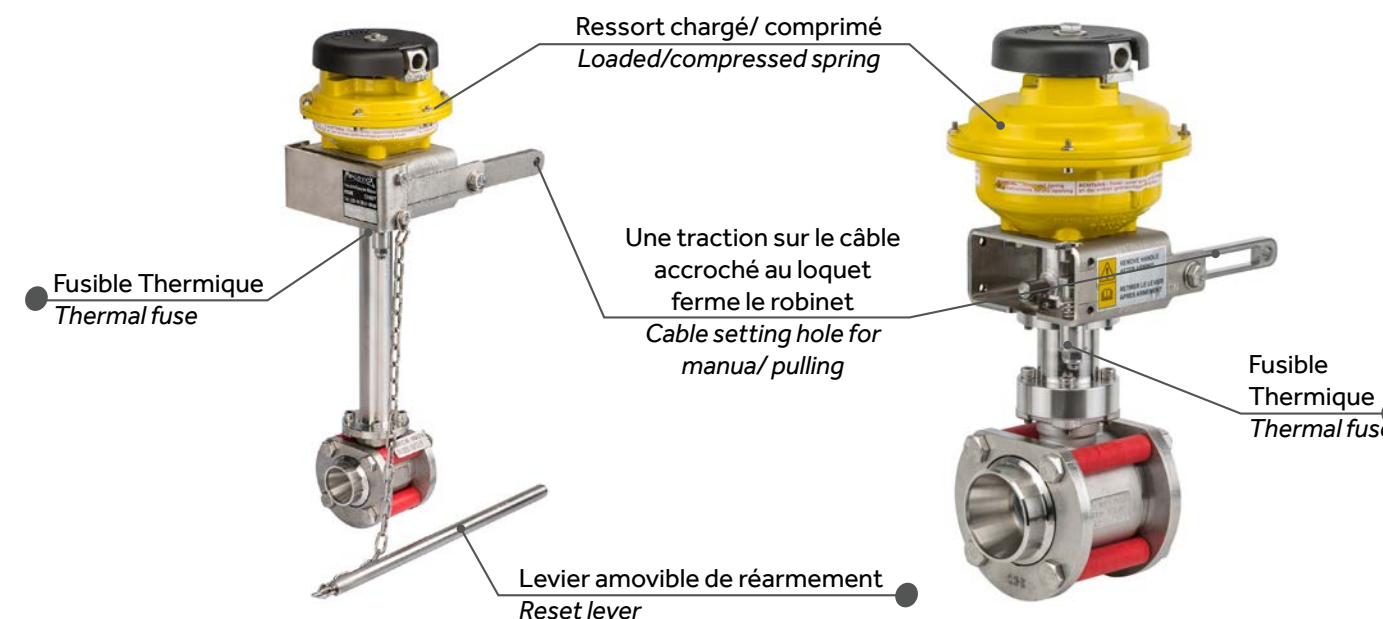

Manœuvre de secours des vannes motorisées

Emergency operation of the actuated valve

Ouverture progressive d'une vanne manuelle
Ouvrir / fermer des vannes à fort couple de manœuvre

Manual valve gradual opening
Open/close valves with high operating torque

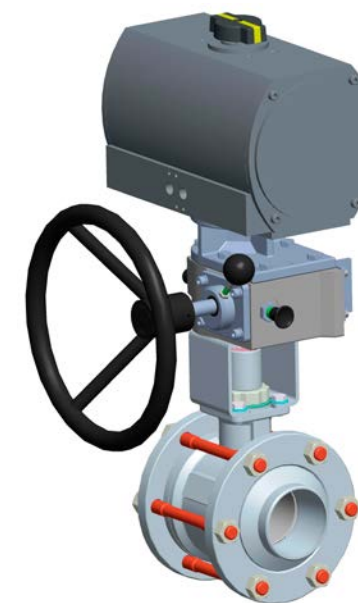

Pièces de rechange

Joint d'étanchéité
Sphère
Tige
Kit de ressorts

Spare parts list

Sealing components
Ball
Stem
Springs kit



PIECES DE RECHANGE
SPARE PARTS LIST

Pochettes de joints

Comprenant :
2 sièges
2 joints de corps
1 garniture de presse étoupe
1 rondelle de friction

Spare seats kits

Including:
2 seats
2 body seals
1 gland packing
1 stem thrust seal

DN Intégral <i>Full bore</i>	DN Standard <i>Reduced bore</i>	PS4	PZ4	PP4	PY4	PY4 CY
		TFM 1600	PTFE +20%PEEK +20%PEEK PTFE	PEEK	PTFE+Carbone PTFE+Carbon	
		Notre / Our Reference	Notre / Our Reference	Notre / Our Reference	Notre / Our Reference	Notre / Our Reference
8 - 12	15	POCH-PS410	POCH-PZ410	POCH-PP410	POCH-PY410	POCH-YN4010
15	20	POCH-PS415	POCH-PZ415	POCH-PP415	POCH-PY415	POCH-YN4015
20	25	POCH-PS420	POCH-PZ420	POCH-PP420	POCH-PY420	POCH-YN4020
25	32	POCH-PS425	POCH-PZ425	POCH-PP425	POCH-PY425	POCH-YN4025
32	40	POCH-PS432	POCH-PZ432	POCH-PP432	POCH-PY432	POCH-YN4032
40	50	POCH-PS440	POCH-PZ440	POCH-PP440	POCH-PY440	POCH-YN4040
50	65	POCH-PS450	POCH-PZ450	POCH-PP450	POCH-PY450	POCH-YN4050
65	80	POCH-PS4065	POCH-PZ4065	POCH-PP4065	POCH-PY465	POCH-YN4065
80	100	POCH-PS4080	POCH-PZ4080	POCH-PP4080	POCH-PY480	POCH-YN4080
100	125	POCH-PS4100	POCH-PZ4100	POCH-PP4100	POCH-PY4100	POCH-YN4100
125	150	POCH-PS4125	POCH-PZ4125	POCH-PP4125		
150	200	POCH-PS4150	POCH-PZ4150	POCH-PP4150		

Sphère inox 1.4409

316L stainless steel ball

DN Intégral <i>Full bore</i>	DN Standard <i>Reduce bore</i>	Notre / Our Reference
8 - 12	15	041009 P4NI
15	20	401509 2PNI
20	25	402009 2PNI
25	32	402509 2PNI
32	40	403209 2PNI
40	50	404009 2PNI
50	65	405009 2PNI
65	80	406509 2PNI
80	100	408009 2PNI
100	125	410009 2PNI
125	150	412509 2PNI
150	200	415009 2PNI

Tige de manœuvre inox 1.4404

316L stainless steel stem

DN Intégral <i>Full bore</i>	DN Standard <i>Reduce bore</i>	Notre / Our Reference
8 - 12	15	041005 P4NI
15	20	041505 P4NI
20	25	042005 P4NI
25	32	042005 P4NI
32	40	043205 P4NI
40	50	043205 P4NI
50	65	045005 P4NI
65	80	406505 2PNI
80	100	406505 2PNI
100	125	410005 2PNI
125	150	412505 2PNI
150	200	412505 2PNI

Sphère inox 1.4409

316L stainless steel ball

DN Intégral <i>Full bore</i>	Robinet inox <i>S.S. ball valve</i>
15	401509 2PNI
20	402009 2PNI
25	402509 2PNI
32	403209 2PNI
40	404009 2PNI
50	405009 2PNI
65	406509 2PNI
80	408009 2PNI
100	410009 2PNI
150	415009 2PNI
200	420009 2PNI

Tige de manœuvre 1.4404

316L stainless steel stem

DN Intégral <i>Full bore</i>	Notre / Our Reference
15	041505 P4NI
20	042005 P4NI
25	042005 P4NI
32	043205 P4NI
40	043205 P4NI
50	445005 2PNI
65	406505 2PNI
80	406505 2PNI
100	410005 2PNI
150	412505 2PNI
200	420005 2PNI

PIECES DE RECHANGE
SPARE PARTS LIST

Pochettes de joints

Comprenant :
2 sièges
1 joint de corps
1 garniture de presse étoupe
1 rondelle de friction

Spare seats kits

Including:
2 seats
1 body seal
1 gland packing
1 stem thrust seal

DN Standard <i>Reduced bore</i>	R2S	R2Z	R2H
	TFM 1600	PTFE +20%PEEK +20%PEEK PTFE	TFM 1600
	Notre / Our Reference	Notre / Our Reference	Notre / Our Reference
15	POCH-R2S015-P1	POCH-R2Z015-P1	POCH-R2H015-P9
20	POCH-R2S020-P1	POCH-R2Z020-P1	POCH-R2H020-P9
25	POCH-R2S025-P1	POCH-R2Z025-P1	POCH-R2H025-P9
32	POCH-R2S032-P1	POCH-R2Z032-P1	POCH-R2H032-P9
40	POCH-R2S040-P1	POCH-R2Z040-P1	POCH-R2H040-P9
50	POCH-R2S050-P1	POCH-R2Z050-P1	POCH-R2H050-P9
65	POCH-R2S065-P0	POCH-R2Z065-P0	POCH-R2H065-P9
80	POCH-R2S080-P0	POCH-R2Z080-P0	POCH-R2H080-P9
100	POCH-R2S100-P0	POCH-R2Z100-P0	POCH-R2H100-P9
150	POCH-R2S150-P0	POCH-R2Z150-P0	POCH-R2H150-P9
200	POCH-R2S200-P0	POCH-R2Z200-P0	POCH-R2H200-P9





MECA-INOX

1, rue de la Croix des Maheux
F-95031 CERGY-PONTOISE CEDEX
T. +33 1 78 47 80 00
infos@meca-inox.com

meca-inox.com